

DORIAN
INTERNATIONAL
TOOL

The First Choice
TECHNOLOGY

Solution Tool!™

No! Vibration Tunable Boring Bars
& High Performance Carbide Boring Bars



Solution Tool!™

Makes Deep Hole Boring Simple!

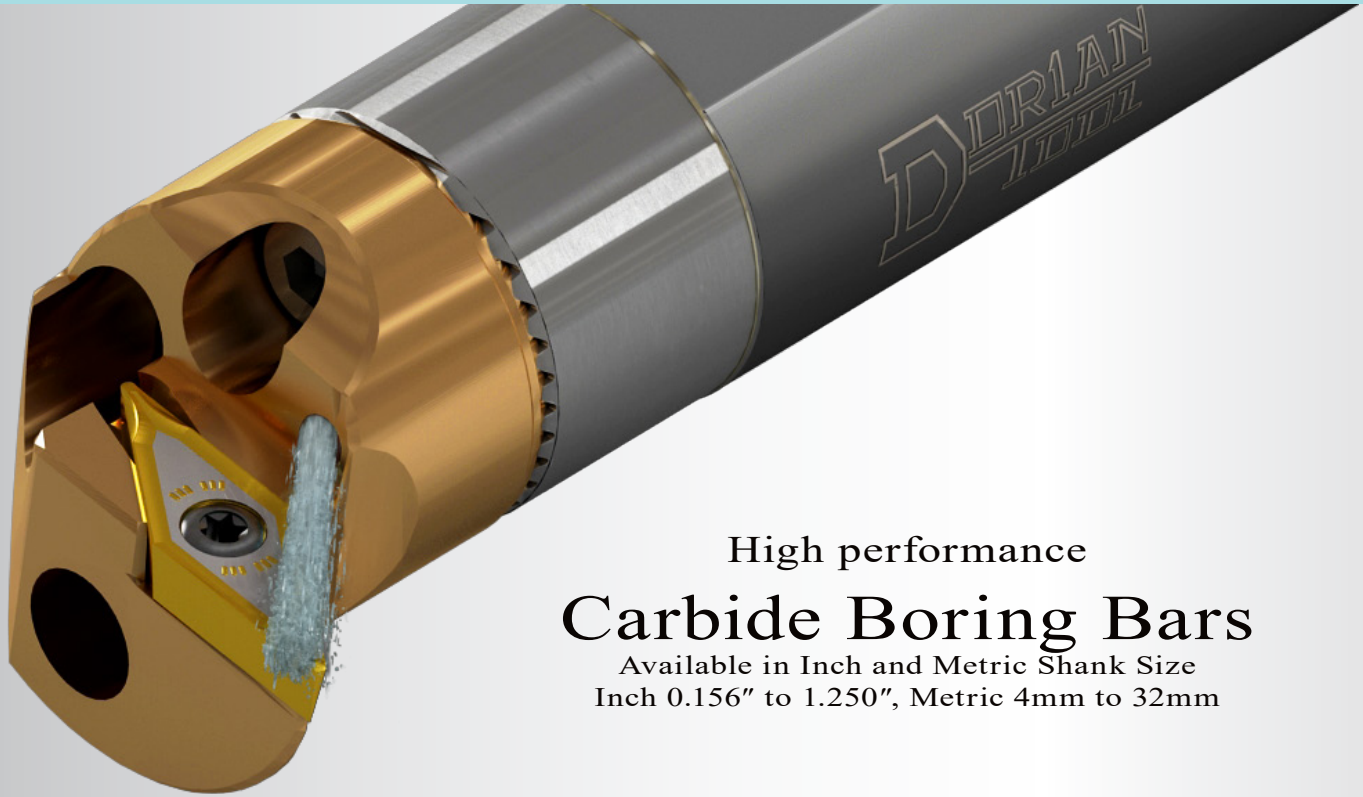

High performance Carbide Boring Bars

Available in Inch and Metric Shank Size
Inch 0.156" to 1.250", Metric 4mm to 32mm

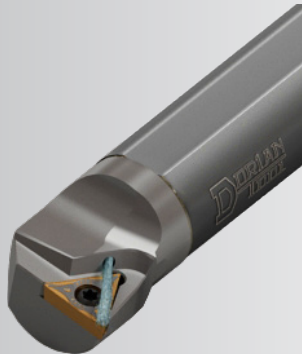

Thru Coolant Integral Carbide Boring System
Shank Size 0.156" to 1.250"
& (4mm to 32mm)

Page D-17 - D-29



Thru Coolant Integral Jet-Stream™ Carbide Boring System
Shank Size 1.000" to 1.250"
& (25mm to 32mm)

Page D-34 - D-36

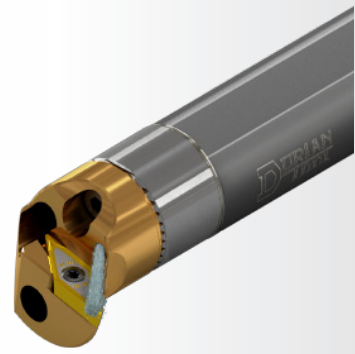

Quick Change Modular Carbide Boring System
Shank Size 0.750" to 1.250"
& (20mm to 32mm)

Page D-39 - D-45

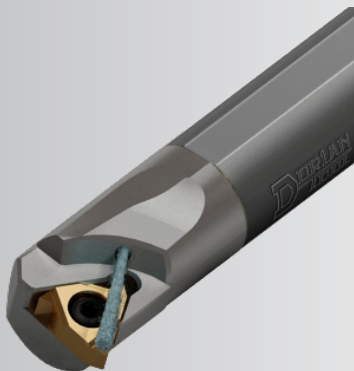

Thru Coolant Integral Carbide Threading System
Shank Size 0.218" to 0.750"
& (6mm to 20mm)

Page D-30 - D-31



Thru Coolant Integral Jet-Stream™ Carbide Threading System
Shank Size 0.750" to 1.250"
& (20mm to 32mm)

Page D-37 - D-38

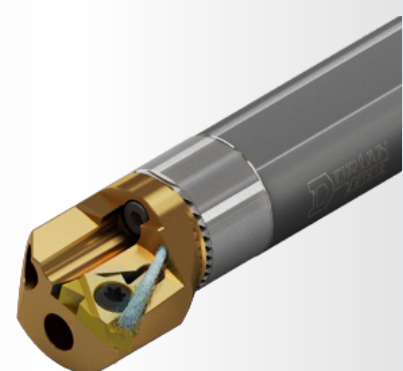

Quick Change Modular Carbide Threading System
Shank Size 0.750" to 1.250"
& (20mm to 32mm)

Page D-46



Solution Tool!™
**The NO! Vibration Tunable
 Boring Bars**

Available in Inch and Metric Shank Size
 Inch 0.25" to 4.00", Metric 6mm to 100mm

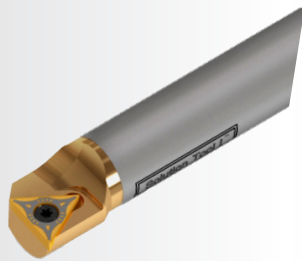

Solution Tool!™ Integral
 The NO! Vibration Tunable Boring System
 Shank Size 0.25 to 0.625"
 & (6mm to 16mm)

Page D-52 - D-67



Solution Tool!™ Quick Change Modular
 The NO! Vibration Tunable Boring System
 Shank Size 0.750" to 1.250"
 & (20mm to 32mm)

Page D-70 - D-77



Solution Tool!™ Modular Jet-Stream™
 The NO! Vibration Tunable Boring System
 Shank Size 1.500" to 4.00"
 & (40mm to 100mm)

Page D-81 - D-91

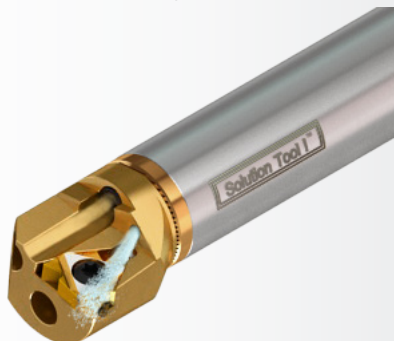

Solution Tool!™ Quick Change Modular
 The NO! Vibration Tunable Threading System
 Shank Size 0.750" to 1.250"
 & (20mm to 32mm)

Page D-78



Solution Tool!™ Modular Jet-Stream™
 The NO! Vibration Tunable Threading System
 Shank Size 1.500" to 4.00"
 & (32mm to 100mm)

Page D-91 - D-92

Technical Support for Deep Hole Boring

Solution Tool!™ The NO! Vibration Tunable Bars & High Performance Carbide Bars

For Multi Boring & Threading Operations

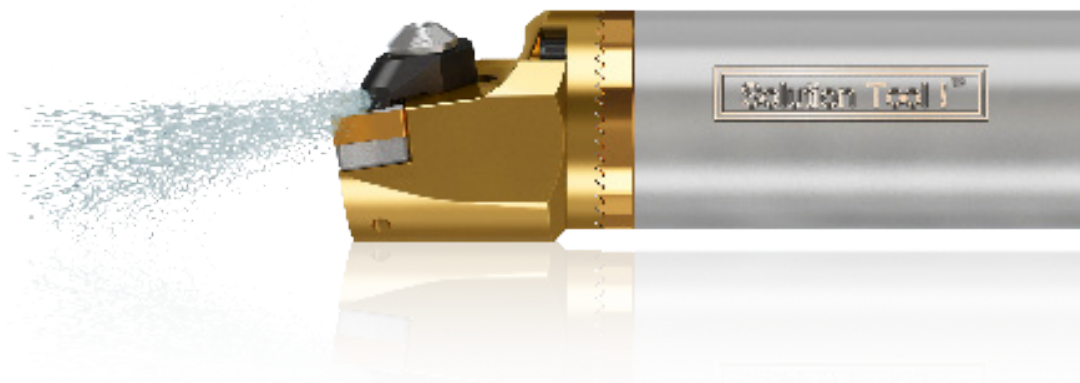

Technical Support

Deep Hole Boring Application Form	Page D-5
Deep Hole Boring Operation	Page D-6 - D-7
Deep Hole Boring Solutions	Page D-8 - D-14, D-48

Carbide Boring & Threading Bar Technology

Integral Thru Coolant Carbide Boring Bar System	6 x Dia. Boring Ratio	Page D-15 - D-29
Integral Thru Coolant Carbide Threading Bar System	6 x Dia. Threading Ratio	Page D-30 - D-31
Integral Jet-Stream™ Thru Coolant Carbide Boring Bar System	6 x Dia. Boring Ratio	Page D-33 - D-36
Integral Jet-Stream™ Thru Coolant Carbide Threading Bar System	6 x Dia. Threading Ratio	Page D-37 - D-38
Quick Change Modular Carbide Boring & Threading Bar System	6 x Dia. Boring Ratio	Page D-39 - D-46

Solution Tool!™ The NO! Vibration Tunable Boring & Threading Bars

Solution Tool!™ Integral The NO! Vibration Tunable Boring System	8 x Dia., 10 x Dia., 12 x Dia., 14 x Dia. Boring Ratio	Page D-49 - D-67
Solution Tool!™ Quick Change The NO! Vibration Tunable Boring & Threading Bar System	8 x Dia., 10 x Dia., 12 x Dia., 14 x Dia. Boring Ratio	Page D-68 - D-79
Solution Tool!™ Modular Jet-Stream™ The NO! Vibration Tunable Boring & Threading Bar System	8 x Dia., 10 x Dia., 12 x Dia., 14 x Dia. Boring Ratio	Page D-80 - D-92

High Pressure Coolant System Spare Parts

High Pressure Coolant System Spare Parts	Page D-93
--	-----------

Technical Support for Deep Hole Boring

Deep Hole Boring Application Form for Carbide & Solution Tool!™ Boring Bars

When selecting a cutting tool & insert you must check the appropriate boxes below and fax to 979-282-2951 or e-mail: sales@doriantool.com

Select Your Deep Hole Boring Operation:

1. Boring		4. Back Face	
2. Under-Cut		5. Grooving	
3. Profiling		6. Threading	

Company Name:	Contact Name:
Phone No: ()	E-mail:

Select Your Material:

P	Carbon & Alloy Steel
M	Stainless Steel
K	Cast Iron
N	Al. and non Ferrous Materials
S	High Temp Super Alloy
H	Hardened Material

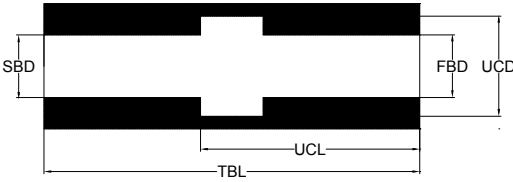
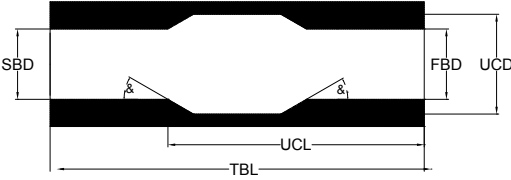
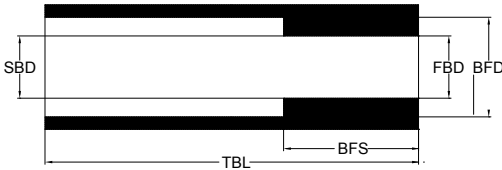
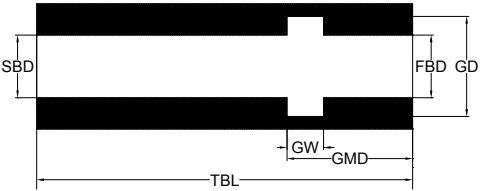
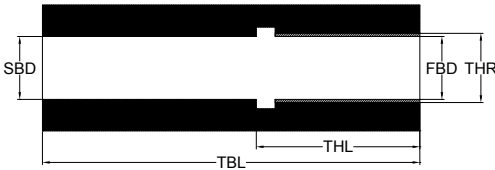
Operation	Boring Specification	Boring Description	Inch	Metric
1. Straight		SBD	Starting Bore Diameter	
		FBD	Finished Bore Diameter	
		TBL	Total Bore Length	
		Recommended Boring Bars and Tools		UPC 733101-
		Boring Bar		
		Boring Bar Head		
		Insert		
2. Under-Cut		SBD	Starting Bore Diameter	
		FBD	Finished Bore Diameter	
		TBL	Total Bore Length	
		UCD	Under-Cut Diameter	
		UCL	Under-Cut Distance	
		Recommended Boring Bars and Tools		UPC 733101-
		Boring Bar		
		Boring Bar Head		
		Insert		
3. Profiling		SBD	Starting Bore Diameter	
		FBD	Finished Bore Diameter	
		TBL	Total Bore Length	
		UCD	Under-Cut Diameter	
		UCL	Under-Cut Distance	
		&°	Angle Profile	
		Recommended Boring Bars and Tools		UPC 733101-
		Boring Bar		
		Boring Bar Head		
		Insert		
4. Back Face		SBD	Starting Bore Diameter	
		FBD	Finished Bore Diameter	
		TBL	Total Bore Length	
		BFD	Back Face Diameter	
		BFS	Back Face Shoulder	
		Recommended Boring Bars and Tools		UPC 733101-
		Boring Bar		
		Boring Bar Head		
		Insert		
5. Grooving		SBD	Starting Bore Diameter	
		FBD	Finished Bore Diameter	
		TBL	Total Bore Length	
		GD	Groove Diameter	
		GW	Groove Width	
		GMD	Groove Max. distance	
		Recommended Boring Bars and Tools		UPC 733101-
		Boring Bar		
		Boring Bar Head		
		Insert		
6. Threading		SBD	Starting Bore Diameter	
		FBD	Finished Bore Diameter	
		TBL	Total Bore Length	
		THR	Thread Dimension	
		THL	Thread Length	
		Recommended Boring Bars and Tools		UPC 733101-
		Boring Bar		
		Boring Bar Head		
		Insert		

Technical Support for Deep Hole Boring

Deep Hole Boring Operation

1. Workholding

Use the proper chuck and jaws to hold the work-piece, to assure that the part is held with maximum rigidity and stability under cutting force.

2. Steady Rest

When boring a long part, it is necessary to have extra support from the steady rest to eliminate any deflection of the part under the cutting force that causes vibration and poor surface finish.

3. Boring Bar Size

Choose a boring bar with the largest diameter to clear the bore, maximizing rigidity. Make sure to provide enough clearance between the bore and the bar for chip evacuation so damaging does not occur on the bore wall. Also choose the shortest overhang to reduce vibration.

4. Boring Bar Holding

For best results, hold the bar 4 x Dia. & choose a split collar boring bar holder. The 360° locking system offers the largest surface contact between the boring bar and the holder, maximizing bar rigidity and minimizing vibration.

5. Coolant System

It is very important that the bore is kept clean and free of chips while cutting to avoid surface damage and insert to breakage. Use high pressure coolant with the boring bar to flush the chips out while cutting.

6. Insert

To avoid and reduce vibration of the bar, that causes chattering. Use the insert with the as small of an angle geometry possible, small nose radius, high positive rake angle and sharp cutting edge.

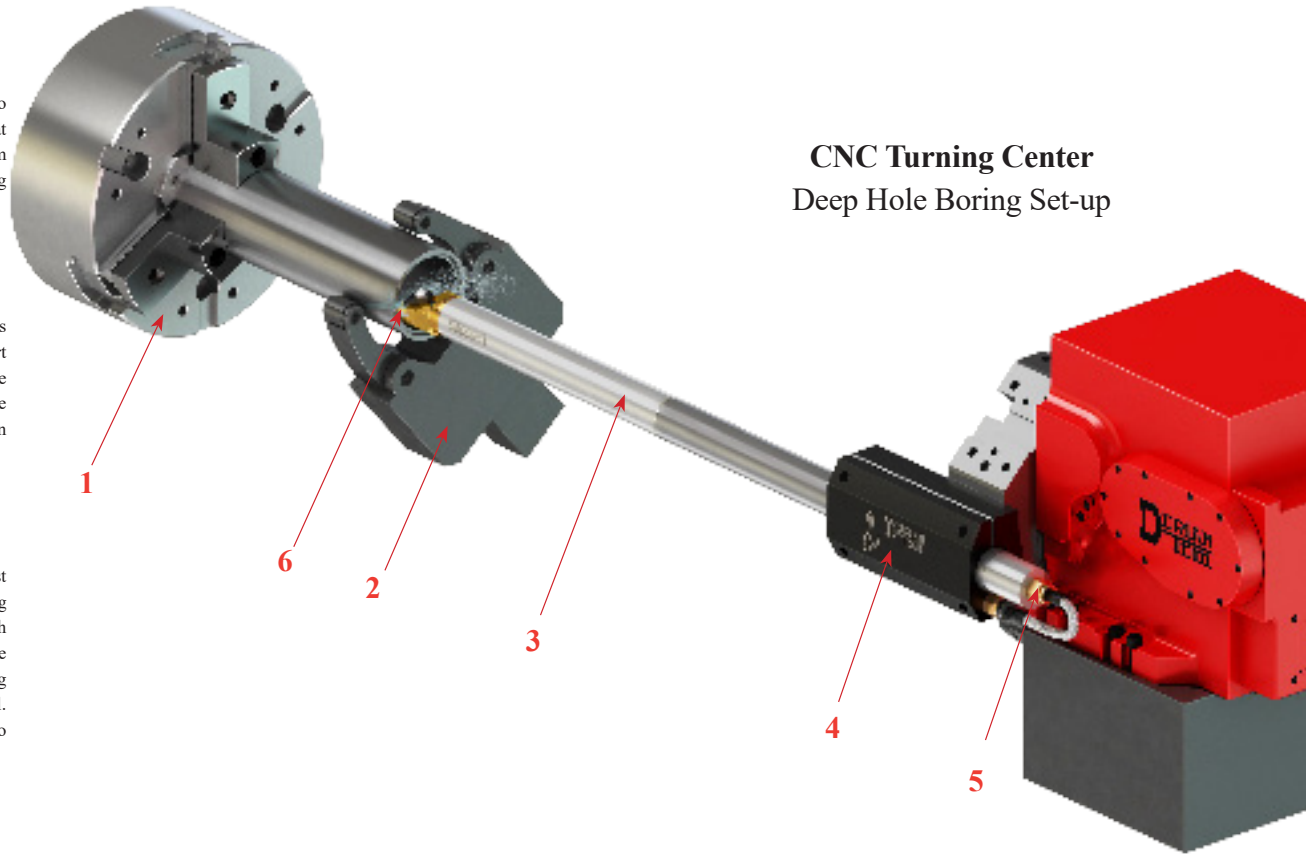

CNC Turning Center
Deep Hole Boring Set-up

*To Achieve Optimum Results for Deep Hole Boring
It is extremely important to follow steps 1-6.*

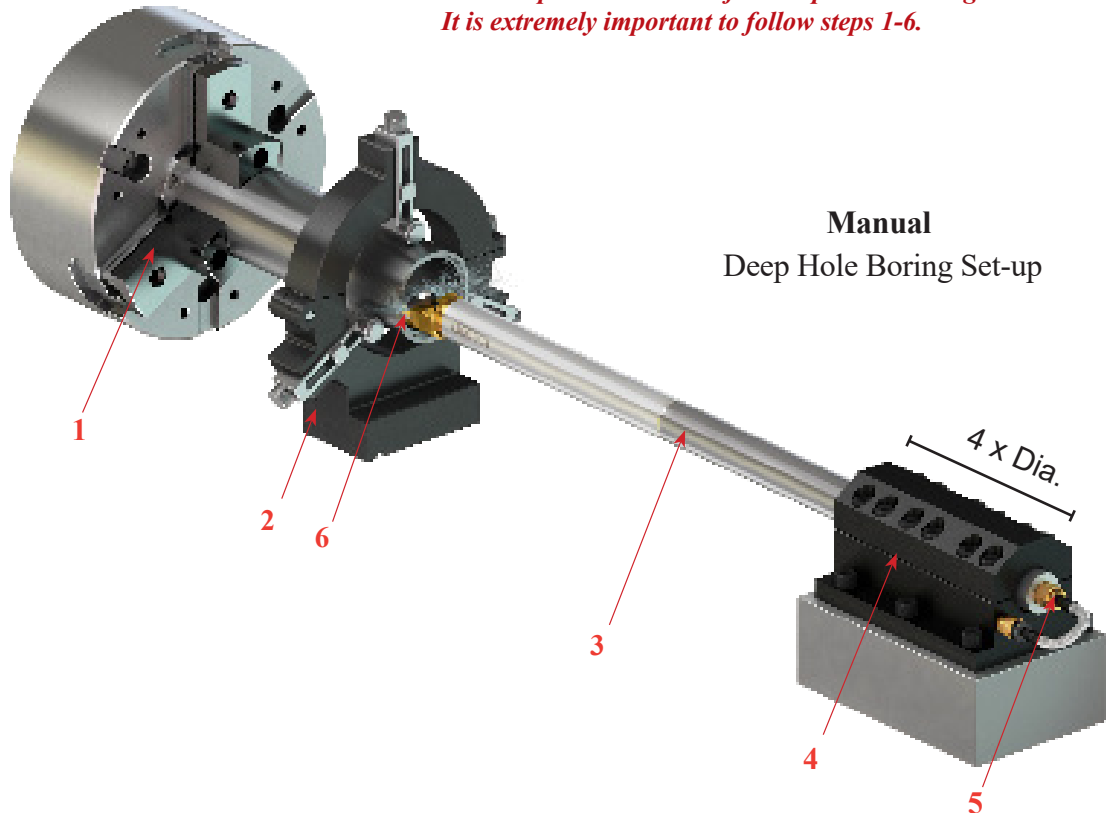

Manual
Deep Hole Boring Set-up

Deep Hole Boring Operation

IN A DEEP HOLE BORING OPERATION:

- The diameter size of the boring bar is limited from the size of the hole diameter to be bored.
- The boring bar should have the largest diameter possible for maximum cutting rigidity, but small enough to clear the hole for chip evacuation.
- The Boring Bar has to be held with the maximum rigidity and the shortest overhang possible to maximize cutting stability and minimize vibration.
- The selection and use of the right insert grade, geometry, nose radius and rake angle will be critical for a good surface finish and close working tolerance.
- The cutting parameter is to be correct for the material machined in accordance of the insert manufacturing cutting data.
- The hole, while machined has to be kept clear from chips to avoid tool breakage, boring bar vibration and the walls of the work piece undamaged.



THE COMMON DEEP HOLE BORING OPERATION PROBLEMS:

Poor Surface Finish, Poor Machining Tolerance & Poor Insert Life

THE COMMON CAUSE:

1) Boring Bar Cutting Ratio:

If the incorrect boring bar cutting ratio is used, the boring bar will not perform.

2) Boring Bar Holding System:

When boring bar is not held properly and rigid on to the boring bar holder, vibration will develop when cutting.

3) Boring Bar Diameter:

To small boring bar diameter will deflect under pressure and vibrate, to large boring bar diameter, will obstruct the evacuation of the chips.

4) Boring Overhang:

The boring bar is over extended (Steel 4 x Dia., Carbide 6 x Dia., Solution Tool!™ (The NO! Vibration Tunable Boring Bar) 8 x Dia., and over).

5) Incorrect Insert:

Incorrect insert grade geometry for the boring operation with incorrect nose radius, rake angle, chip break, and clearance angle.

6) Cutting Parameter:

Wrong cutting parameters are used for the specific work piece material to be cut, and for the operation to be executed.

7) Chip Clogging:

Chips are clogged in to the work piece bore jamming the insert, wrapping around the boring bar, and thrown against the wall.

Technical Support for Deep Hole Boring

1) Bar Cutting Ratio Deep Hole Boring Solution:

Problem

Boring Bar Cutting Ratio: If the incorrect boring bar cutting ratio is used, the boring bar will not perform.

Solution: Choose the correct boring bar cutting Ratio for optimum performance

Boring Depth: The depth of the machining bore determines on the style and the type material of the boring bar.

The general rule for boring bar depth is steel bar boring have a short depth, carbide bars have a medium depth, and anti vibration tunable boring bars have a long depth.

The Max. Boring Bar Overhangs: The maximum extended length of the boring bar before loss of rigidity and the start of vibration with poor cutting performance.

Boring Bar Overhangs: Is the distance measured from the face of the Boring Bar Holder to the Insert Cutting Edge,

Boring Bar Cutting Ratio: Maximum cutting length of the boring bar in relation to its own body diameter.

Ex.: 1" (25mm) Boring Bar with 10 x Dia. Ratio, Maximum cutting length is 10" (250mm)

Threading Bar Cutting Ratio: When threading the radial force is higher than boring, the threading Ratio is reduced considerably over boring.

If the incorrect boring bar cutting ratio is used, the boring bar will not perform.

Maximum Boring & Threading Ratio According to Steel or Carbide Bar Material

Steel Bar

4 x Dia. Boring Ratio
2 x Dia. Threading Ratio

- General boring bar applications
- Roughing to finishing
- Stable for high material removal
- Poor for small bores

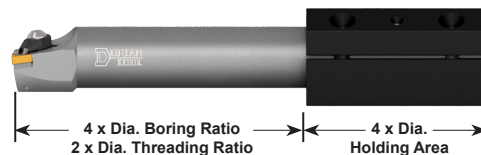

Carbide Bar

6 x Dia. Boring Ratio
3 x Dia. Threading Ratio

- Best for boring small holes
- Rigid for close tolerance and furnace finish
- Rigid for heavy material removal at high ap and fn

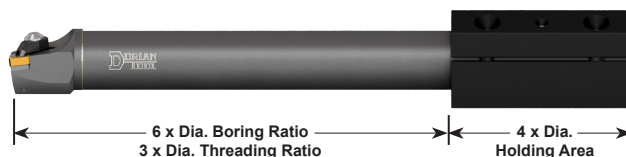

Steel Body (Solution Tool!™)

8 x Dia., 10 x Dia., 12 x Dia. Boring Ratio
4 x Dia. Threading Ratio

- For deep hole boring applications

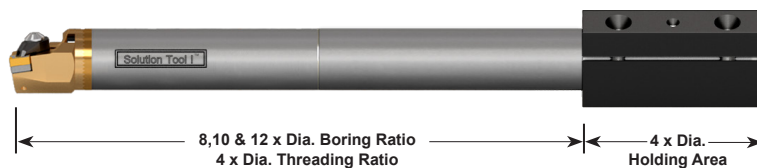

Carbide Body (Solution Tool!™)

8 x Dia., 10 x Dia., 12 x Dia., 14 x Dia. Boring Ratio
5 x Dia. Threading Ratio

- For high performance deep hole boring applications

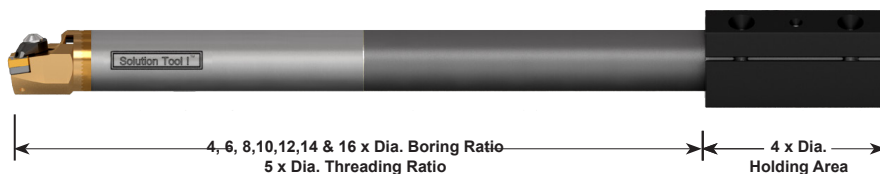

2) Bar Holding System Deep Hole Boring Solution:

Problem

Boring Bar Holding System: When boring bar is not held properly and rigid on to the boring bar holder, vibration will develop when cutting with poor surface finish, tolerance, and insert life.

Solution: When holding the boring bar, the boring bar holder must:

1. Have a Precise and smooth bore
2. Use the most rigid holding system of the boring bar
3. Have a holding length of the boring bar at 4 x boring bar diameter

BEST Split Collar Holding System Boring Bar Holding System

Locks the boring bar at 360° on the diameter, assuring the most rigidity and precise boring bar positioning *Without scarring or damaging the bar surface.*

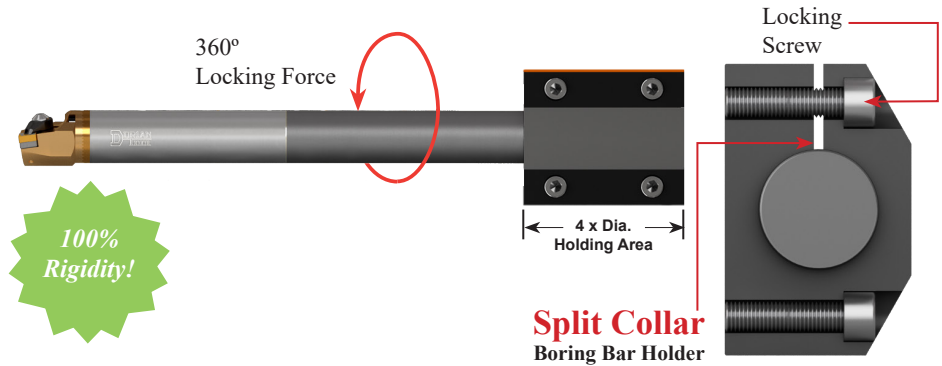

GOOD Split Bushing Holding System With a solid boring bar holder

The split bushing embraces the boring bar at 360° on the diameter. The screw will squeeze the bushing around the boring bar *Without scarring or damaging the bar surface with precise positioning.*

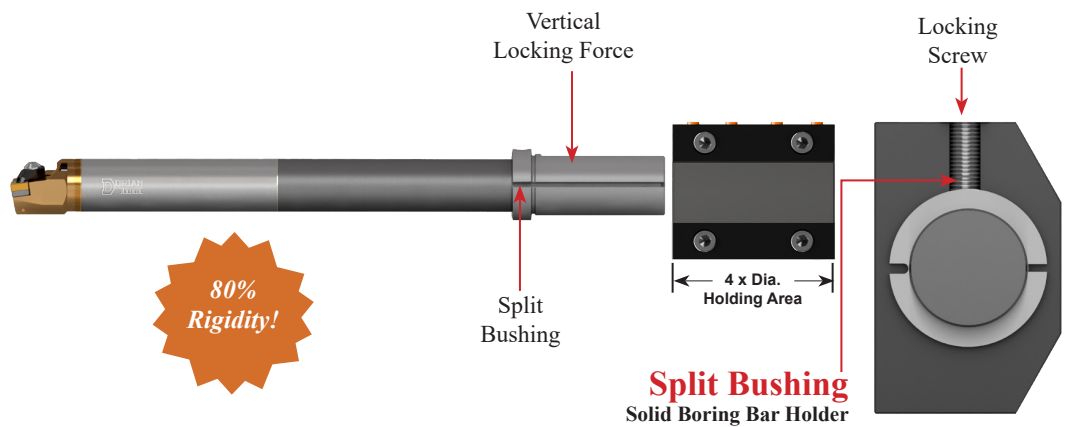

STOP Do Not Use It Set Screw Lock Holding System Solid boring bar holder Without bushing

Never lock the screw over the boring bar. Locking a screw over the boring bar will create only one point of contact causing very poor rigidity. Additionally, the *screw will damage the boring bar surface and make positioning difficult.*

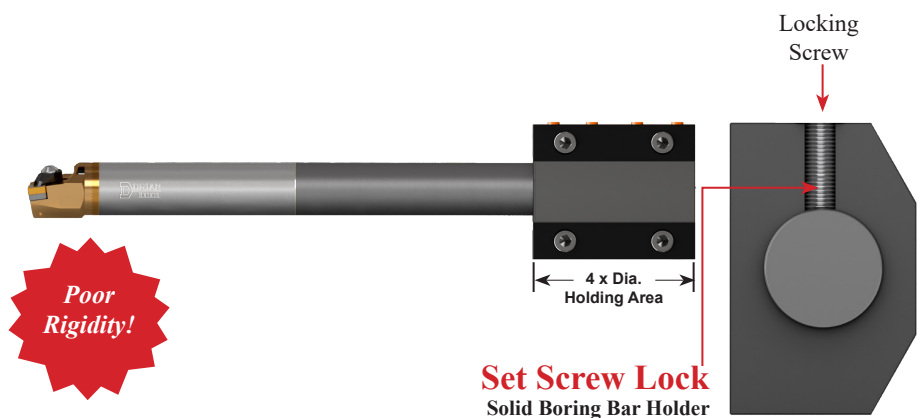

Technical Support for Deep Hole Boring

3) Bar Diameter Deep Hole Boring Solution:

Problem

Boring Bar Diameter: Too small boring bar diameter will deflect under pressure and vibrate, Too large boring bar diameter, will obstruct the evacuation of the chips

Solution: Use the largest boring bar for rigidity and performance, but small enough for the chips to evacuate

Small Boring Bar Diameter: If the diameter of the boring is too small, it has no rigidity to withstand the tangential and radial forces that generate under the cutting pressure. The bar will be easily pushed down below the center line, and deflect away from the cutting wall. When this occurs, the boring bar is not any more in control of the boring operation to a point that the boring bar will vibrate with poor surface finish, poor machining tolerance, and short insert life.

Use the largest boring bar possible that clears the bore diameter and allows chips evacuation

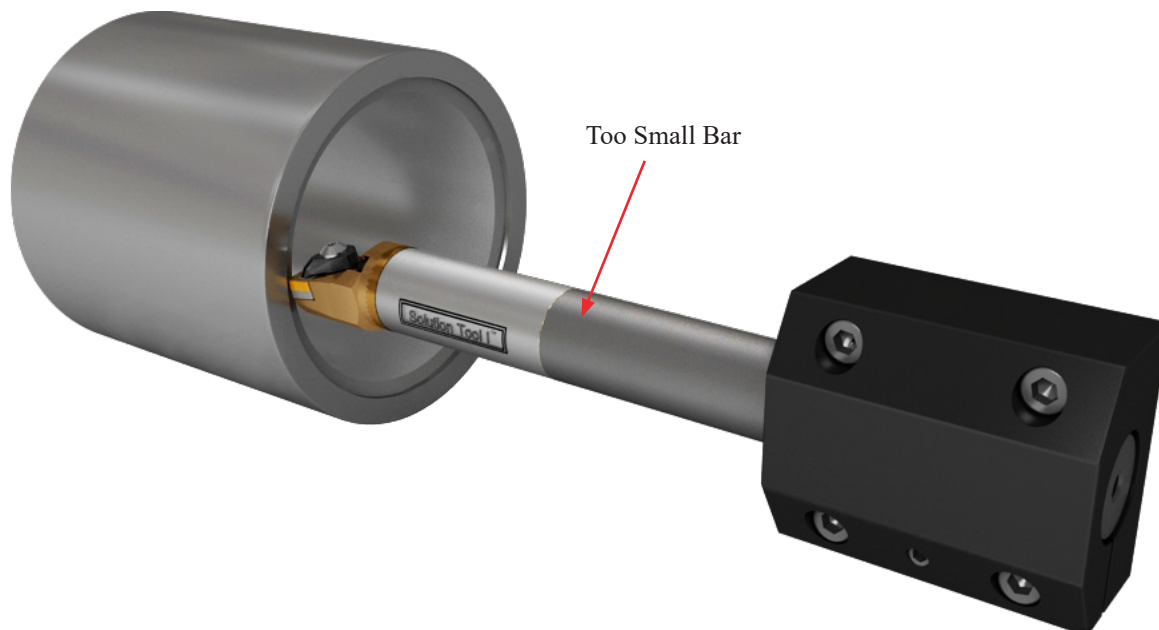

Large Boring Bar Diameter: If the diameter of the boring is too large, there will be no clearance between the bore diameter and the boring bar body, making impossible for the chips to evacuate. The chips will be jammed against the wall of the hole and the boring bar, damaging the work piece wall destroying the insert.

Use a smaller boring bar Without losing rigidity and to allow the chips to evacuate.

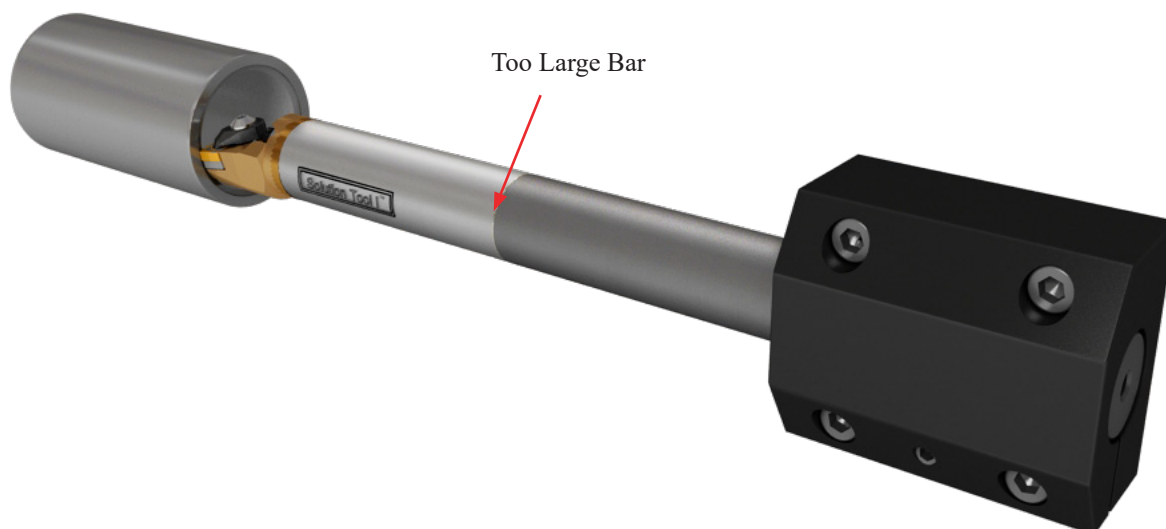

4) Bar Overhang and Deflection Deep Hole Boring Solution:

Problem

Boring Overhang: The boring bar is over extended, exceeding the overhang limit built for.

Boring Bar Deflection: The bar under the Cutting Pressure will deflect.

Overhang Solution: Use and set the boring bar to the correct overhang that is built for; Steel Boring bar 4 x Dia., Carbide 6 x Dia., Solution Tool!™ NO! Vibration Tunable Boring Bar Steel Body 8 x Dia., 10 x Dia., Carbide 12 x Dia., and 14 x Dia..

Deflection Solution: Place the insert cutting edge above the center line. 10% diameter of bar.

Example: 1" inch bar 1% = .010

25 mm bar 1% = .25

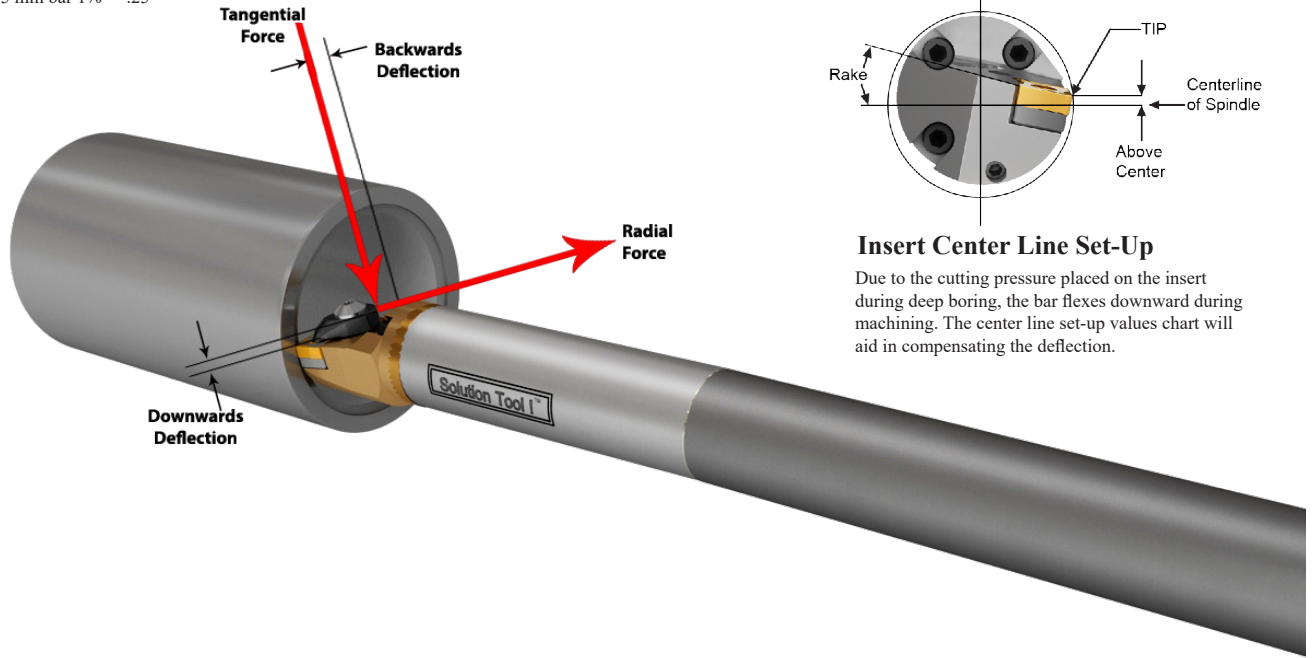

Insert Center Line Set-Up

Due to the cutting pressure placed on the insert during deep boring, the bar flexes downward during machining. The center line set-up values chart will aid in compensating the deflection.

In the Boring Operation, the Boring Bar is to Withstand all the stress derived from the cutting force. In a long depth of cut, the stress is multiplied with a long overhang of the boring bar.

The boring bar becomes unstable and very flexible under the cutting force.

When the Boring Bar is cutting, the Tangential and the Radial cutting force applied over the cutting edge of the insert will push the Boring Bar below the center line and away from the cutting wall. The Tangential Force generate under the cutting operation will increase with the depth of cut and feed rate in pushing the insert below the center line.

The insert clearance angle will be reduce, and the body of the insert will make contact with the cutting wall creating interference and friction with poor cutting results.

The Radial Force will push the insert away from the cutting surface creating an harmonic or weaving reaction.

The insert cutting edge, will be moving in and out from the cutting wall surface. The deflection of the boring bar is direct related to the overhang of the boring bar and the depth of cut and feed rate.

Use the shortest overhang boring bar possible to minimize deflection and maximize cutting performance.

Solution Tool!™ Center line Set-up Values Chart (Inch)

Bar Size Dia. (in.)	Nominal Center (in.)	Insert Set-Up Above Center Line*			Depth of Cut	
		Finish	Rough	Rough/Finish	Finishing	Roughing
0.500	0.250	.005	.010	.0075	.001"	.020"
0.625	0.3125	.006	.012	.009	.001"	.030"
0.750	0.3750	.007	.014	.021	.001"	.050"
1.000	0.500	.010	.020	.015	.001"	.070"
1.250	0.625	.012	.024	.018	.001"	.075"
1.500	0.750	.015	.030	.0225	.002"	.080"
1.750	0.8750	.0175	.035	.026	.002"	.085"
2.000	1.000	.020	.040	.030	.002"	.090"
2.500	1.250	.025	.050	.0375	.002"	.095"
3.000	1.500	.030	.060	.045	.003"	.100"
4.000	2.000	.040	.080	.060	.003"	.120"

The above values can change depending on different aspects of machining.

For example a sharper insert will deflect less. Use table as reference only, as actual values may need to be adjusted as necessary.

Solution Tool!™ Center line Set-up Values Chart (Metric)

Bar Size Dia. (mm)	Nominal Center (mm)	Insert Set-Up Above Center Line*			Depth of Cut	
		Finish	Rough	Rough/Finish	Finishing	Roughing
12	6	.2	.4	.3	.025	.50
16	8	.25	.5	.375	.025	.75
20	10	.3	.6	.45	.025	1.2
25	12.5	.35	.7	.5	.025	1.7
32	16	.4	.8	.6	.025	1.8
40	20	.45	.9	.7	.050	2.0
N/A	N/A	N/A	N/A	N/A	N/A	N/A
50	25	.5	1.0	.75	.050	2.1
60	30	.6	1.2	.9	.050	2.3
80	40	.8	1.6	1.2	.075	2.5
100	50	1.0	2.0	1.5	.075	3.0

Technical Support for Deep Hole Boring

5) Incorrect Insert Deep Hole Boring Solution:

Problem

Use of Incorrect Insert: Incorrect insert grade and geometry for material or operation excited and/or any other insert characteristics of the insert, such as nose radius, rake angle, chip break clearance angle, and cutting leading angle, can contribute to the cutting problems.

Solution: Use the correct insert grade, geometry and characteristics for the material to be machined and the operation to be executed.

For a **Finishing** operation and small depth of cut, use a wear resistant grade insert with a positive rake angle, small nose radius, sharp cutting edge, large chip break, and clearance angle. If the insert is too hard, it will chip and break under the cutting pressure, and vibration will develop. Switch to a softer grade.

For a **Roughing** operation and large depth of cut, use an impact resistant insert with a positive rake angle, medium to large nose radius, honed cutting edge, large chip break, and clearance angle. If the insert is too soft it will wear prematurely, and friction will develop losing tolerance and good surface finish, switch to a harder grade.

Minimum depth of cut is 1/2 of the insert radius. Maximum feed rate is 1/2 of the insert radius.

For a **Deep Boring** operation, always use a Solution Tool!™ boring bar with a high positive and sharp cutting edge insert.

Use the smallest insert angle geometry for the operation, like;

"V" for profiling and finishing

"D" for general application

"T" For light roughing and finishing

"C" For heavy roughing

Use the correct insert grade for the material and operation. Use a small angle geometry, like the "V", "D" and "T" style insert, small nose radius, sharp cutting edge, high positive rake angle, large chip breaker and high clearance angle.

INSERT VIBRATION

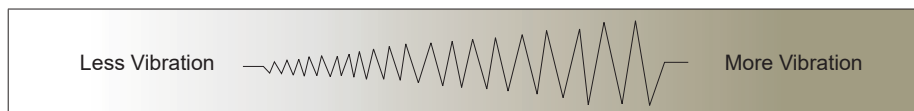

Small ap
Low fn & High RPM

Large ap
High fn & low RPM

INSERT GEOMETRY

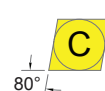
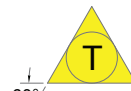
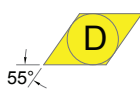
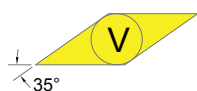

INSERT RADIUS

Use a smaller radius to limit vibration

.004 r.

.008 r.

1/64 r.

1/32 r.

INSERT CUTTING RAKE

Use a positive cutting rake to limit vibration.

High Positive

Positive

Neutral

Negative

INSERT RELIEF ANGLE

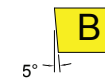
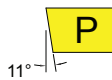

INSERT EDGE PREP



INSERT CUTTING EDGE ANGLE

Use a cutting edge angle as close to 90° as possible.

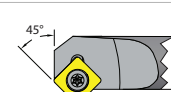
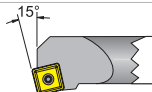
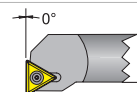
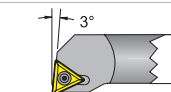

INSERT CENTER LINE

Insert Center Line, .002 to .025" [.050 to .635mm] above center line, to compensate for bar deflection and reduce vibration.

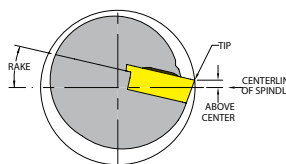

6) Cutting Parameter Deep Hole Boring Solution:

Problem

Cutting Parameter: If the cutting parameters are not correct for the specific material chattering and insert breakage will occur.

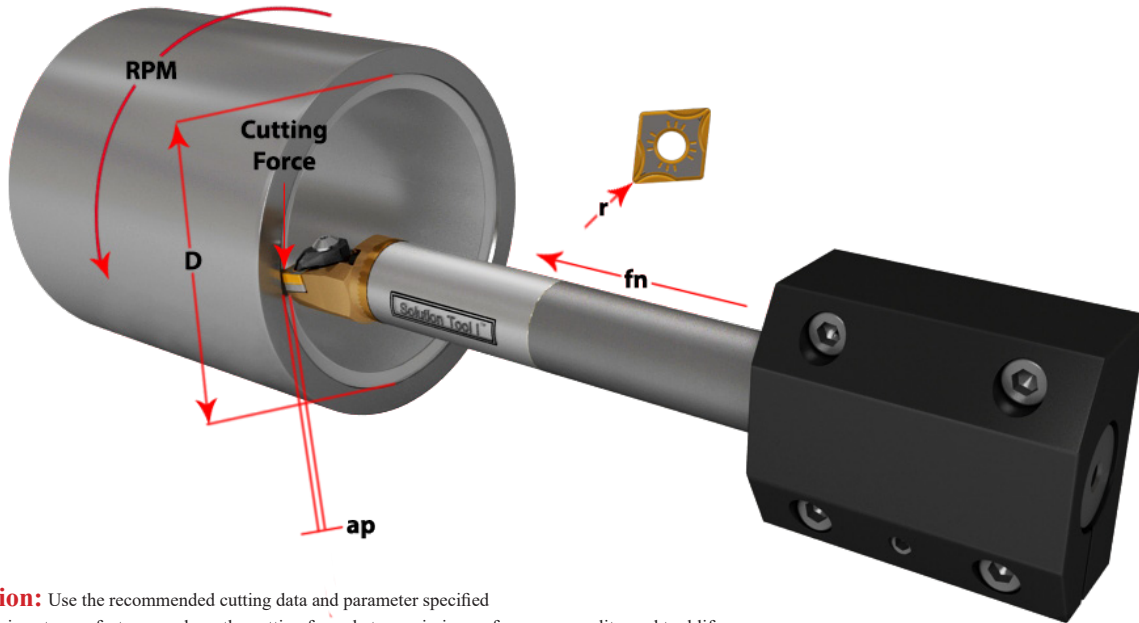

Solution: Use the recommended cutting data and parameter specified from the insert manufacturer, and use the cutting formula to maximize performance, quality, and tool life.

For a **Roughing** operation with a large depth of cut and a high feed rate, low RPM is recommended.

For a **Finishing** operation with a small depth of cut and a low feed rate, high RPM is recommended.

Minimum depth of cut is 1/2 of the insert radius. Maximum feed rate is 1/2 of the insert radius.

Inch Formulas for Turning and Boring

ap= Depth of cut (DOC)	Inch	kc= Specific cutting force	Lb/Inch ²
Dm= Diameter of part (DIA)	Inch	n= Spindle speed (RPM)	Rev/Min
fn= Feed per revolution (FEED)	Inch/Rev	vc= Cutting speed (SFM)	Feet/Min
lm= Machined length (LEN)	Inch	Tc= Cutting time (TIM)	Min
Q= Metal removal rate (MMR)	Inch ³ / Min	Rmax= Profile depth	μInch
Pc= Power requirements (POW)	Hp	rc= Insert nose radius	Inch
Cutting Speed Surface Feet Per Minute:	EX: Determine the cutting speed (vc) required for turning a 2-1/2" diameter part with a spindle speed of 600 RPM.		
$vc = \frac{\pi \times Dm \times n}{12}$	$vc = \frac{\pi \times 2.5 \times 600}{12} = 392.70 \text{ Feet/Min}$		
Spindle Speed Revolution Per Minute:	EX: Determine the spindle speed (n) required for turning a 2-1/2" diameter part with a cutting speed of 400 SFM.		
$n = \frac{Vc \times 12}{\pi \times Dm}$	$n = \frac{400 \times 12}{\pi \times 2.5} = 611.15 \text{ Rev/Min}$		
Metal Removal Rate Inch ³ /Min:	EX: Determine the metal removal rate (Q) required for cutting with a depth of .062 with a cutting speed of 400 SFM and feed rate of .015 IPR.		
$Q = vc \times ap \times fn \times 12$	$Q = 400 \times .062 \times .015 \times 12 = 4.464 \text{ inch}^3/\text{min}$		
Power Requirement Horsepower:	EX: Determine the power requirement (Pc) for turning a material with a cutting force of 181,750, a depth of .062, a cutting speed of 400 SFM, and feed rate of .015 IPR.		
$Pc = \frac{vc \times ap \times fn \times kc}{33,000}$	$Pc = \frac{400 \times .062 \times .015 \times 181,750}{33,000} = 2.05 \text{ HP}$		
Cutting Time Minute:	EX: Determine the amount of time required to machine a 6" long part with a spindle speed of 600 RPM and feed rate of .015 IPR.		
$Tc = \frac{lm}{fn \times n}$	$Tc = \frac{6}{.015 \times 600} = .67 \text{ Min (40 Sec)}$		
Profile Depth (μInch)	EX: Determine the profile depth (Rmax) of a surface machined using an insert with a nose radius of .032 and a feed rate of .015 IPR.		
$R_{max} = \frac{fn^2 \times 10^6}{8rc}$	$R_{max} = \frac{.015^2 \times 10^6}{8 \times .032} = 879 \mu\text{inch}$		

Metric Formulas for Turning and Boring

ap= Depth of cut (DOC)	mm	kc= Specific cutting force	Nm
Dm= Diameter of part (DIA)	mm	n= Spindle speed (RPM)	Rev/Min
fn= Feed per revolution (FEED)	mm/Rev	vc= Cutting speed (SFM)	m/Min
lm= Machined length (LEN)	mm	Tc= Cutting time (TIM)	Min
Q= Metal removal rate (MMR)	mm ³ / Min	Rmax= Profile depth	μm
Pc= Power requirements (POW)	kW	rc= Insert nose radius	mm
Cutting Speed Surface Meters Per Minute	EX: Determine the cutting speed (vc) required for turning a 50mm diameter part with a spindle speed of 600 RPM.		
$vc = \frac{\pi \times Dm \times n}{1000}$	$vc = \frac{\pi \times 50 \times 600}{1000} = 94.25 \text{ m/Min}$		
Spindle Speed Revolution Per Minute	EX: Determine the spindle speed (n) required for turning a 32mm diameter part with a cutting speed of 100 m/Min.		
$n = \frac{Vc \times 1000}{\pi \times Dm}$	$n = \frac{100 \times 1000}{\pi \times 32} = 994.72 \text{ Rev/Min}$		
Metal Removal Rate mm ³ /Min	EX: Determine the metal removal rate (Q) required for cutting with a depth of 1.5 with a cutting speed of 200 m/Min and feed rate of 0.4 mmPR.		
$Q = vc \times ap \times fn \times 1000$	$Q = 200 \times 1.5 \times 0.4 \times 1000 = 120.000 \text{ mm}^3/\text{min}$		
Power Requirement Kilowatts	EX: Determine the power requirement (Pc) for turning a material with a specific cutting force of 20,500, a depth of 1.5, a cutting speed of 200 m/Min, and feed rate of 0.4 mmPR.		
$Pc = \frac{vc \times ap \times fn \times kc}{1,460,000}$	$Pc = \frac{200 \times 1.5 \times 0.4 \times 20,500}{1,460,000} = 1.68 \text{ kW}$		
Cutting Time Minute	EX: Determine the amount of time required to machine a 200mm long part with a spindle speed of 600 RPM and feed rate of 0.4 mmPR.		
$Tc = \frac{lm}{fn \times n}$	$Tc = \frac{200}{0.4 \times 600} = .83 \text{ Min (50 Sec)}$		
Profile Depth (μm)	EX: Determine the profile depth (Rmax) of a surface machined using an insert with a nose radius of 0.8 and a feed rate of 0.4 mmPR.		
$R_{max} = \frac{fn^2 \times 10^6}{8rc}$	$R_{max} = \frac{.4^2 \times 10^6}{8 \times 0.8} = 25 \mu\text{m}$		

Technical Support for Deep Hole Boring

7) Chip Clogging Deep Hole Boring Solution:

Problem

Chip Clogging: Chips are clogged into the work piece bore jamming the insert, wrapping around the boring bar, and thrown against the wall.

Solution: Change the cutting length of the chips and use high pressure coolant or air to flush the chips out the bore.

Chip evacuation

Chip clogging during the boring operation creates a major machining problem effecting quality, performance and tooling life. Chips are to be removed from the bore as quickly as they are made to avoid and minimize the tooling insert damage, and poor surface finish. Evacuating chips from a bore is not always easy, and is more difficult when machining small diameters and deep bores. If the chips are very short and thick, a lot pressure is placed over the insert cutting edge making the boring bar vibrate. More tangential force is developed, requiring more horsepower (Kilowatts) for the boring operation.

In high speed rotation, the centrifugal force will push the chips against the wall surface making it difficult to remove out from the bore. It is more difficult when boring a small, blind, and deep hole. The chips will pack on the end of the bore.

If chips are long and stringy they are easy to machine.

Little tangential force is developed requiring less horsepower (Kilowatts) for the boring operation, but the chips will wrap around the boring bar and jam the inside of bore, or to the end of the blind hole making it impossible to evacuate from the bore. When this occurs the operation must be stopped, and the chips have to be manually removed from the bore.

To control the chips from clogging and to evacuate them easily from the bore, the chips are to be cut the right length. Not too short to minimize insert damage and cutting force, not too long to prevent them from wrapping around the boring bar.

The insert rake angle and chip break, depth of cut, feed rate, and RPM will control the length of the chips.

High Pressure Coolant and or Air will remove chips from the bore.

Use a Thru Coolant Boring Bar.

It is best if a Dorian Jet Stream Thru Coolant Boring Bar combined with high pressure coolant system is used. The coolant is aimed directly over the cutting edge of the insert at a high velocity blowing the chips away from the insert and flushing them out the bore.

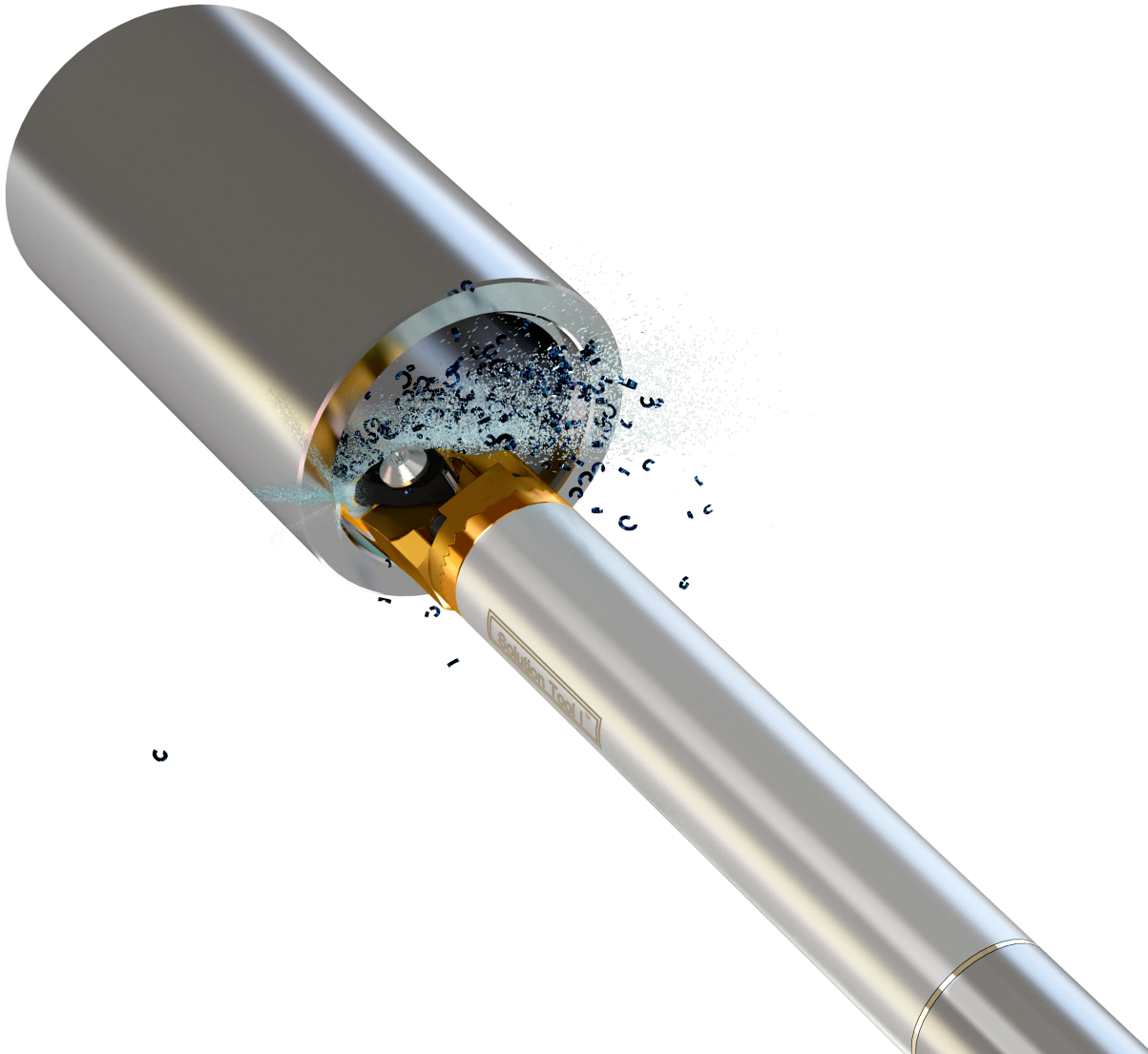

High Performance Carbide Bars

Thru Coolant Carbide Boring Bar

Best Application for:

- Boring and Threading
- Heavy Roughing and Finishing Operation
- Close working tolerances
- Boring Ratio 6 x Bar Dia.
- Threading Ratio 3 x Bar Dia.

High Performance Carbide Integral Thru Coolant Bars

- For small bores
- Carbide Body
- Boring System Shank Size
Inch 0.156" to 1.250"
Metric 4mm to 32mm
- Threading System Shank Size
Inch 0.218" to 0.750"
Metric 6mm to 20mm

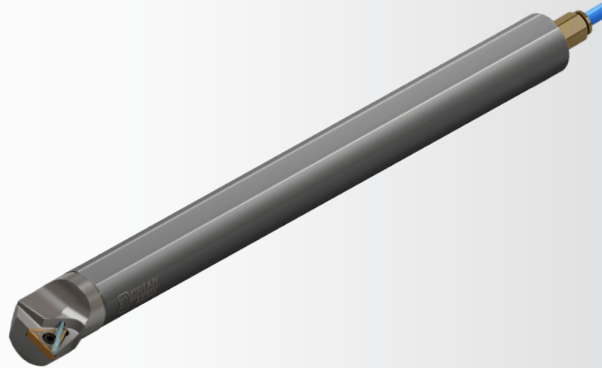

High Performance Carbide Integral Jet-Stream™ Thru Coolant Bars

- For medium bores
- Carbide Body
- Boring System Shank Size
Inch 1.000" to 1.250"
Metric 25mm to 32mm
- Threading System Shank Size
Inch 0.750" to 1.250"
Metric 20mm to 32mm

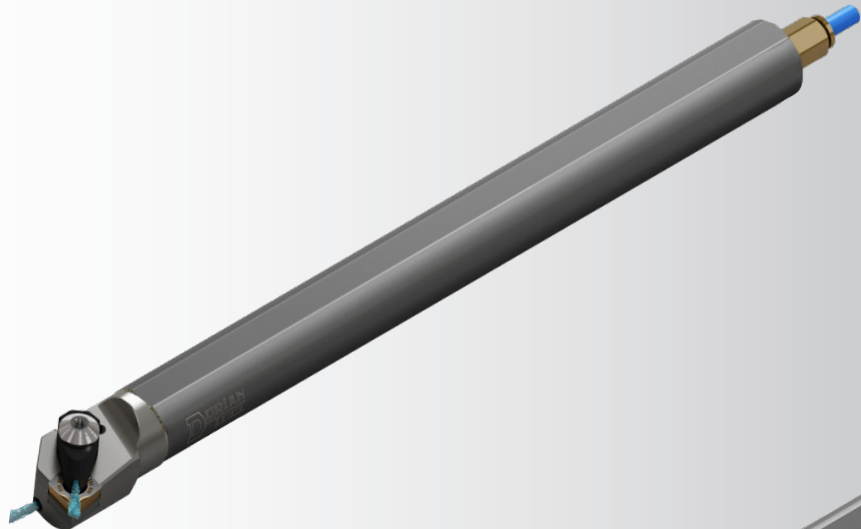

High Performance Carbide Quick Change Modular Thru Coolant Bars

- For large bores
- Carbide Body
- Boring System Shank Size
Inch 0.750" to 1.250"
Metric 20mm to 32mm
- Threading System Shank Size
Inch 0.750" to 1.250"
Metric 20mm to 20mm

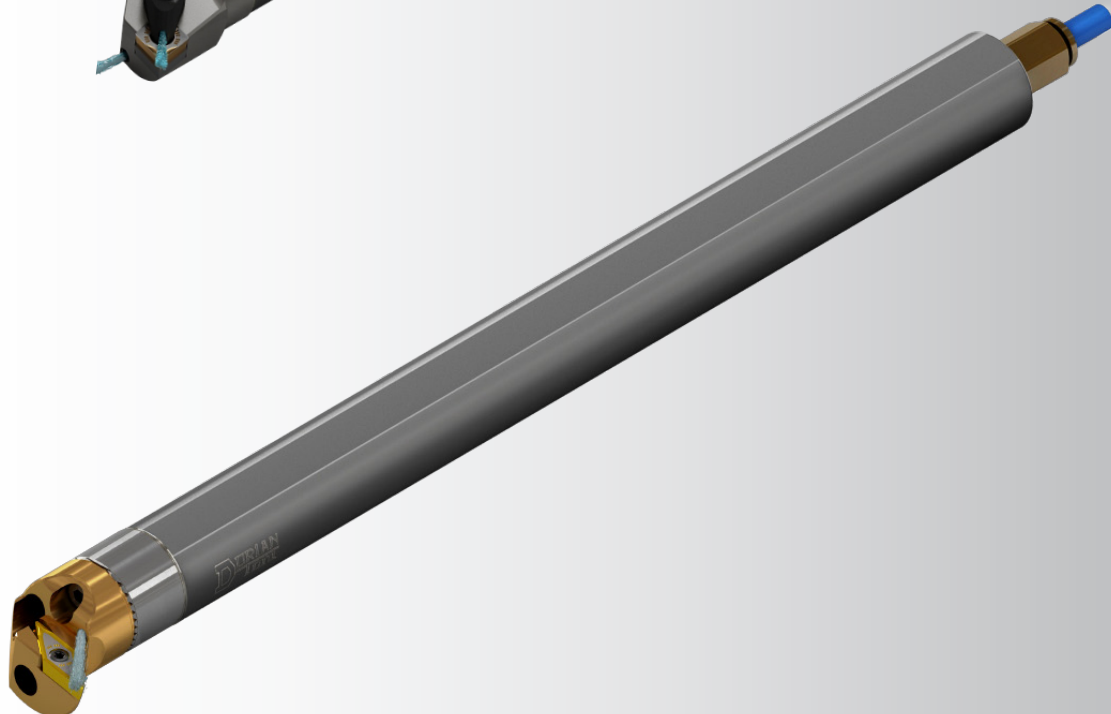

High Performance Carbide Boring Bars

High Performance Carbide Integral Boring Bars

Thru Coolant Carbide Boring Bar System

Best Application for:

- Boring and Threading small bore
- Roughing and Finishing Operation
- Close working tolerances
- Deep Boring 6 x Bar Dia.

Better Machining Performance

Higher Workmanship Quality

Longer Cutting Inserts Life

The technology behind the "Carbide Boring Bar System"

The rigidity of the carbide boring bar, will make boring and threading simple and precise, from heavy roughing to precision finishing, with close tolerance and high surface finish.

- Boring Ratio 6 x Bar Dia.
- Threading Ratio 3 x Bar Dia.

Boring Bar Sizes

Inch: 0.156" Dia., to 1.250" Dia.

Metric: 4mm Dia., to 32mm Dia.,

Boring Bar Heads

Positive Insert Geometry:

CCGT CPGT DPGT

TCGT TPGT VCGT WCGT

Threading Heads

for Lay-Down Insert:

06-A60 08-A60

11-A60 16-A60

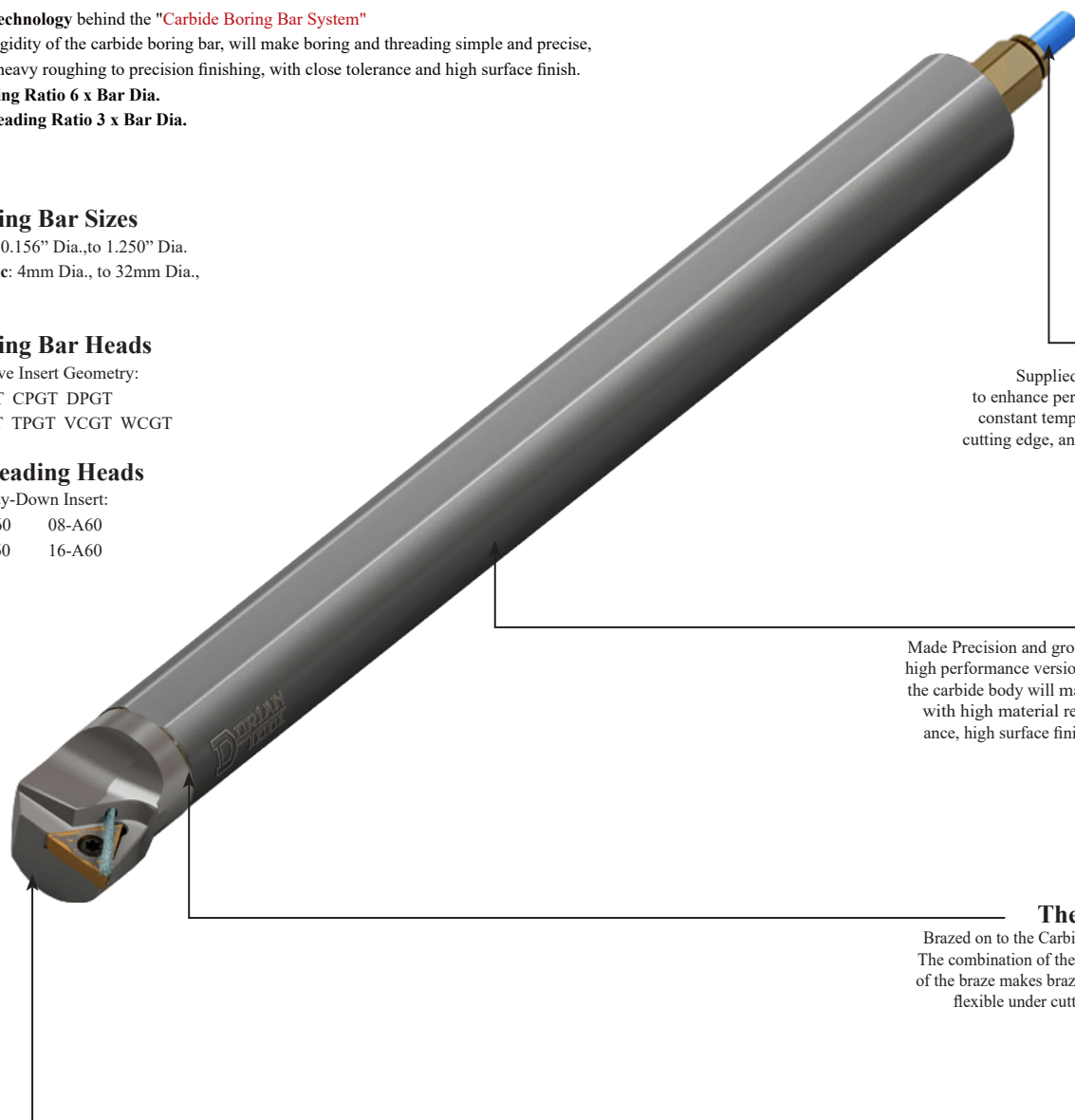

Thru Coolant

Supplied with the thru coolant system to enhance performance, keep the insert at a constant temperature clean and undamaged cutting edge, and remove chips from the bore while machining.

Carbide Body

Made Precision and ground solid Alloyed Carbide for high performance version. The rigidity and stability of the carbide body will maximize boring performance with high material removal, close machining tolerance, high surface finish and deep boring (6 x Dia.)

The Insert Head Braze

Brazed on to the Carbide Bar with triple silver alloys. The combination of the correct alloy and the thickness of the braze makes brazing strong and unbreakable but flexible under cutting pressure and interrupt cuts.

The Insert Heads

Made of heat treated alloy steel, and precisely machined on the body after brazing. Thru Coolant System to improve performance, precision and insert life.

High Performance Carbide Boring Bars

E_SCLD R/L Thru Coolant Integral Carbide Boring Bar Style L - Negative 5° End & Side Cutting Edge Angle for 15° positive 80° diamond CD__inserts

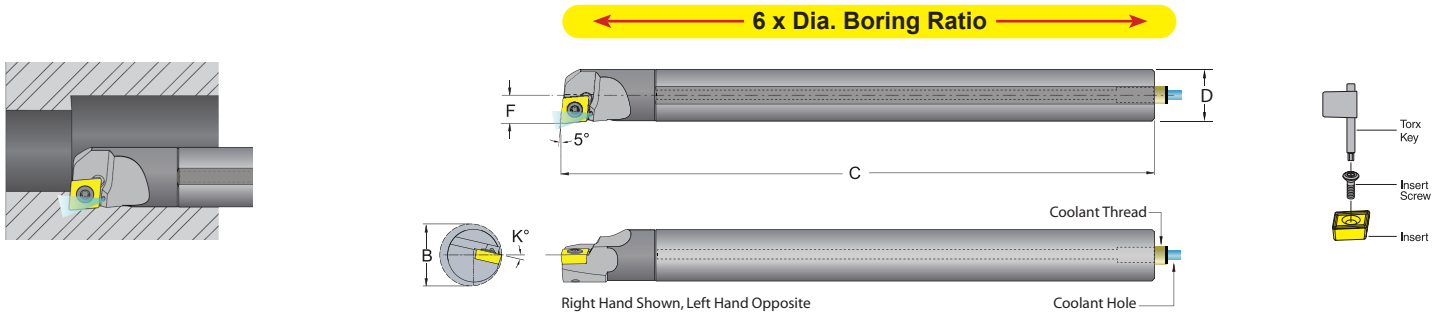

INCH													
Bar Description	UPC No. 733101-R.H.	L.H.	Boring Ratio*	Min. Bore B	C	D	F	K°	Coolant Hole	Coolant Thread	CDGB Gage Insert	Insert Torx Screw	Torx Key
E02.5H-SCLDR/L-1.2	59575	59576	6 x Dia.	0.175	4.00	0.156	0.093	12°	.040	None	1.20.60.2	TS-18.35-1M1	T-6
E03.0H-SCLDR/L-1.2	59579	59580		0.205	4.00	0.187	0.103	9°	.040	None	1.20.60.2	TS-18.35-3M1	T-6
E03.5H-SCLDR/L-1.2	59583	59584		0.245	4.00	0.218	0.123	7°	.040	None	1.510.5	TS-18.35-3M1	T-6
E04H-SCLDR/L-1.5	59587	59588		0.270	4.00	0.250	0.135	7°	.040	None			
E05K-SCLDR/L-1.5	59591	59592		0.335	5.00	0.312	0.167	7°	.040	None			

METRIC													
Bar Description	UPC No. 733101-R.H.	L.H.	Boring Ratio*	Min. Bore B	C	D	F	K°	Coolant Hole	Coolant Thread	CDGB Gage Insert	Insert Torx Screw	Torx Key
E04M-H-SCLDR/L-03	59577	59578	6 x Dia.	4.45	100	4	2.36	12°	1.0	None	S4T001	TS-18.35-1M1	T-6
E05M-H-SCLDR/L-03	59581	59582		5.21	100	5	2.62	9°	1.0	None	S4T001	TS-18.35-3M1	T-6
E06M-H-SCLDR/L-03	59585	59586		6.22	100	6	3.12	7°	1.0	None	040102	TS-18.35-3M1	T-6
E07M-H-SCLDR/L-04	59589	59590		6.86	100	7	3.43	7°	1.0	None			
E08M-K-SCLDR/L-04	59593	59594		8.51	125	8	4.24	7°	1.0	None			

*8 x Dia. Boring Ratio can be achieved under favorable conditions.

High Performance Carbide Boring Bars

E_SCLC R/L Thru Coolant Integral Carbide Boring Bar Style L - Negative 5° End & Side Cutting Edge Angle for 7° positive 80° diamond CC__ inserts

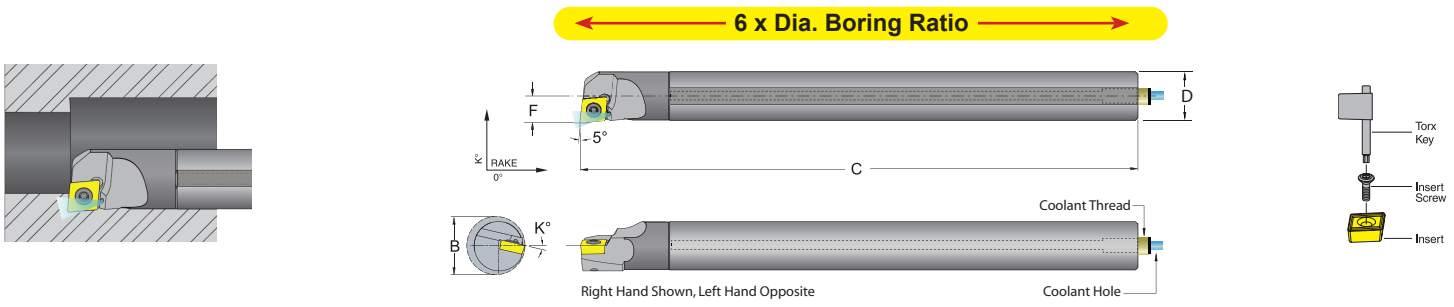

INCH													
Bar Description	UPC No. 733101-R.H.	UPC No. 733101-L.H.	Boring Ratio*	Min. Bore B	C	D	F	K°	Coolant Hole	Coolant Thread	CCGW Gage Insert	Insert Torx Screw	Torx Key
E06M-SCLCR/L-2	59595	59596	6 x Dia.	0.396	6.00	0.375	0.198	15°	.060	None	21.51	TS-25.45-6M2	T-8
E08K-SCLCR/L-2	59599	59600		0.550	5.00	0.500	0.275	13°	.080	6 X 1mm			
E08R-SCLCR/L-2	59603	59604		0.550	8.00	0.500	0.275	13°	.080	6 X 1mm			
E10M-SCLCR/L-2	59607	59608		0.740	6.00	0.625	0.395	10°	.125	6 X 1mm			
E10S-SCLCR/L-2	59611	59612		0.740	10.00	0.625	0.395	10°	.125	6 X 1mm			
E08K-SCLCR/L-3	59615	59616		0.550	5.00	0.500	0.275	13°	.080	6 X 1mm			
E08R-SCLCR/L-3	59619	59620		0.550	8.00	0.500	0.275	13°	.080	6 X 1mm			
E10M-SCLCR/L-3	59623	59624		0.740	6.00	0.625	0.395	10°	.125	6 X 1mm			
E10S-SCLCR/L-3	59627	59628		0.740	10.00	0.625	0.395	10°	.125	6 X 1mm			
E12Q-SCLCR/L-3	59967	59968		0.930	7.000	0.750	0.500	8°	0.157	1/8"-27	32.52	TS-35.6-7M1	T-15
E12S-SCLCR/L-3	59969	59970		0.930	10.00	0.750	0.500	8°	0.157	1/8"-27			
E16R-SCLCR/L-3	59971	59972		1.200	8.000	1.000	0.625	7°	0.197	1/8"-27			
E16T-SCLCR/L-3	59973	59974		1.200	12.00	1.000	0.625	7°	0.197	1/8"-27			
E20U-SCLCR/L-4	59975	59976		1.470	14.00	1.250	0.765	5°	0.197	1/8"-27	432	TS-5.8-10M1	T-20

METRIC													
Bar Description	UPC No. 733101-R.H.	UPC No. 733101-L.H.	Boring Ratio*	Min. Bore B	C	D	F	K°	Coolant Hole	Coolant Thread	CCGW Gage Insert	Insert Torx Screw	Torx Key
E10M-M-SCLCR/L-06	59597	59598	6 x Dia.	10.06	150	10	5.03	15°	1.5	None	060204	TS-25.45-6M2	T-8
E12M-K-SCLCR/L-06	59601	59602		13.97	125	12	6.99	13°	2	6 X 1mm			
E12M-R-SCLCR/L-06	59605	59606		13.97	200	12	6.99	13°	2	6 X 1mm			
E16M-M-SCLCR/L-06	59609	59610		18.80	150	16	10.03	10°	3	6 X 1mm			
E16M-S-SCLCR/L-06	59613	59614		18.80	250	16	10.03	10°	3	6 X 1mm			
E12M-K-SCLCR/L-09	59617	59618		13.97	125	12	6.99	13°	2	6 X 1mm			
E12M-R-SCLCR/L-09	59621	59622		13.97	200	12	6.99	13°	2	6 X 1mm			
E16M-M-SCLCR/L-09	59625	59626		18.80	150	16	10.03	10°	3	6 X 1mm			
E16M-S-SCLCR/L-09	59629	59630		18.80	250	16	10.03	10°	3	6 X 1mm			
E20M-Q-SCLCR/L-09	59977	59978		23.6	180	20	12.70	8°	4	1/8"-27	09T308	TS-35.6-7M1	T-15
E20M-S-SCLCR/L-09	59979	59980		23.6	250	20	12.70	8°	4	1/8"-27			
E25M-R-SCLCR/L-09	59981	59982		30.5	200	25	15.88	7°	5	1/8"-27			
E25M-T-SCLCR/L-09	59983	59984		30.5	300	25	15.88	7°	5	1/8"-27			
E32M-U-SCLCR/L-12	59985	59986		37.3	350	32	19.43	5°	5	1/8"-27	120408	TS-5.8-10M1	T-20

*8 x Dia. Boring Ratio can be achieved under favorable conditions.

High Performance Carbide Boring Bars

E_SCLP R/L Thru Coolant Integral Carbide Boring Bar Style L - Negative 5° End & Side Cutting Edge Angle for 11° positive 80° diamond CP__ inserts

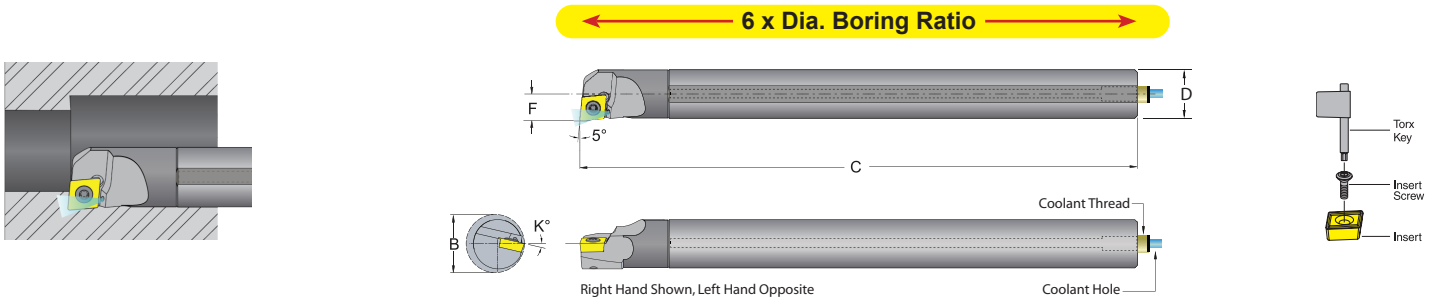

INCH													
Bar Description	UPC No. 733101- R.H.	L.H.	Boring Ratio*	Min. Bore B	C	D	F	K°	Coolant Hole	Coolant Thread	CPGW Gage Insert	Insert Torx Screw	Torx Key
E05K-SCLPR/L-1.8	59631	59632	6 x Dia.	0.335	5.00	0.312	0.167	7°	.040	None	1.81.20.5	TS-22.45-4M1	T-7
E06M-SCLPR/L-2	59635	59636		0.396	6.00	0.375	0.198	6°	.060	None	21.51	TS-25.45-6M2	T-8
E08K-SCLPR/L-2	59639	59640		0.550	5.00	0.500	0.275	3°	.080	6 X 1mm			
E08R-SCLPR/L-2	59643	59644		0.550	8.00	0.500	0.275	3°	.080	6 X 1mm			
E10M-SCLPR/L-2	59647	59648		0.740	6.00	0.625	0.395	2°	.125	6 X 1mm			
E10S-SCLPR/L-2	59651	59652		0.740	10.00	0.625	0.395	2°	.125	6 X 1mm	32.52	TS-35.6-7M1	T-15
E08K-SCLPR/L-3	59655	59656		0.550	5.00	0.500	0.280	9°	.080	6 X 1mm			
E08R-SCLPR/L-3	59659	59660		0.550	8.00	0.500	0.280	9°	.080	6 X 1mm			
E10M-SCLPR/L-3	59663	59664		0.740	6.00	0.625	0.395	5°	.125	6 X 1mm			
E10S-SCLPR/L-3	59667	59668		0.740	10.00	0.625	0.395	5°	.125	6 X 1mm			

METRIC													
Bar Description	UPC No. 733101- R.H.	L.H.	Boring Ratio*	Min. Bore B	C	D	F	K°	Coolant Hole	Coolant Thread	CPGW Gage Insert	Insert Torx Screw	Torx Key
E10M-M-SCLPR/L-06	59637	59638	6 x Dia.	10.06	150	10	5.03	6°	1.5	None	060204	TS-25.45-6M2	T-8
E12M-K-SCLPR/L-06	59641	59642		13.97	125	12	6.99	3°	2	6 X 1mm			
E12M-R-SCLPR/L-06	59645	59646		13.97	200	12	6.99	3°	2	6 X 1mm			
E16M-M-SCLPR/L-06	59649	59650		18.80	150	16	10.03	2°	3	6 X 1mm			
E16M-S-SCLPR/L-06	59653	59654		18.80	250	16	10.03	2°	3	6 X 1mm	09T308	TS-35.6-7M1	T-15
E12M-K-SCLPR/L-09	59657	59658		13.97	125	12	7.11	9°	2	6 X 1mm			
E12M-R-SCLPR/L-09	59661	59662		13.97	200	12	7.11	9°	2	6 X 1mm			
E16M-M-SCLPR/L-09	59665	59666		18.80	150	16	10.03	5°	3	6 X 1mm			
E16M-S-SCLPR/L-09	59669	59670		18.80	250	16	10.03	5°	3	6 X 1mm			

*8 x Dia. Boring Ratio can be achieved under favorable conditions.

High Performance Carbide Boring Bars

E_SDNC R/L Thru Coolant Integral Carbide Boring Bar Style N - Negative 27.5° End & Side Cutting Edge Angle for 7° positive 55° diamond DC__ inserts

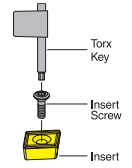
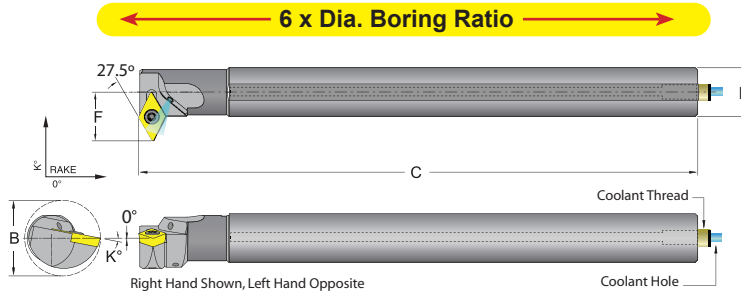
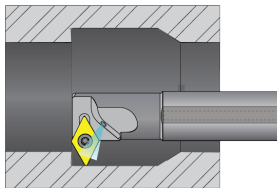

INCH													
Bar Description	UPC No. 733101-R.H.	UPC No. 733101-L.H.	Boring Ratio*	Min. Bore B	C	D	F	K°	Coolant Hole	Coolant Thread	DCMT Gage Insert	Insert Torx Screw	Torx Key
E06M-SDNCR/L-2	59671	59672	6 x Dia.	0.581	6.00	0.375	0.375	11°	.060	none	21.51	TS-25.45-6M2	T-8
E08K-SDNCR/L-2	59675	59676		0.775	5.00	0.500	0.500	11°	.080	6 X 1mm			
E08R-SDNCR/L-2	59679	59680		0.775	8.00	0.500	0.500	11°	.080	6 X 1mm			
E10M-SDNCR/L-2	59683	59684		0.969	6.00	0.625	0.625	7°	.125	6 X 1mm			
E10S-SDNCR/L-2	59687	59688		0.969	10.00	0.625	0.625	7°	.125	6 X 1mm			

METRIC													
Bar Description	UPC No. 733101-R.H.	UPC No. 733101-L.H.	Boring Ratio*	Min. Bore B	C	D	F	K°	Coolant Hole	Coolant Thread	DCMT Gage Insert	Insert Torx Screw	Torx Key
E10M-M-SDNCR/L-07	59673	59674	6 x Dia.	14.76	150	10	9.53	11°	1.5	None	070204	TS-25.45-6M2	T-8
E12M-K-SDNCR/L-07	59677	59678		19.69	125	12	12.70	11°	2	6 X 1mm			
E12M-R-SDNCR/L-07	59681	59682		19.69	200	12	12.70	11°	2	6 X 1mm			
E16M-M-SDNCR/L-07	59685	59686		24.61	150	16	15.88	7°	3	6 X 1mm			
E16M-S-SDNCR/L-07	59689	59690		24.61	250	16	15.88	7°	3	6 X 1mm			

*8 x Dia. Boring Ratio can be achieved under favorable conditions.

High Performance Carbide Boring Bars

E_SDQC R/L Thru Coolant Integral Carbide Boring Bar Style Q - Negative 17.5° End Cutting Edge Angle for 7° positive 55° diamond DC__ inserts

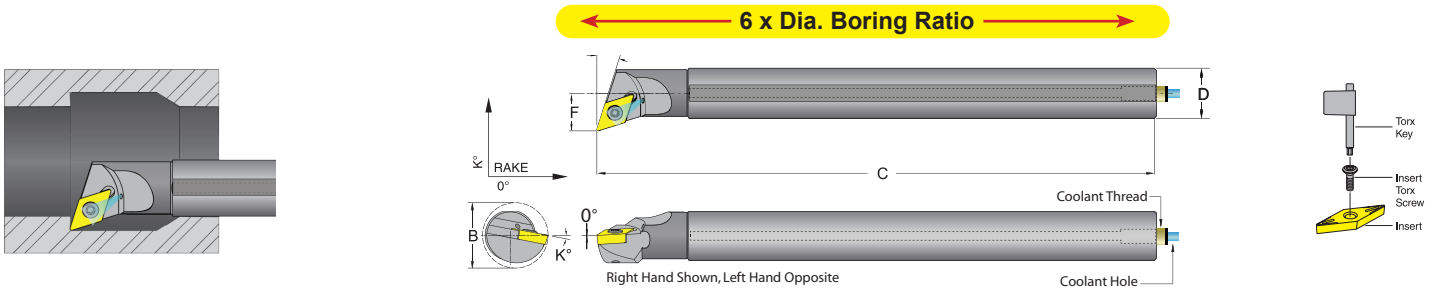

INCH													
Bar Description	UPC No. 733101-		Boring Ratio*	Min. Bore					Coolant Hole	Coolant Thread	DCMT Gage Insert	Insert Torx Screw	Torx Key
	R.H.	L.H.		B	C	D	F	K°					
E06M-SDQCR/L-2	59691	59692	6 x Dia.	0.487	6.00	0.375	0.281	11°	.060	None	21.51	TS-25.45-6M2	T-8
E08K-SDQCR/L-2	59695	59696		0.650	5.00	0.500	0.375	11°	.080	6 X 1mm			
E08R-SDQCR/L-2	59699	59700		0.650	8.00	0.500	0.375	11°	.080	6 X 1mm			
E10M-SDQCR/L-2	59703	59704		0.781	6.00	0.625	0.437	7°	.125	6 X 1mm			
E10S-SDQCR/L-2	59707	59708		0.781	10.00	0.625	0.437	7°	.125	6 X 1mm			

METRIC													
Bar Description	UPC No. 733101-		Boring Ratio*	Min. Bore					Coolant Hole	Coolant Thread	DCMT Gage Insert	Insert Torx Screw	Torx Key
	R.H.	L.H.		B	C	D	F	K°					
E10M-M-SDQCR/L-07	59693	59694	6 x Dia.	12.38	150	10	7.14	11°	1.5	None	070204	TS-25.45-6M2	T-8
E12M-K-SDQCR/L-07	59697	59698		16.51	125	12	9.53	11°	2	6 X 1mm			
E12M-R-SDQCR/L-07	59701	59702		16.51	200	12	9.53	11°	2	6 X 1mm			
E16M-M-SDQCR/L-07	59705	59706		19.83	150	16	11.10	7°	3	6 X 1mm			
E16M-S-SDQCR/L-07	59709	59710		19.83	250	16	11.10	7°	3	6 X 1mm			

*8 x Dia. Boring Ratio can be achieved under favorable conditions.

High Performance Carbide Boring Bars

E_SDUC R/L Thru Coolant Integral Carbide Boring Bar Style U - Negative 3° End Cutting Edge Angle for 7° positive 55° diamond DC__ inserts

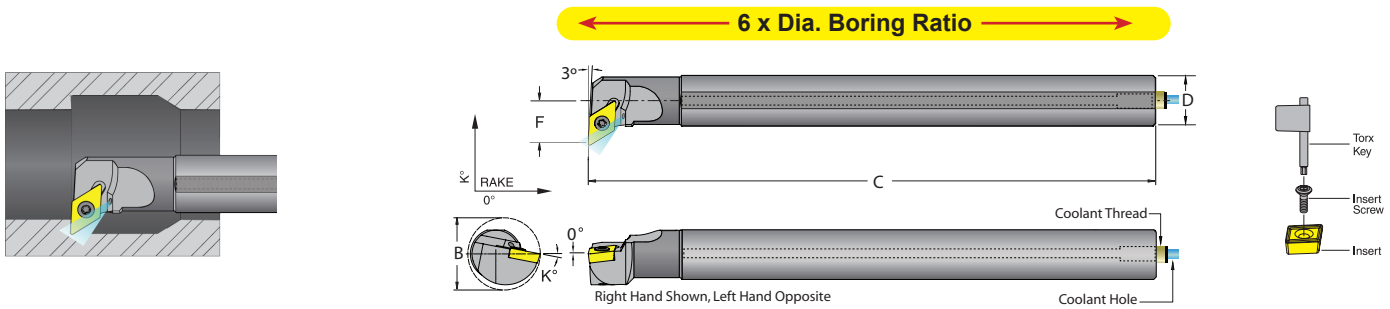

INCH													
Bar Description	UPC No. 733101- R.H.	UPC No. 733101- L.H.	Boring Ratio*	Min. Bore B	C	D	F	K°	Coolant Hole	Coolant Thread	DCMT Gage Insert	Insert Torx Screw	Torx Key
E06M-SDUCR/L-2	59711	59712	6 x Dia.	0.581	6.00	0.375	0.375	11°	.060	None	21.51	TS-25.45-6M2	T-8
E08K-SDUCR/L-2	59715	59716		0.712	5.00	0.500	0.437	11°	.080	6 X 1mm			
E08R-SDUCR/L-2	59719	59720		0.712	8.00	0.500	0.437	11°	.080	6 X 1mm			
E10M-SDUCR/L-2	59723	59724		0.844	6.00	0.625	0.500	7°	.125	6 X 1mm	32.52	TS-35.6-9M1	T-15
E10S-SDUCR/L-2	59727	59728		0.844	10.00	0.625	0.500	7°	.125	6 X 1mm			
E12Q-SDUCR/L-3	59987	59988		1.050	7.000	0.750	0.562	6°	0.157	1/8"-27			
E12S-SDUCR/L-3	59989	59990		1.050	10.00	0.750	0.562	6°	0.157	1/8"-27			
E16R-SDUCR/L-3	59991	59992		1.300	8.000	1.000	0.750	4°	0.197	1/8"-27			
E16T-SDUCR/L-3	59993	59994		1.300	12.00	1.000	0.750	4°	0.197	1/8"-27			
E20U-SDUCR/L-3	59995	59996		1.750	14.00	1.250	0.875	4°	0.197	1/8"-27			

METRIC													
Bar Description	UPC No. 733101- R.H.	UPC No. 733101- L.H.	Boring Ratio*	Min. Bore B	C	D	F	K°	Coolant Hole	Coolant Thread	DCMT Gage Insert	Insert Torx Screw	Torx Key
E10M-M-SDUCR/L-07	59713	59714	6 x Dia.	14.76	150	10	9.53	11°	1.5	None	070204	TS-25.45-6M2	T-8
E12M-K-SDUCR/L-07	59717	59718		18.08	125	12	11.10	11°	2	6 X 1mm			
E12M-R-SDUCR/L-07	59721	59722		18.08	200	12	11.10	11°	2	6 X 1mm			
E16M-M-SDUCR/L-07	59725	59726		21.43	150	16	12.70	7°	3	6 X 1mm	11T308	TS-35.6-9M1	T-15
E16M-S-SDUCR/L-07	59729	59730		21.43	250	16	12.70	7°	3	6 X 1mm			
E20M-Q-SDUCR/L-11	59997	59998		26.7	180	20	14.27	6°	4	1/8"-27			
E20M-S-SDUCR/L-11	59999	60000		26.7	250	20	14.27	6°	4	1/8"-27			
E25M-R-SDUCR/L-11	60001	60002		33.0	200	25	19.05	4°	5	1/8"-27			
E25M-T-SDUCR/L-11	60003	60004		33.0	300	25	19.05	4°	5	1/8"-27			
E32M-U-SDUCR/L-11	60005	60006		44.5	350	32	22.23	4°	5	1/8"-27			

*8 x Dia. Boring Ratio can be achieved under favorable conditions.

High Performance Carbide Boring Bars

E_SDXC R/L Thru Coolant Integral Carbide Boring Bar Style X - Negative 5° Back Boring Cutting Edge Angle for 7° positive 55° diamond DC__ inserts

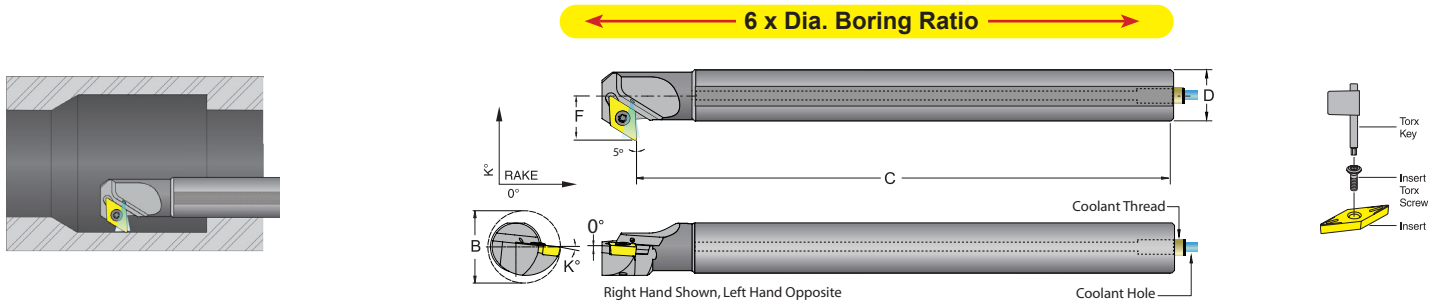

INCH													
Bar Description	UPC No. 733101-R.H.	L.H.	Boring Ratio*	Min. Bore B	C	D	F	K°	Coolant Hole	Coolant Thread	DCMT Gage Insert	Insert Torx Screw	Torx Key
E06M-SDXCR/L-2	59731	59732	6 x Dia.	0.581	5.66	0.375	0.375	8°	.060	None	21.51	TS-25.45-6M2	T-8
E08K-SDXCR/L-2	59735	59736		0.712	4.66	0.500	0.437	6°	.080	6 X 1mm			
E08R-SDXCR/L-2	59739	59740		0.712	7.66	0.500	0.437	6°	.080	6 X 1mm			
E10M-SDXCR/L-2	59743	59744		0.844	5.66	0.625	0.500	5°	.125	6 X 1mm			
E10S-SDXCR/L-2	59747	59748		0.844	9.66	0.625	0.500	5°	.125	6 X 1mm			
E12Q-SDXCR/L-3	60007	60008		0.980	7.000	0.750	0.562	5°	0.157	1/8"-27	32.52	TS-35.6-9M1	T-15
E12S-SDXCR/L-3	60009	60010		0.980	10.00	0.750	0.562	5°	0.157	1/8"-27			
E16R-SDXCR/L-3	60011	60012		1.300	8.000	1.000	0.750	3°	0.197	1/8"-27			
E16T-SDXCR/L-3	60013	60014		1.300	12.00	1.000	0.750	3°	0.197	1/8"-27			
E20U-SDXCR/L-3	60015	60016		1.600	14.00	1.250	1.000	3°	0.197	1/8"-27			

METRIC													
Bar Description	UPC No. 733101-R.H.	L.H.	Boring Ratio*	Min. Bore B	C	D	F	K°	Coolant Hole	Coolant Thread	DCMT Gage Insert	Insert Torx Screw	Torx Key
E10M-M-SDXCR/L-07	59733	59734	6 x Dia.	14.76	141.36	10	9.53	8°	1.5	None	070204	TS-25.45-6M2	T-8
E12M-K-SDXCR/L-07	59737	59738		18.08	116.36	12	11.10	6°	2	6 X 1mm			
E12M-R-SDXCR/L-07	59741	59742		18.08	191.36	12	11.10	6°	2	6 X 1mm			
E16M-M-SDXCR/L-07	59745	59746		21.43	141.36	16	12.70	5°	3	6 X 1mm			
E16M-S-SDXCR/L-07	59749	59750		21.43	241.36	16	12.70	5°	3	6 X 1mm			
E20M-Q-SDXCR/L-11	60017	60018		24.9	180	20	14.27	5°	4	1/8"-27	11T308	TS-35.6-9M1	T-15
E20M-S-SDXCR/L-11	60019	60020		24.9	250	20	14.27	5°	4	1/8"-27			
E25M-R-SDXCR/L-11	60021	60022		33.0	200	25	19.05	3°	5	1/8"-27			
E25M-T-SDXCR/L-11	60023	60024		33.0	300	25	19.05	3°	5	1/8"-27			
E32M-U-SDXCR/L-11	60025	60026		40.6	350	32	25.40	3°	5	1/8"-27			

*8 x Dia. Boring Ratio can be achieved under favorable conditions.

High Performance Carbide Boring Bars

E_STUC R/L Thru Coolant Integral Carbide Boring Bar Style U - Negative 3° End Cutting Edge Angle for 7° positive triangle TC__ inserts

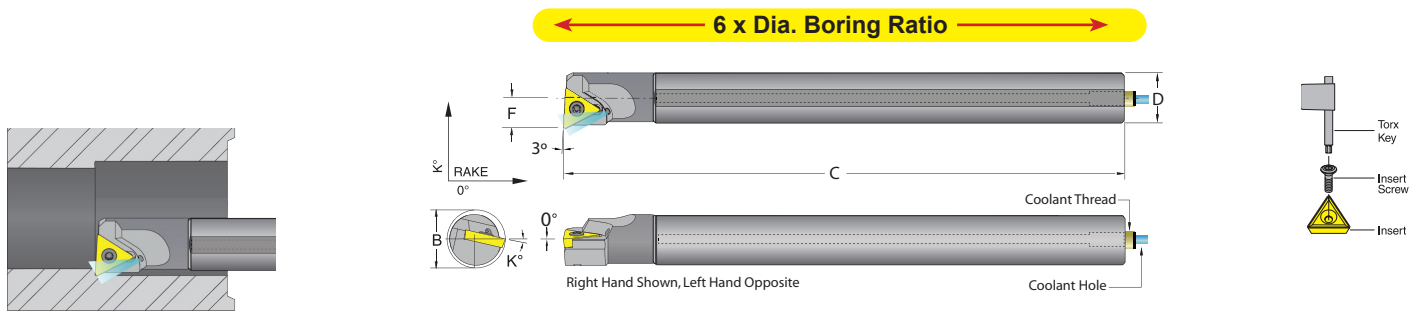

INCH													
Bar Description	UPC No. 733101- R.H.	L.H.	Boring Ratio*	Min. Bore B	C	D	F	K°	Coolant Hole	Coolant Thread	TCMT Gage Insert	Insert Torx Screw	Torx Key
E04H-STUCR/L-1.2	59751	59752	6 x Dia.	0.281	4.00	0.250	0.143	11°	.060	None	1.21.20.2	TS-06	T-6
E05K-STUCR/L-1.2	59755	59756		0.339	5.00	0.312	0.167	8°	.060	None			
E06M-STUCR/L-1.2	59759	59760		0.409	6.00	0.375	0.203	7°	.060	None			
E06M-STUCR/L-2	59763	59764		0.456	6.00	0.375	0.250	15°	.060	None	21.51	TS-25.45-6M2	T-8
E08K-STUCR/L-2	59767	59768		0.587	5.00	0.500	0.312	13°	.080	6 X 1mm			
E08R-STUCR/L-2	59771	59772		0.587	8.00	0.500	0.312	13°	.080	6 X 1mm	32.52	TS-35.6-9M1	T-15
E10M-STUCR/L-2	59775	59776		0.750	6.00	0.625	0.406	10°	.125	6 X 1mm			
E10S-STUCR/L-2	59779	59780		0.750	10.00	0.625	0.406	10°	.125	6 X 1mm			
E12Q-STUCR/L-3	60027	60028		0.930	7.000	0.750	0.500	8°	0.157	1/8"-27	06T101	TS-06	T-6
E12S-STUCR/L-3	60029	60030		0.930	10.00	0.750	0.500	8°	0.157	1/8"-27			
E16R-STUCR/L-3	60031	60032		1.200	8.000	1.000	0.625	7°	0.197	1/8"-27	06T308	TS-35.6-9M1	T-15
E16T-STUCR/L-3	60033	60034		1.200	12.00	1.000	0.625	7°	0.197	1/8"-27			
E20U-STUCR/L-3	60035	60036		1.470	14.00	1.250	0.875	7°	0.197	1/8"-27			

METRIC													
Bar Description	UPC No. 733101- R.H.	L.H.	Boring Ratio*	Min. Bore B	C	D	F	K°	Coolant Hole	Coolant Thread	TCMT Gage Insert	Insert Torx Screw	Torx Key
E07M-H-STUCR/L-06	59753	59754	6 x Dia.	7.14	100	7	3.63	11°	1.5	None	110204	TS-25.45-6M2	T-8
E08M-K-STUCR/L-06	59757	59758		8.60	125	8	4.24	8°	1.5	None			
E10M-M-STUCR/L-06	59761	59762		10.39	150	10	5.16	7°	1.5	None			
E10M-M-STUCR/L-11	59765	59766		11.59	150	10	6.35	15°	1.5	None	06T101	TS-06	T-6
E12M-K-STUCR/L-11	59769	59770		14.91	125	12	7.92	13°	2	6 X 1mm			
E12M-R-STUCR/L-11	59773	59774		14.91	200	12	7.92	13°	2	6 X 1mm	06T308	TS-35.6-9M1	T-15
E16M-M-STUCR/L-11	59777	59778		19.04	150	16	10.31	10°	3	6 X 1mm			
E16M-S-STUCR/L-11	59781	59782		19.04	250	16	10.31	10°	3	6 X 1mm			
E20M-Q-STUCR/L-16	60037	60038		23.6	180	20	12.70	8°	4	1/8"-27	06T308	TS-35.6-9M1	T-15
E20M-S-STUCR/L-16	60039	60040		23.6	250	20	12.70	8°	4	1/8"-27			
E25M-R-STUCR/L-16	60041	60042		30.5	200	25	15.88	7°	5	1/8"-27	06T308	TS-35.6-9M1	T-15
E25M-T-STUCR/L-16	60043	60044		30.5	300	25	15.88	7°	5	1/8"-27			
E32M-U-STUCR/L-16	60045	60046		37.3	350	32	22.23	7°	5	1/8"-27			

*8 x Dia. Boring Ratio can be achieved under favorable conditions.

High Performance Carbide Boring Bars

E_STUP R/L Thru Coolant Integral Carbide Boring Bar Style U - Negative 3° End Cutting Edge Angle for 11° positive triangle TP__ inserts

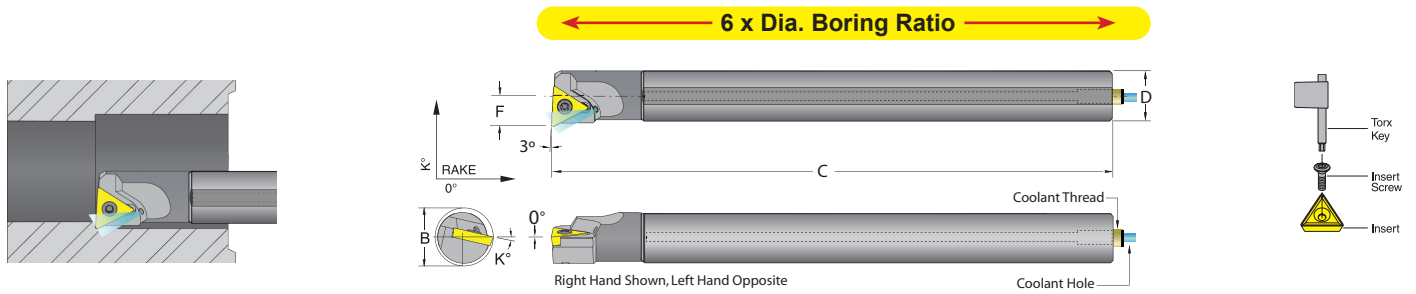

Inch			Boring Ratio*	Min. Bore					Coolant Hole	Coolant Thread	TPMT Gage Insert	Insert Torx Screw	Torx Key
Bar Description	UPC No. 733101-R.H.	L.H.		B	C	D	F	K°					
E06M-STUPR/L-2	59783	59784	6 x Dia.	0.456	6.00	0.375	0.250	4°	.060	None	21.51	TS-25.45-6M2	T-8
E08K-STUPR/L-2	59787	59788		0.587	5.00	0.500	0.312	2°	.080	6 X 1mm			
E08R-STUPR/L-2	59791	59792		0.587	8.00	0.500	0.312	2°	.080	6 X 1mm			
E10M-STUPR/L-2	59795	59796		0.750	6.00	0.625	0.406	0°	.125	6 X 1mm			
E10S-STUPR/L-2	59799	59800		0.750	10.00	0.625	0.406	0°	.125	6 X 1mm			

Metric			Boring Ratio*	Min. Bore					Coolant Hole	Coolant Thread	TPMT Gage Insert	Insert Torx Screw	Torx Key
Bar Description	UPC No. 733101-R.H.	L.H.		B	C	D	F	K°					
E10M-M-STUPR/L-11	59785	59786	6 x Dia.	11.59	150	10	6.35	4°	1.5	None	110204	TS-25.45-6M2	T-8
E12M-K-STUPR/L-11	59789	59790		14.91	125	12	7.92	2°	2	6 X 1mm			
E12M-R-STUPR/L-11	59793	59794		14.91	200	12	7.92	2°	2	6 X 1mm			
E16M-M-STUPR/L-11	59797	59798		19.04	150	16	10.31	0°	3	6 X 1mm			
E16M-S-STUPR/L-11	59801	59802		19.04	250	16	10.31	0°	3	6 X 1mm			

*8 x Dia. Boring Ratio can be achieved under favorable conditions.

E_SVMC R/L Thru Coolant Integral Carbide Boring Bar Style M - Negative 50° Side Cutting Edge Angle for 7° positive 35° diamond VC__ inserts

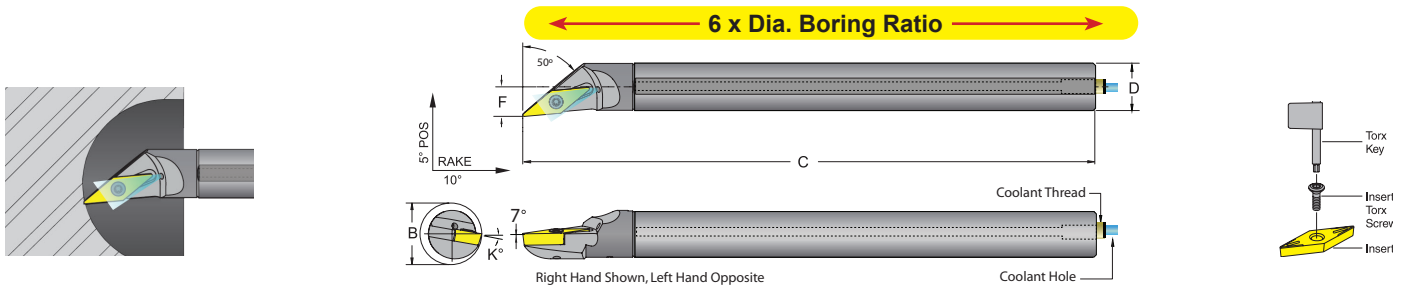

INCH													
Bar Description	UPC No. 733101-R.H.	L.H.	Boring Ratio*	Min. Bore					Coolant Hole	Coolant Thread	VCMT Gage Insert	Insert Torx Screw	Torx Key
				B	C	D	F	K°					
E08K-SVMCR/L-2	59803	59804	6 x Dia.	0.587	5.23	0.500	0.312	8°	.080	6 X 1mm	221	TS-25.45-8M2	T-8
E08R-SVMCR/L-2	59807	59808		0.587	8.23	0.500	0.312	8°	.080	6 X 1mm			
E10M-SVMCR/L-2	59811	59812		0.750	6.16	0.625	0.406	8°	.125	6 X 1mm			
E10S-SVMCR/L-2	59815	59816		0.750	10.16	0.625	0.406	8°	.125	6 X 1mm			

METRIC													
Bar Description	UPC No. 733101-R.H.	L.H.	Boring Ratio*	Min. Bore					Coolant Hole	Coolant Thread	VCMT Gage Insert	Insert Torx Screw	Torx Key
				B	C	D	F	K°					
E12M-K-SVMCR/L-11	59805	59806	6 x Dia.	14.910	130.84	12	7.925	8°	2	6 X 1mm	110304	TS-25.45-8M2	T-8
E12M-R-SVMCR/L-11	59809	59810		14.910	205.84	12	7.925	8°	2	6 X 1mm			
E16M-M-SVMCR/L-11	59813	59814		19.044	154.06	16	10.312	8°	3	6 X 1mm			
E16M-S-SVMCR/L-11	59817	59818		19.044	254.06	16	10.312	8°	3	6 X 1mm			

*8 x Dia. Boring Ratio can be achieved under favorable conditions.

High Performance Carbide Boring Bars

E_SVQC R/L Thru Coolant Integral Carbide Boring Bar Style Q - Negative 17.5° End Cutting Edge Angle for 7° positive 35° diamond VC__ inserts

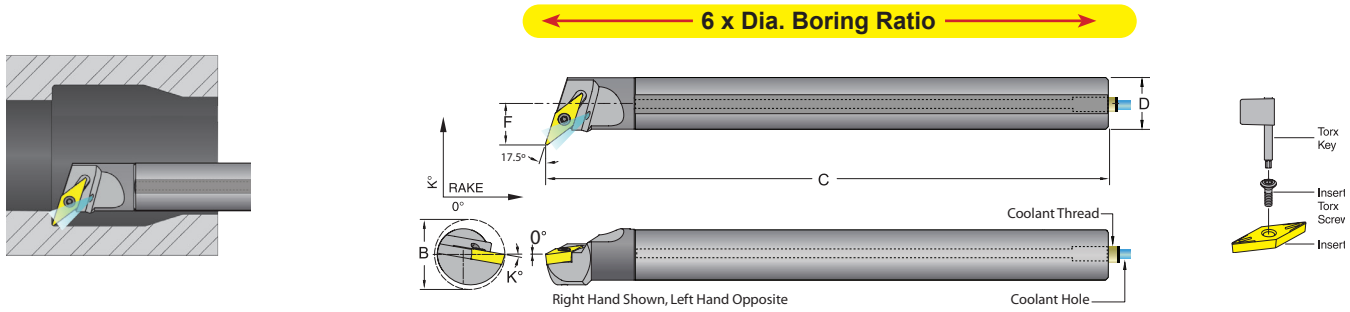

INCH													
Bar Description	UPC No. 733101-R.H.	L.H.	Boring Ratio*	Min. Bore B	C	D	F	K°	Coolant Hole	Coolant Thread	VCMT Gage Insert	Insert Torx Screw	Torx Key
E10M-SVQCR/L-2	59819	59820	6 x Dia.	0.844	6.00	0.625	0.500	10°	.125	6 X 1mm	221	TS-25.45-8M2	T-8
E10S-SVQCR/L-2	59823	59824		0.844	10.00	0.625	0.500	10°	.125	6 X 1mm			

METRIC													
Bar Description	UPC No. 733101-R.H.	L.H.	Boring Ratio*	Min. Bore B	C	D	F	K°	Coolant Hole	Coolant Thread	VCMT Gage Insert	Insert Torx Screw	Torx Key
E16M-M-SVQCR/L-11	59821	59822	6 x Dia.	21.43	150	16	12.70	10°	3	6 X 1mm	110304	TS-25.45-8M2	T-8
E16M-S-SVQCR/L-11	59825	59826		21.43	250	16	12.70	10°	3	6 X 1mm			

*8 x Dia. Boring Ratio can be achieved under favorable conditions.

E_SVUC R/L Thru Coolant Integral Carbide Boring Bar Style U - Negative 3° End Cutting Edge Angle for 7° positive 35° diamond VC__ inserts

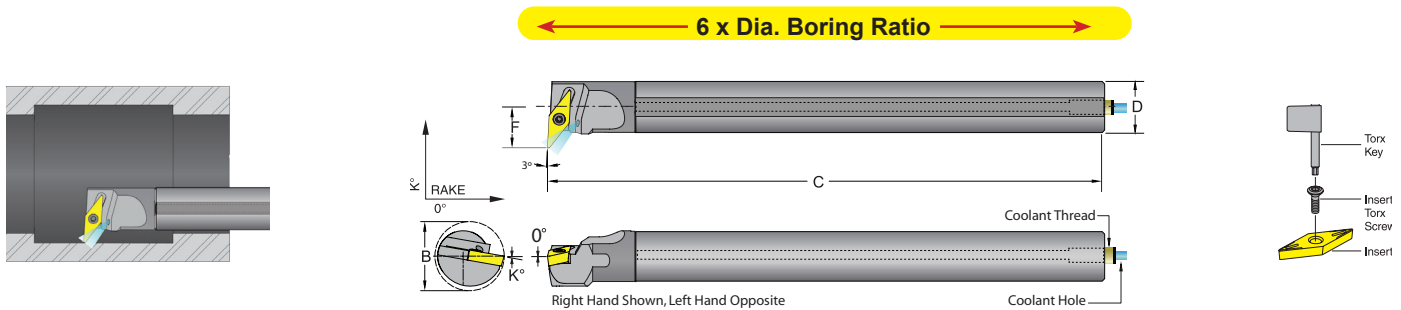

INCH													
Bar Description	UPC No. 733101-R.H.	L.H.	Boring Ratio*	Min. Bore B	C	D	F	K°	Coolant Hole	Coolant Thread	VCMT Gage Insert	Insert Torx Screw	Torx Key
E10M-SVUCR/L-2	59827	59828	6 x Dia.	0.844	6.00	0.625	0.500	10°	.125	6 X 1mm	221	TS-25.45-8M2	T-8
E10S-SVUCR/L-2	59831	59832		0.844	10.00	0.625	0.500	10°	.125	6 X 1mm			

METRIC													
Bar Description	UPC No. 733101-R.H.	L.H.	Boring Ratio*	Min. Bore B	C	D	F	K°	Coolant Hole	Coolant Thread	VCMT Gage Insert	Insert Torx Screw	Torx Key
E16M-M-SVUCR/L-11	59829	59830	6 x Dia.	21.43	150	16	12.70	10°	3	6 X 1mm	110304	TS-25.45-8M2	T-8
E16M-S-SVUCR/L-11	59833	59834		21.43	250	16	12.70	10°	3	6 X 1mm			

*8 x Dia. Boring Ratio can be achieved under favorable conditions.

High Performance Carbide Boring Bars

E_SVXC R/L Thru Coolant Integral Carbide Boring Bar Style X - Negative 5° Back Boring Cutting Edge Angle for 7° positive 35° diamond VC__ inserts

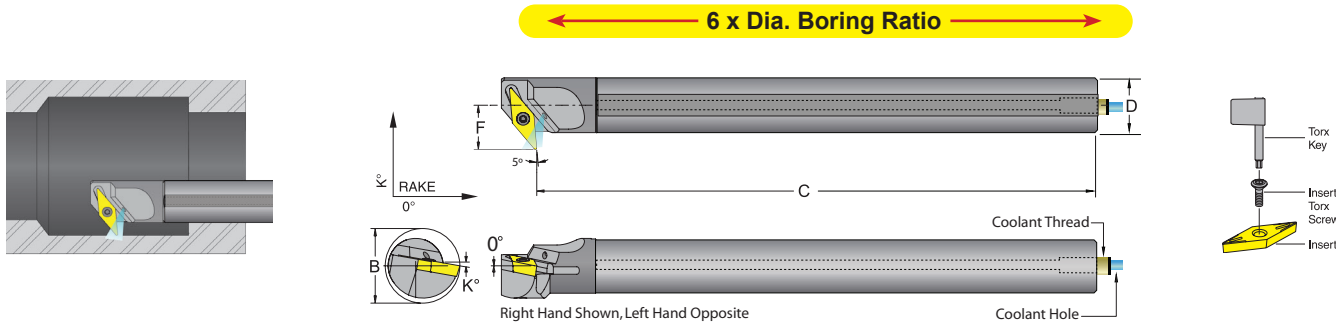

INCH														
Bar Description	UPC No. 733101-		Boring Ratio*	Min. Bore		C	D	F	K°	Coolant Hole	Coolant Thread	VCMT Gage Insert	Insert Torx Screw	Torx Key
	R.H.	L.H.		B	B									
E10M-SVXCR/L-2	59835	59836	6 x Dia.	1.0	5.76	0.625	.625	10°	.125	6 X 1mm	221	TS-25.45-8M2	T-8	
E10S-SVXCR/L-2	59839	59840		1.0	9.76	0.625	.625	10°	.125	6 X 1mm				

METRIC														
Bar Description	UPC No. 733101-		Boring Ratio*	Min. Bore		C	D	F	K°	Coolant Hole	Coolant Thread	VCMT Gage Insert	Insert Torx Screw	Torx Key
	R.H.	L.H.		B	B									
E16M-M-SVXCR/L-11	59837	59838	6 x Dia.	25.40	143.90	16	15.88	10°	3	6 X 1mm	110304	TS-25.45-8M2	T-8	
E16M-S-SVXCR/L-11	59841	59842		25.40	243.90	16	15.88	10°	3	6 X 1mm				

*8 x Dia. Boring Ratio can be achieved under favorable conditions.

E_SVQP R/L Thru Coolant Integral Carbide Boring Bar Style Q - Negative 17.5° End Cutting Edge Angle for 11° positive 35° diamond VP__ inserts

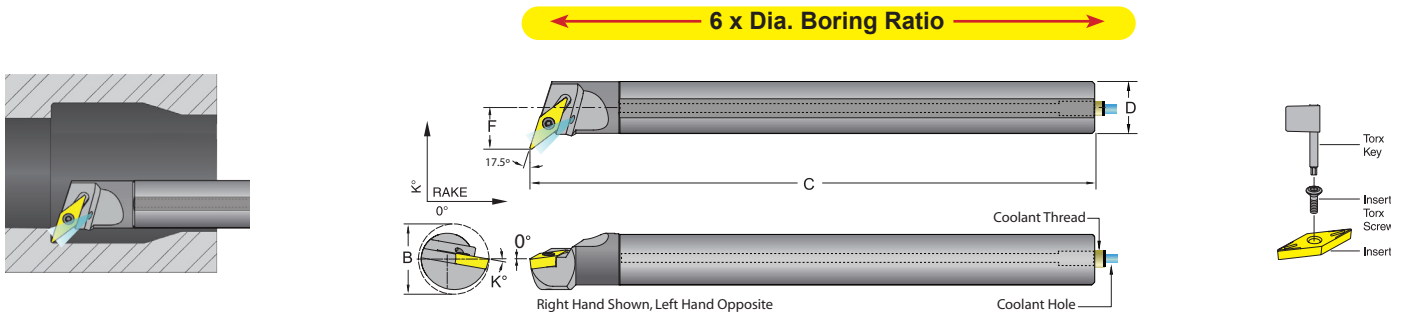

INCH														
Bar Description	UPC No. 733101-		Boring Ratio*	Min. Bore		C	D	F	K°	Coolant Hole	Coolant Thread	VPMT Gage Insert	Insert Torx Screw	Torx Key
	R.H.	L.H.		B	B									
E10M-SVQPR/L-2	59843	59844	6 x Dia.	0.844	6.00	0.625	0.500	6°	.125	6 X 1mm	221	TS-25.45-8M2	T-8	
E10S-SVQPR/L-2	59847	59848		0.844	10.00	0.625	0.500	6°	.125	6 X 1mm				

METRIC														
Bar Description	UPC No. 733101-		Boring Ratio*	Min. Bore		C	D	F	K°	Coolant Hole	Coolant Thread	VPMT Gage Insert	Insert Torx Screw	Torx Key
	R.H.	L.H.		B	B									
E16M-M-SVQPR/L-11	59845	59846	6 x Dia.	21.43	150	16	12.70	6°	3	6 X 1mm	110304	TS-25.45-8M2	T-8	
E16M-S-SVQPR/L-11	59849	59850		21.43	250	16	12.70	6°	3	6 X 1mm				

*8 x Dia. Boring Ratio can be achieved under favorable conditions.

High Performance Carbide Boring Bars

E_SVUP R/L Thru Coolant Integral Carbide Boring Bar Style U - Negative 3° End Cutting Edge Angle for 11° positive 35° diamond VP__ inserts

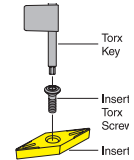
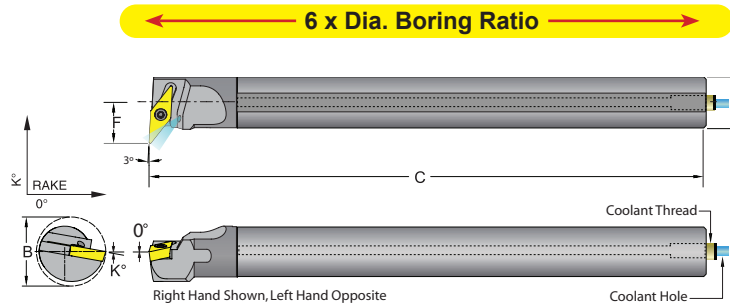
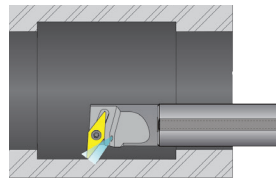

INCH													
Bar Description	UPC No. 733101-R.H.	L.H.	Boring Ratio*	Min. Bore B	C	D	F	K°	Coolant Hole	Coolant Thread	VPMT Gage Insert	Insert Torx Screw	Torx Key
E10M-SVUPR/L-2	59851	59852	6 x Dia.	0.844	6.00	0.625	0.500	6°	.125	6 X 1mm	221	TS-25.45-8M2	T-8
E10S-SVUPR/L-2	59855	59856		0.844	10.00	0.625	0.500	6°	.125	6 X 1mm			

METRIC													
Bar Description	UPC No. 733101-R.H.	L.H.	Boring Ratio*	Min. Bore B	C	D	F	K°	Coolant Hole	Coolant Thread	VPMT Gage Insert	Insert Torx Screw	Torx Key
E16M-M-SVUPR/L-11	59853	59854	6 x Dia.	21.43	150	16	12.70	6°	3	6 X 1mm	110304	TS-25.45-8M2	T-8
E16M-S-SVUPR/L-11	59857	59858		21.43	250	16	12.70	6°	3	6 X 1mm			

*8 x Dia. Boring Ratio can be achieved under favorable conditions.

E_SVXP R/L Thru Coolant Integral Carbide Boring Bar Style X - Negative 5° Back Boring Cutting Edge Angle for 11° positive 35° diamond VP__ inserts

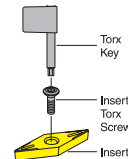
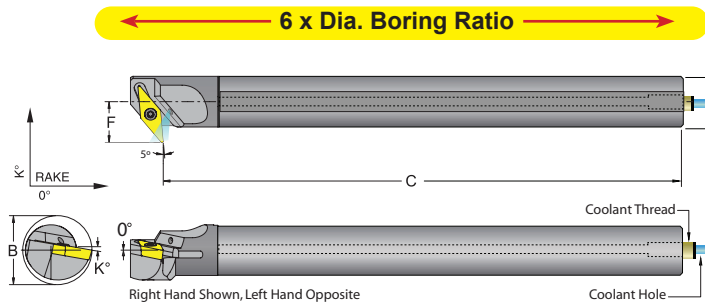
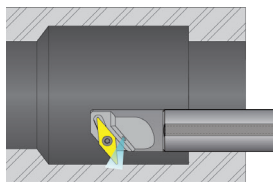

INCH													
Bar Description	UPC No. 733101-R.H.	L.H.	Boring Ratio*	Min. Bore B	C	D	F	K°	Coolant Hole	Coolant Thread	VPMT Gage Insert	Insert Torx Screw	Torx Key
E10M-SVXPR/L-2	59859	59860	6 x Dia.	1.00	5.76	0.625	.625	6°	.125	6 X 1mm	221	TS-25.45-8M2	T-8
E10S-SVXPR/L-2	59863	59864		1.00	9.76	0.625	.625	6°	.125	6 X 1mm			

METRIC													
Bar Description	UPC No. 733101-R.H.	L.H.	Boring Ratio*	Min. Bore B	C	D	F	K°	Coolant Hole	Coolant Thread	VPMT Gage Insert	Insert Torx Screw	Torx Key
E16M-M-SVXPR/L-11	59861	59862	6 x Dia.	25.4	143.90	16	15.88	6°	3	6 X 1mm	110304	TS-25.45-8M2	T-8
E16M-S-SVXPR/L-11	59865	59866		25.4	243.90	16	15.88	6°	3	6 X 1mm			

*8 x Dia. Boring Ratio can be achieved under favorable conditions.

High Performance Carbide Boring Bars

E_SWLCL R/L Thru Coolant Integral Carbide Boring Bar Style L - Negative 5° End Cutting Edge Angle for 7° positive 80° trigon WC__ inserts

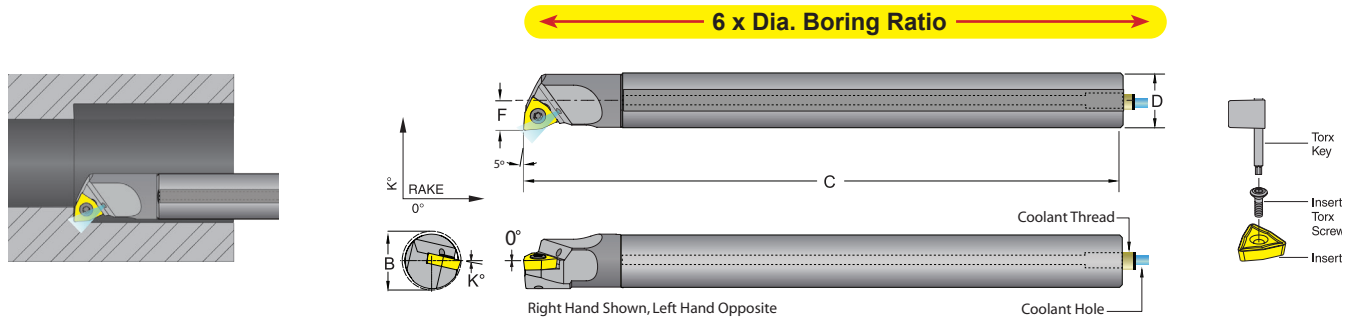

INCH													
Bar Description	UPC No. 733101-R.H.	UPC No. 733101-L.H.	Boring Ratio*	Min. Bore B	C	D	F	K°	Coolant Hole	Coolant Thread	WCMT Gage Insert	Insert Torx Screw	Torx Key
E03.0H-SWLCL R/L-1.2	59867	59868	6 x Dia.	0.205	4.00	0.187	0.103	13°	.040	None	1.210.2	TS-18.35-1M1	T-6
E03.5H-SWLCL R/L-1.2	59871	59872		0.245	4.00	0.218	0.125	11°	.040	None			
E04H-SWLCL R/L-1.2	59875	59876		0.270	4.00	0.250	0.135	9°	.040	None			
E05K-SWLCL R/L-1.2	59879	59880		0.335	5.00	0.312	0.167	7°	.040	None			
E06M-SWLCL R/L-2	59883	59884		0.396	6.00	0.375	0.198	15°	.060	None			
E08K-SWLCL R/L-2	59887	59888		0.550	5.00	0.500	0.275	13°	.080	6 X 1mm			
E08R-SWLCL R/L-2	59891	59892		0.550	8.00	0.500	0.275	13°	.080	6 X 1mm	21.51	TS-25.45-6M2	T-8
E10M-SWLCL R/L-2	59895	59896		0.740	6.00	0.625	0.395	10°	.125	6 X 1mm			
E10S-SWLCL R/L-2	59899	59900		0.740	10.00	0.625	0.395	10°	.125	6 X 1mm			
E08K-SWLCL R/L-3	59903	59904		0.550	5.00	0.500	0.275	13°	.080	6 X 1mm	32.52	TS-35.6-9M1	T-15
E08R-SWLCL R/L-3	59907	59908		0.550	8.00	0.500	0.275	13°	.080	6 X 1mm			
E10M-SWLCL R/L-3	59911	59912		0.740	6.00	0.625	0.395	10°	.125	6 X 1mm			
E10S-SWLCL R/L-3	59915	59916		0.740	10.00	0.625	0.395	10°	.125	6 X 1mm			
E12Q-SWLCL R/L-3	60047	60048		0.930	7.000	0.750	0.500	10°	0.157	1/8"-27			
E12S-SWLCL R/L-3	60049	60050		0.930	10.00	0.750	0.500	10°	0.157	1/8"-27			
E16R-SWLCL R/L-3	60051	60052		1.200	8.000	1.000	0.625	5°	0.197	1/8"-27	432	TS-5.8-10M1	T-20
E16T-SWLCL R/L-3	60053	60054	1.200	12.00	1.000	0.625	5°	0.197	1/8"-27				
E20U-SWLCL R/L-4	60055	60056	1.530	14.00	1.250	0.765	5°	0.197	1/8"-27				

METRIC													
Bar Description	UPC No. 733101-R.H.	UPC No. 733101-L.H.	Boring Ratio*	Min. Bore B	C	D	F	K°	Coolant Hole	Coolant Thread	WCMT Gage Insert	Insert Torx Screw	Torx Key
E05M-H-SWLCL R/L-02	59869	59870	6 x Dia.	5.21	100	5	2.62	13°	1	None	S20101	TS-18.35-1M1	T-6
E06M-H-SWLCL R/L-02	59873	59874		6.22	100	6	3.18	11°	1	None			
E07M-H-SWLCL R/L-02	59877	59878		6.86	100	7	3.43	9°	1	None			
E08M-K-SWLCL R/L-02	59881	59882		8.51	125	8	4.24	7°	1	None			
E10M-M-SWLCL R/L-04	59885	59886		10.06	150	10	5.03	15°	1.5	None			
E12M-K-SWLCL R/L-04	59889	59890		13.97	125	12	6.99	13°	2	6 X 1mm			
E12M-R-SWLCL R/L-04	59893	59894		13.97	200	12	6.99	13°	2	6 X 1mm	040204	TS-25.45-6M2	T-8
E16M-M-SWLCL R/L-04	59897	59898		18.80	150	16	10.03	10°	3	6 X 1mm			
E16M-S-SWLCL R/L-04	59901	59902		18.80	250	16	10.03	10°	3	6 X 1mm			
E12M-K-SWLCL R/L-06	59905	59906		13.97	125	12	6.99	13°	2	6 X 1mm	06T308	TS-35.6-9M1	T-15
E12M-R-SWLCL R/L-06	59909	59910		13.97	200	12	6.99	13°	2	6 X 1mm			
E16M-M-SWLCL R/L-06	59913	59914		18.80	150	16	10.03	10°	3	6 X 1mm			
E16M-S-SWLCL R/L-06	59917	59918		18.80	250	16	10.03	10°	3	6 X 1mm			
E20M-Q-SWLCL R/L-06	60057	60058		23.6	180	20	12.70	10°	4	1/8"-27			
E20M-S-SWLCL R/L-06	60059	60060		23.6	250	20	12.70	10°	4	1/8"-27			
E25M-R-SWLCL R/L-06	60061	60062		30.5	200	25	15.88	5°	5	1/8"-27	080408	TS-5.8-10M1	T-20
E25M-T-SWLCL R/L-06	60063	60064	30.5	300	25	15.88	5°	5	1/8"-27				
E32M-U-SWLCL R/L-08	60065	60066	38.9	350	32	19.43	5°	5	1/8"-27				

*8 x Dia. Boring Ratio can be achieved under favorable conditions.

High Performance Carbide Boring Bars

E_SN R/L Thru Coolant Integral Carbide Threading Bar Internal Laydown Bar for Laydown Inserts

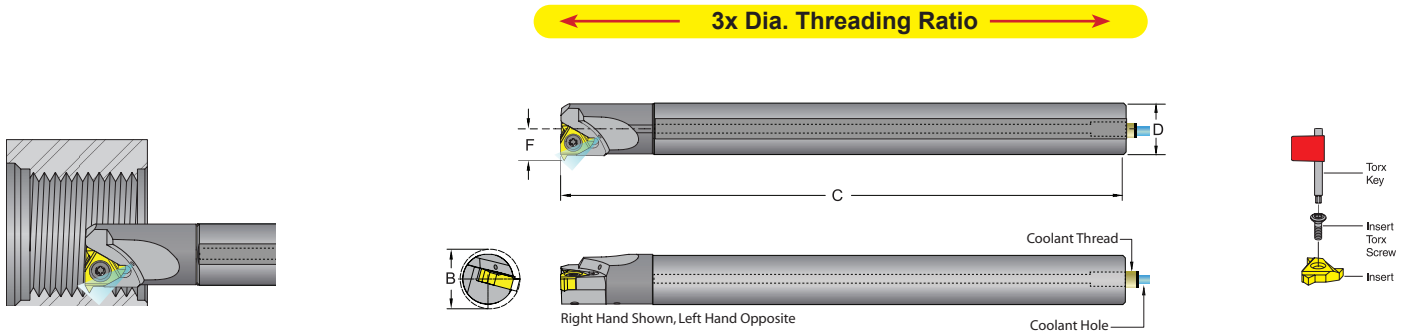

INCH												
Bar Description	UPC No. 733101- R.H. L.H.		Boring Ratio*	Min. Bore B	C	D	F	Coolant Hole	Coolant Thread	Laydown Gage Insert	Insert Torx Screw	Torx Key
E03.5H-SNR/L-06	59919	59920	6 x Dia.	0.249	4.00	0.218	0.129	.040	None	06-A60	TS-06	T-6
E04H-SNR/L-06	59923	59924		0.307	4.00	0.250	0.165	.040	None			
E05K-SNR/L-08	59927	59928		0.378	5.00	0.312	0.215	.040	None	08-A60	TS-08	T-8
E06M-SNR/L-H11	59931	59932		0.500	6.00	0.375	0.250	.060	None	11-A60	TS-25.45-6M2	T-8
E08K-SNR/L-H11	59935	59936		0.590	5.00	0.500	0.315	.080	6 X 1mm			
E08R-SNR/L-H11	59939	59940		0.590	8.00	0.500	0.315	.080	6 X 1mm			
E10M-SNR/L-H16	59943	59944		0.750	6.00	0.625	0.406	.125	6 X 1mm	16-A60	TS-35.6-9M1	T-15
E10S-SNR/L-H16	59947	59948		0.750	10.00	0.625	0.406	.125	6 X 1mm			

METRIC												
Bar Description	UPC No. 733101- R.H. L.H.		Boring Ratio*	Min. Bore B	C	D	F	Coolant Hole	Coolant Thread	Laydown Gage Insert	Insert Torx Screw	Torx Key
E06M-H-SNR/L-06	59921	59922	6 x Dia.	6.32	100	6	3.28	1	None	06-A60	TS-06	T-6
E07M-H-SNR/L-06	59925	59926		7.80	100	7	4.19	1	None			
E08M-K-SNR/L-08	59929	59930		9.60	125	8	5.46	1	None	08-A60	TS-08	T-8
E10M-M-SNR/L-H11	59933	59934		12.70	150	10	6.35	1.5	None	11-A60	TS-25.45-6M2	T-8
E12M-K-SNR/L-H11	59937	59938		14.99	125	12	8.00	2	6 X 1mm			
E12M-R-SNR/L-H11	59941	59942		14.99	200	12	8.00	2	6 X 1mm			
E16M-M-SNR/L-H16	59945	59946		19.04	150	16	10.31	3	6 X 1mm	16-A60	TS-35.6-9M1	T-15
E16M-S-SNR/L-H16	59949	59950		19.04	250	16	10.31	3	6 X 1mm			

*8 x Dia. Boring Ratio can be achieved under favorable conditions.

High Performance Carbide Boring Bars

E_NE R/L Thru Coolant Integral Carbide Threading & Grooving Bar Style E- Internal DorNotch Bar for threading and grooving Dor-Notch inserts

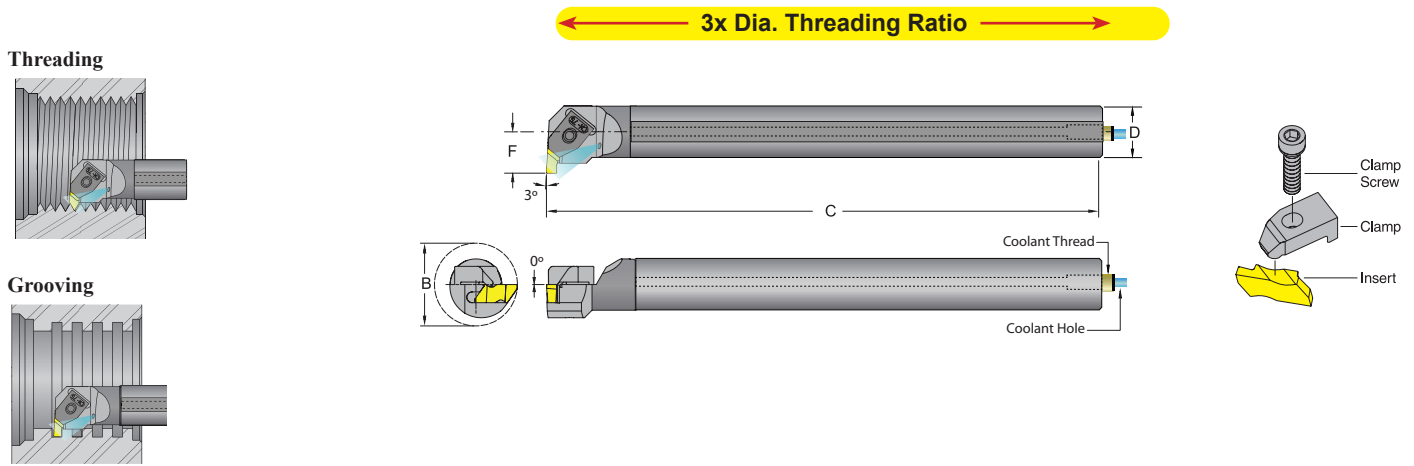

INCH												
Bar Description	UPC No. 733101-		Boring Ratio*	Min. Bore B	C	D	F	Coolant Hole	Coolant Thread	DorNotch Gage Insert	Insert Torx Screw	Torx Key
	R.H.	L.H.										
E08K-NER/L-2	59951	59952	6 x Dia.	0.830	5.12	0.500	0.470	.080	6 X 1mm	*NG-2L **NG-2R	*CM-75 **CM-74	S-310M
E08R-NER/L-2	59955	59956		0.830	8.12	0.500	0.470	.080	6 X 1mm			
E10M-NER/L-2	59959	59960		1.000	6.00	0.625	0.500	.125	6 X 1mm	*NG-2L **NG-2R	*CM-75 **CM-74	S-310M
E10S-NER/L-2	59963	59964		1.000	10.00	0.625	0.500	.125	6 X 1mm			
E12Q-NER/L-2	60169	60170		1.125	6.875	0.750	0.530	0.157	1/8"-27	*NG-2L **NG-2R	*CM-75 **CM-74	S-310M
E12S-NER/L-2	60171	60172		1.125	9.875	0.750	0.530	0.157	1/8"-27			

METRIC												
Bar Description	UPC No. 733101-		Boring Ratio*	Min. Bore B	C	D	F	Coolant Hole	Coolant Thread	DorNotch Gage Insert	Insert Torx Screw	Torx Key
	R.H.	L.H.										
E12M-K-NER/L-2	59953	59954	6 x Dia.	21.08	128.05	12	11.94	2	6 X 1mm	*NG-2L **NG-2R	*CM-75 **CM-74	S-310M
E12M-R-NER/L-2	59957	59958		21.08	203.05	12	11.94	2	6 X 1mm			
E16M-M-NER/L-2	59961	59962		25.40	150	16	12.70	3	6 X 1mm	*NG-2L **NG-2R	*CM-75 **CM-74	S-310M
E16M-S-NER/L-2	59965	59966		25.40	250	16	12.70	3	6 X 1mm			
E20M-Q-NER/L-2	60179	60180		28.6	180	20	14.27	4	1/8"-27	*NG-2L **NG-2R	*CM-75 **CM-74	S-310M
E20M-S-NER/L-2	60181	60182		28.6	250	20	14.27	4	1/8"-27			

*8 x Dia. Boring Ratio can be achieved under favorable conditions.

*For right hand tool. ** For left hand tool

High Performance Jet-Stream™ Carbide Bars

Thru Coolant Carbide Boring & Threading Bars

200% More Insert Life with High Pressure Jet-Stream™!

Better Machining Performance

Higher Workmanship Quality

Longer Cutting Inserts Life

The technology behind the "Carbide Boring Bar System"

the rigidity of the carbide boring bar, will make boring and threading simple and precise, from heavy roughing to precision finishing, with close tolerance and high surface finish.

- Boring Ratio 6 x Bar Dia.
- Threading Ratio 3 x Bar Dia.

Boring Bar Sizes

Inch: .750" Dia., 1" Dia., 1.250" Dia.

Metric: 20mm Dia., 25mm Dia., 32mm Dia.

Boring Bar Heads

Negative Insert Geometry:

CNMG DNMG TNMG

VNMG WNMG

Threading Heads

for Lay-Down Insert:

16-A60 22-N60

for DorNotch Insert:

NG-3



The Insert Head Braze

Brazed on to the Carbide Bar with triple silver alloys. The combination of the correct alloy and the thickness of the braze makes brazing strong and unbreakable but flexible under cutting pressure and interrupt cuts.

Jet-Stream™ Thru Coolant System

At a close range of 1/4" (6mm) the Jet-Stream™ coolant system aims the coolant precisely onto the cutting edge of the insert at a very high velocity. The controlled Jet-Stream™ coolant will lubricate the cutting edge of the insert reducing the coefficient of friction, stopping the chip from adhering to the insert. The physical combination of high velocity and high pressure forces the hot chip to hydroplane away from the cutting edge of the insert.

As a result, the insert will operate at a constant low temperature, With a clean and undamaged cutting edge, changing the way metal is cut!

The Insert Heads

Made of heat treated alloy steel, and precisely machined on the body after brazing. Thru Coolant System to improve performance, precision and insert life

High Performance Carbide Boring Bars

E_ADCLN R/L Thru Coolant Jet-Stream™ Carbide Boring Bar Style L - Negative 5° side & end cutting lead angle for negative 80° diamond CN__inserts

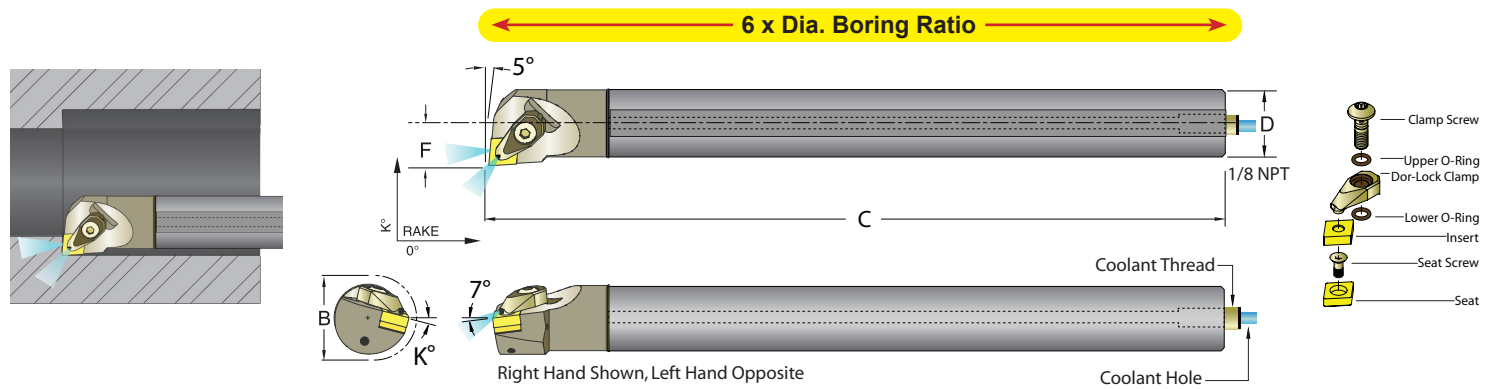

INCH															
Bar Description	UPC No. 733101-R.H.	L.H.	Boring Ratio*	Min. Bore						Coolant Hole	Coolant Thread	CNMG Gage Insert	Seat	Seat Screw	Dor-Lock Clamp
E16R-ADCLNR/L-4	60067	60068	6 x Dia.	1.280	8.000	1.000	0.640	14°	0.197	1/8"-27	432	ICSN-433	SM-S4	JSLC-HPCTW-4N	
E16T-ADCLNR/L-4	60069	60070		1.280	12.00	1.000	0.640	14°	0.197	1/8"-27					
E20U-ADCLNR/L-4	60071	60072		1.530	14.00	1.250	0.765	14°	0.197	1/8"-27					

METRIC															
Bar Description	UPC No. 733101-R.H.	L.H.	Boring Ratio*	Min. Bore						Coolant Hole	Coolant Thread	CNMG Gage Insert	Seat	Seat Screw	Dor-Lock Clamp
E25M-R-ADCLNR/L-12	60073	60074	6 x Dia.	32.5	200	25	16.26	14°	5	1/8"-27	120408	ICSN-433	SM-S4	JSLC-HPCTW-4N	
E25M-T-ADCLNR/L-12	60075	60076		32.5	300	25	16.26	14°	5	1/8"-27					
E32M-U-ADCLNR/L-12	60077	60078		38.9	350	32	19.43	14°	5	1/8"-27					

*8 x Dia. Boring Ratio can be achieved under favorable conditions.

E_ADTURN R/L Thru Coolant Jet-Stream™ Carbide Boring Bar Style U - Negative 3° end cutting lead angle for negative triangle TN__inserts

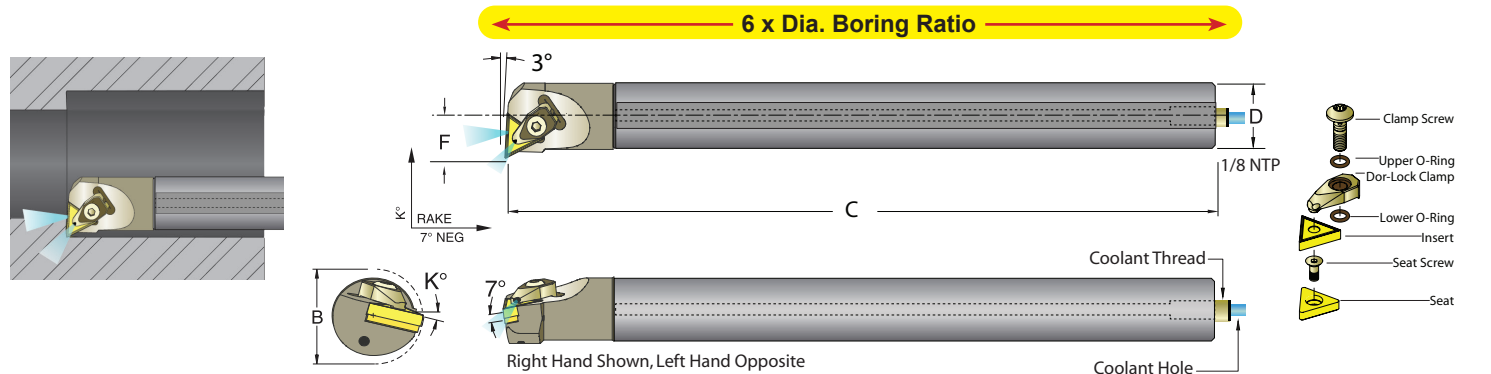

INCH															
Bar Description	UPC No. 733101-R.H.	L.H.	Boring Ratio*	Min. Bore						Coolant Hole	Coolant Thread	TNMG Gage Insert	Seat	Seat Screw	Dor-Lock Clamp
E16R-ADTURNR/L-3	60079	60080	6 x Dia.	1.280	8.000	1.000	0.640	14°	0.197	1/8"-27	332	ITSN-322	SM-S3	JSLC-HPDPT3-BR/L	
E16T-ADTURNR/L-3	60081	60082		1.280	12.00	1.000	0.640	14°	0.197	1/8"-27					
E20U-ADTURNR/L-3	60083	60084		1.530	14.00	1.250	0.765	14°	0.197	1/8"-27					

METRIC															
Bar Description	UPC No. 733101-R.H.	L.H.	Boring Ratio*	Min. Bore						Coolant Hole	Coolant Thread	TNMG Gage Insert	Seat	Seat Screw	Dor-Lock Clamp
E25M-R-ADTURNR/L-16	60085	60086	6 x Dia.	32.5	200	25	16.26	14°	5	1/8"-27	160408	ITSN-322	SM-S3	JSLC-HPDPT3-BR/L	
E25M-T-ADTURNR/L-16	60087	60088		32.5	300	25	16.26	14°	5	1/8"-27					
E32M-U-ADTURNR/L-16	60089	60090		38.9	350	32	19.43	14°	5	1/8"-27					

*8 x Dia. Boring Ratio can be achieved under favorable conditions. *Right clamp for right hand toolholder. Left clamp for left hand toolholder

High Performance Carbide Boring Bars

E_ADDUN R/L Thru Coolant Jet-Stream™ Carbide Boring Bar Style U Negative 3° end cutting lead angle for negative 55° diamond DN__ inserts

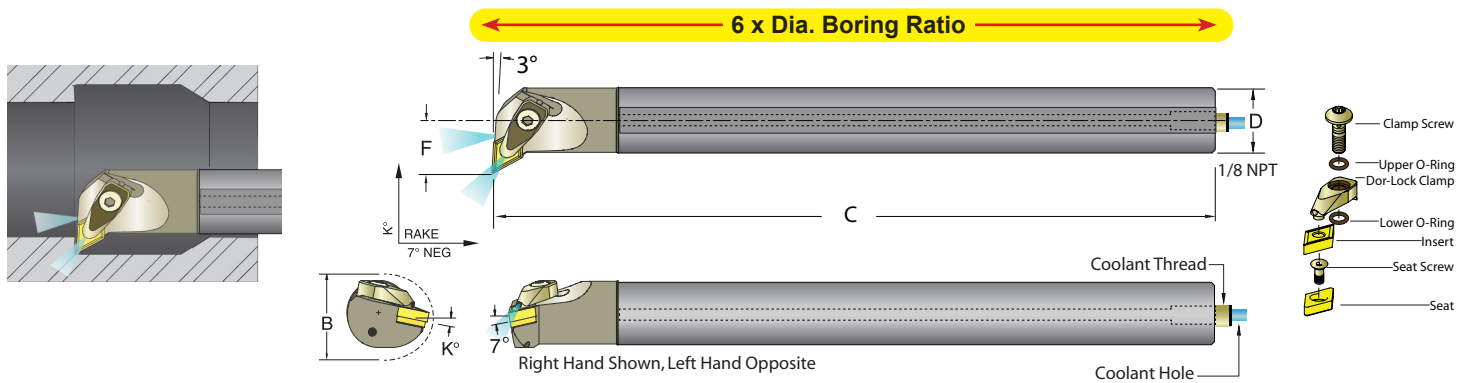

INCH														
Bar Description	UPC No. 733101-		Boring Ratio*	Min. Bore				Coolant Hole	Coolant Thread	DNMG Gage Insert				Dor-Lock Clamp
	R.H.	L.H.		B	C	D	F			K°	Seat	Seat Screw	Seat	
E16R-ADDUNR/L-3	60093	60094	6 x Dia.	1.300	8.000	1.000	0.750	14°	0.197	1/8"-27	332	DD-32.52	TS-35.6-9M1	JSLC-HPDT3-BR/L
E16T-ADDUNR/L-3	60095	60096		1.300	12.00	1.000	0.750	14°	0.197	1/8"-27				
E20U-ADDUNR/L-4	60097	60098		2.000	14.00	1.250	1.000	11°	0.197	1/8"-27	432	DD-432	TS-5.8-10M1	JSLC-HPD4

METRIC														
Bar Description	UPC No. 733101-		Boring Ratio*	Min. Bore				Coolant Hole	Coolant Thread	DNMG Gage Insert				Dor-Lock Clamp
	R.H.	L.H.		B	C	D	F			K°	Seat	Seat Screw	Seat	
E25M-R-ADDUNR/L-11	60099	60100	6 x Dia.	33.0	200	25	19.05	14°	5	1/8"-27	110408	DD-32.52	TS-35.6-9M1	JSLC-HPDT3-BR/L
E25M-T-ADDUNR/L-11	60101	60102		33.0	300	25	19.05	14°	5	1/8"-27				
E32M-U-ADDUNR/L-15	60107	60108		50.8	350	32	25.40	11°	5	1/8"-27	150602	DD-432	TS-5.8-10M1	JSLC-HPD4

*8 x Dia. Boring Ratio can be achieved under favorable conditions.

*Right clamp for right hand toolholder. Left clamp for left hand toolholder

E_ADDPN R/L Thru Coolant Jet-Stream™ Carbide Boring Bar Style P- Negative 27.5° end cutting lead angle for negative 55° diamond DN__ inserts

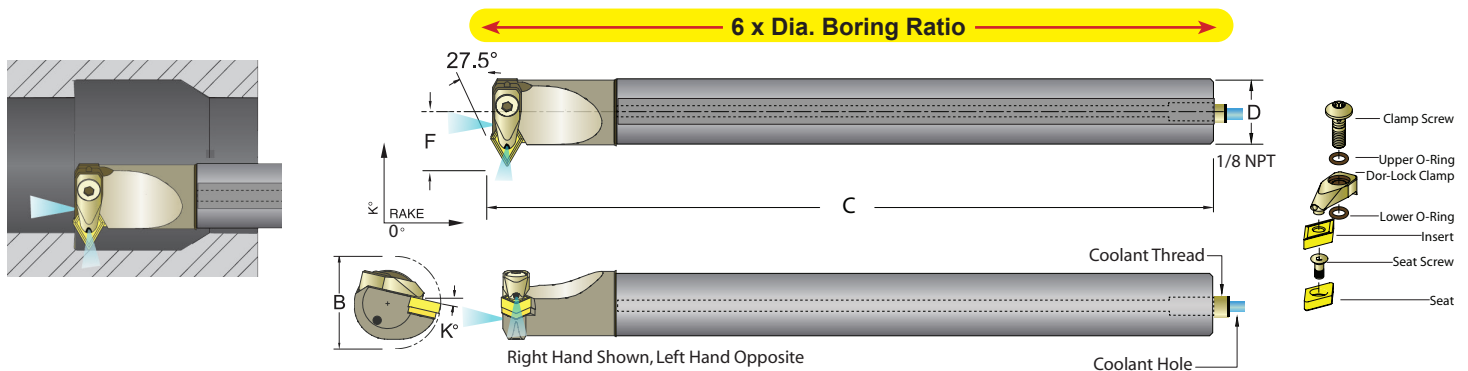

INCH														
Bar Description	UPC No. 733101-		Boring Ratio*	Min. Bore				Coolant Hole	Coolant Thread	DNMG Gage Insert				Dor-Lock Clamp
	R.H.	L.H.		B	C	D	F			K°	Seat	Seat Screw	Seat	
E16R-ADDPNR/L-3	60109	60110	6 x Dia.	1.500	8.000	1.000	0.750	13°	0.197	1/8"-27	332	DD-32.52	TS-35.6-9M1	JSLC-HPDT3-BR/L
E16T-ADDPNR/L-3	60111	60112		1.500	12.00	1.000	0.750	13°	0.197	1/8"-27				
E20U-ADDPNR/L-4	60113	60114		1.750	14.00	1.250	1.000	13°	0.197	1/8"-27	432	DD-432	TS-5.8-10M1	JSLC-HPD4

METRIC														
Bar Description	UPC No. 733101-		Boring Ratio*	Min. Bore				Coolant Hole	Coolant Thread	DNMG Gage Insert				Dor-Lock Clamp
	R.H.	L.H.		B	C	D	F			K°	Seat	Seat Screw	Seat	
E25M-R-ADDPNR/L-11	60115	60116	6 x Dia.	38.1	200	25	19.05	13°	5	1/8"-27	110408	DD-32.52	TS-35.6-9M1	JSLC-HPDT3-BR/L
E25M-T-ADDPNR/L-11	60117	60118		38.1	300	25	19.05	13°	5	1/8"-27				
E32M-U-ADDPNR/L-15	60119	60120		44.5	350	32	25.40	13°	5	1/8"-27	150602	DD-432	TS-5.8-10M1	JSLC-HPD4

*8 x Dia. Boring Ratio can be achieved under favorable conditions.

*Right clamp for right hand toolholder. Left clamp for left hand toolholder

High Performance Carbide Boring Bars

E_ADVUN R/L Thru Coolant Jet-Stream™ Carbide Boring Bar Style U - Negative 3° side cutting lead angle for negative 35° diamond VN__ inserts

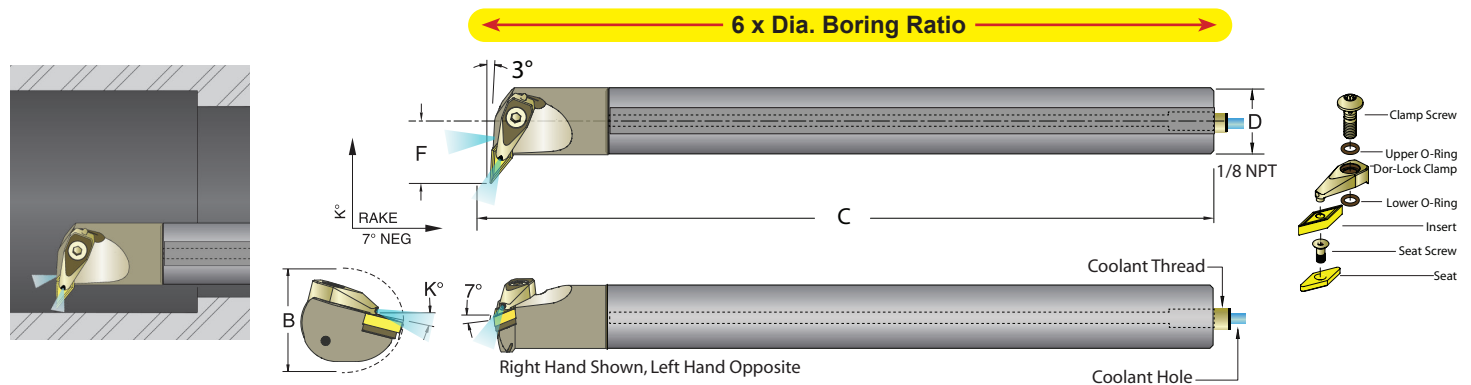

Inch Bar Description	UPC No. 733101-		Boring Ratio*	Min. Bore			F	K°	Coolant Hole	Coolant Thread	VNMG Gage Insert	Seat	Seat Screw	Dor-Lock Clamp
	R.H.	L.H.		B	C	D								
E20U-ADVUNR/L-3	60121	60122	6 x Dia.	2.250	14.00	1.250	1.125	14°	0.197	1/8"-27	332	IVSN-322	SM-M3-V	JSLC-HPV3

Metric Bar Description	UPC No. 733101-		Boring Ratio*	Min. Bore			F	K°	Coolant Hole	Coolant Thread	VNMG Gage Insert	Seat	Seat Screw	Dor-Lock Clamp
	R.H.	L.H.		B	C	D								
E32M-U-ADVUNR/L-16	60123	60124	6 x Dia.	45.0	350	32	28.58	14°	5	1/8"-27	160408	IVSN-322	SM-M3-V	JSLC-HPV3

*8 x Dia. Boring Ratio can be achieved under favorable conditions.

E_ADWLN R/L Thru Coolant Jet-Stream™ Carbide Boring Bar Style L - Negative 5° end & side cutting lead angle for negative 80° trigon WN__ inserts

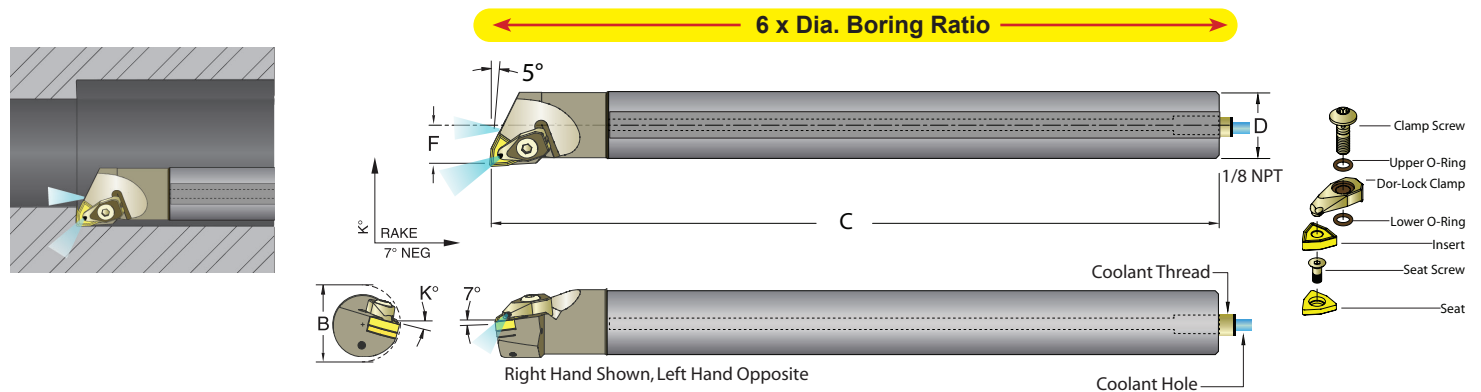

Bar Description	UPC No. 733101-		Boring Ratio*	Min. Bore			F	K°	Coolant Hole	Coolant Thread	WNMG Gage Insert	Seat	Seat Screw	Dor-Lock Clamp
	R.H.	L.H.		B	C	D								
E16R-ADWLN/L-4	60125	60126	6 x Dia.	1.450	8.000	1.000	0.640	14°	0.197	1/8"-27	432	IWSN-433	SM-S4	*JSLC-HPCTW-4R **JSLC-HPCTW-4L
E16T-ADWLN/L-4	60127	60128		1.450	12.00	1.000	0.640	14°	0.197	1/8"-27				
E20U-ADWLN/L-4	60129	60130		1.530	14.00	1.250	0.765	14°	0.197	1/8"-27				

Bar Description	UPC No. 733101-		Boring Ratio*	Min. Bore			F	K°	Coolant Hole	Coolant Thread	WNMG Gage Insert	Seat	Seat Screw	Dor-Lock Clamp
	R.H.	L.H.		B	C	D								
E25M-R-ADWLN/L-08	60131	60132	6 x Dia.	32.5	200	25	16.26	14°	5	1/8"-27	080408	IWSN-433	SM-S4	*JSLC-HPCTW-4R **JSLC-HPCTW-4L
E25M-T-ADWLN/L-08	60133	60134		32.5	300	25	16.26	14°	5	1/8"-27				
E32M-U-ADWLN/L-08	60135	60136		38.9	350	32	19.43	14°	5	1/8"-27				

*8 x Dia. Boring Ratio can be achieved under favorable conditions.

*Right clamp for right hand toolholder. **Left clamp for left hand toolholder

High Performance Carbide Boring Bars

E-ADNE R/L Thru Coolant Jet-Stream™ Carbide Threading Bar Style E- For DorNotch Threading Inserts

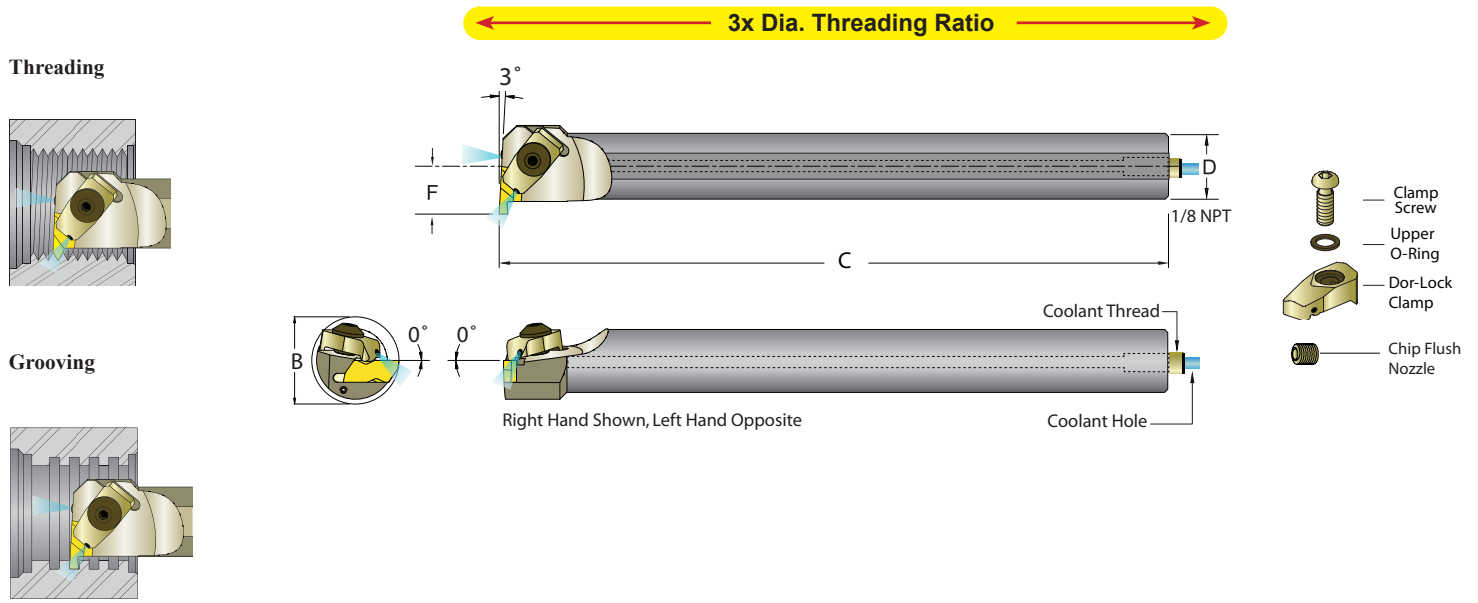

INCH														
Bar Description	UPC No. 733101-R.H.	UPC No. 733101-L.H.	Boring Ratio*	Min. Bore B	C	D	F	Coolant Hole	Coolant Thread	Dor/Notch Gage Insert	Seat	Dor-Lock Clamp	Clamp Screw	Chip Flush Nozzle
E16R-ADNER/L-3	60173	60174	6 x Dia.	1.380	8.000	1.000	0.690	0.197	1/8"-27	NG-3L* NG-3R**	none	JSLC-HP73* JSLC-HP72**	JSCS-04	JSPN-M6
E16T-ADNER/L-3	60175	60176		1.380	12.000	1.000	0.690	0.197	1/8"-27					
E20U-ADNER/L-3	60177	60178		1.750	14.000	1.250	0.880	0.197	1/8"-27					

METRIC														
Bar Description	UPC No. 733101-R.H.	UPC No. 733101-L.H.	Boring Ratio*	Min. Bore B	C	D	F	Coolant Hole	Coolant Thread	Dor/Notch Gage Insert	Seat	Dor-Lock Clamp	Clamp Screw	Chip Flush Nozzle
E25M-R-ADNER/L-3	60183	60184	6 x Dia.	35.1	200	25	17.53	5	1/8"-27	NG-3L* NG-3R**	none	JSLC-HP73* JSLC-HP72**	JSCS-04	JSPN-M6
E25M-T-ADNER/L-3	60185	60186		35.1	300	25	17.53	5	1/8"-27					
E32M-U-ADNER/L-3	60187	60188		44.5	350	32	22.35	5	1/8"-27					

*8 x Dia. Boring Ratio can be achieved under favorable conditions.

* For right hand holder ** For left hand holder

High Performance Carbide Boring Bars

E-ADLN R/L Thru Coolant Jet-Stream™ Carbide Threading Bar Style N-for LayDown Threading Inserts

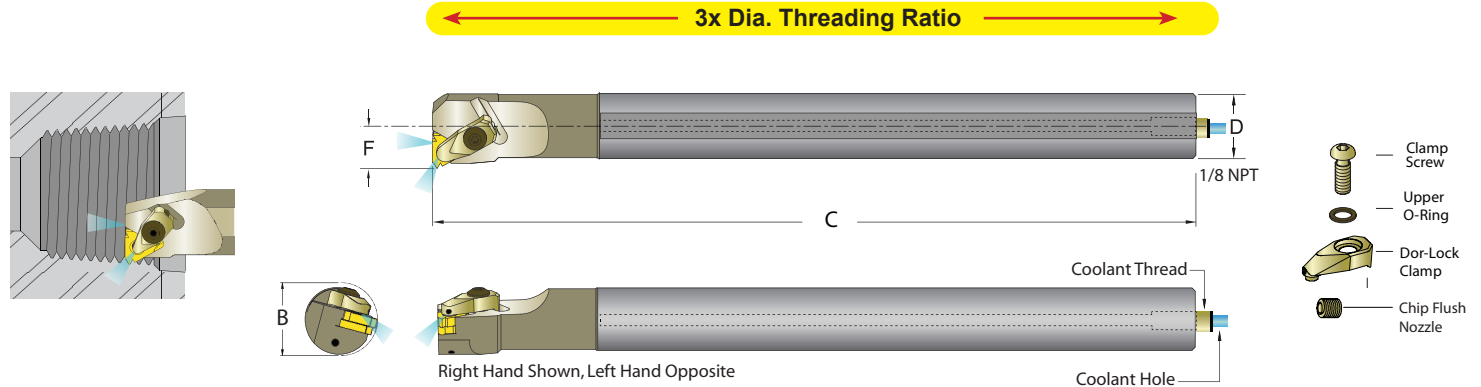

INCH															
Bar Description	UPC No. 733101-		Boring Ratio*	Min. Bore				Coolant Hole	Coolant Thread	LayDown Gage Insert	Seat	Insert or Seat Screw	Dor-Lock Clamp	Clamp Screw	Chip Flush Nozzle
	R.H.	L.H.		B	C	D	F								
E12Q-ADLNR-16	60145	60146	6 x Dia.	1.120	7.000	0.750	0.520	0.157	1/8"-27	16-G60	GXE/I-16	TS-3.5-7M1	JSLC-HP16L* JSLC-HP16R**	JSCS-03	JSPN-M6
E12S-ADLNR-16	60147	60148		1.120	10.00	0.750	0.520	0.157	1/8"-27						
E16R-ADLNR-16	60149	60150		1.375	8.000	1.000	0.650	0.197	1/8"-27						
E16T-ADLNR-16	60151	60152		1.375	12.00	1.000	0.650	0.197	1/8"-27						
E20U-ADLNR-16	60153	60154		1.620	14.00	1.250	0.780	0.197	1/8"-27						
E20U-ADLNR-22	60155	60156		1.750	14.00	1.250	0.840	0.197	1/8"-27	22-N60	NXE/I-22	TS-45.75-15M1	JSLC-HPD4	JSCS-04	JSPN-M6

METRIC															
Bar Description	UPC No. 733101-		Boring Ratio*	Min. Bore				Coolant Hole	Coolant Thread	LayDown Gage Insert	Seat	Insert or Seat Screw	Dor-Lock Clamp	Clamp Screw	Chip Flush Nozzle
	R.H.	L.H.		B	C	D	F								
E20M-Q-ADLNR-16	60157	60158	6 x Dia.	28.4	180	20	13.2	4	1/8"-27	16-G60	GXE/I-16	TS-3.5-7M1	JSLC-HP16L* JSLC-HP16R**	JSCS-03	JSPN-M6
E20M-S-ADLNR-16	60159	60160		28.4	250	20	13.2	4	1/8"-27						
E25M-R-ADLNR-16	60161	60162		34.9	200	25	16.5	5	1/8"-27						
E25M-T-ADLNR-16	60163	60164		34.9	300	25	16.5	5	1/8"-27						
E32M-U-ADLNR-16	60165	60166		41.1	350	32	19.8	5	1/8"-27						
E32M-U-ADLNR-22	60167	60168		44.5	350	32	21.3	5	1/8"-27	22-N60	NXE/I-22	TS-45.75-15M1	JSLC-HPD4	JSCS-04	JSPN-M6

*8 x Dia. Boring Ratio can be achieved under favorable conditions.

* For right hand holder ** For left hand holder

High Performance Quick Change Modular Carbide Boring Bars Body

for Multi Boring and Threading Operation

QUICK - PRECISE - RIGID

Better Machining Performance

Higher Workmanship Quality

Longer Cutting Insert Life

The technology behind the "Quick Change Modular Carbide Boring Bar System"

the rigidity of the carbide boring bar, the interchangeability of the Modular Heads with thru coolant allows a multi boring and threading operation, quick, simple and precise, from heavy roughing to precision finishing, with close tolerance and high surface finish.

- Boring Ratio 6 x Bar Dia.
- Threading Ratio 3 x Bar Dia.

Boring Bar Sizes

Inch: .750" Dia., 1" Dia., 1.250" Dia.

Metric: 20mm Dia., 25mm Dia., 32mm Dia.

Boring Bar Heads

Positive Insert Geometry:

CCGT CPGT DPGT

TCGT TPGT VCGT WCGT

Threading Heads

for Lay-Down Insert:

16-A60 22-N60

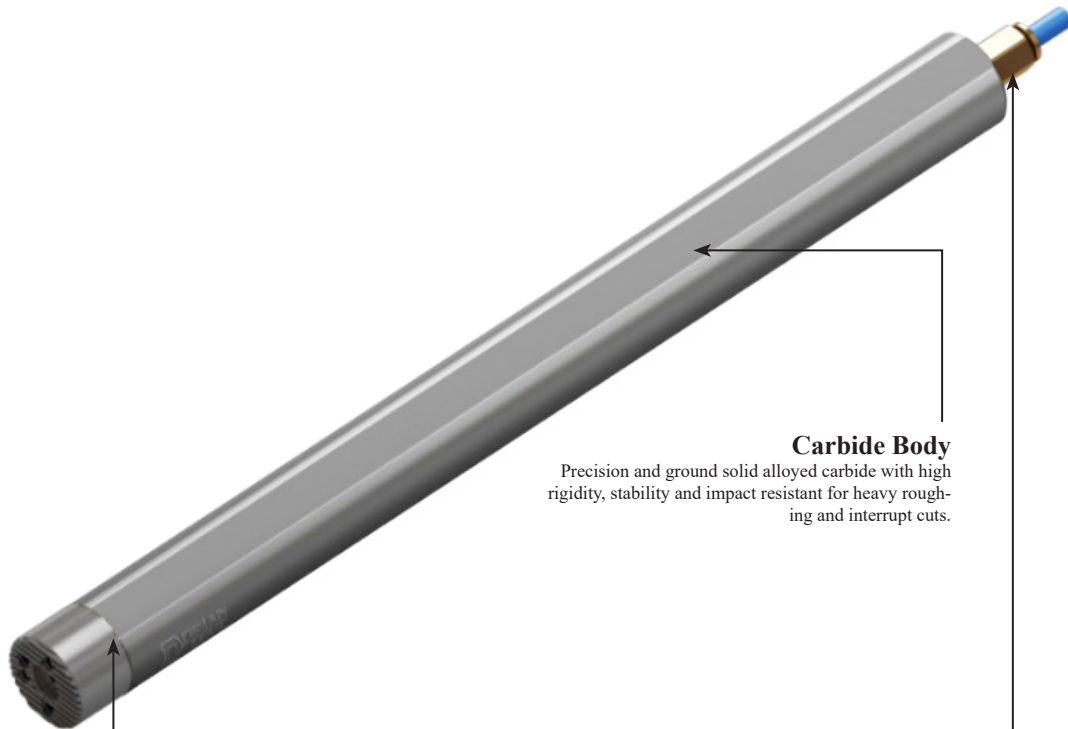

Carbide Body

Precision and ground solid alloyed carbide with high rigidity, stability and impact resistant for heavy roughing and interrupt cuts.

Quick Change Modular Head Collar

Brazed on to the Carbide Bar with triple silver alloys. The combination of the correct alloy and the thickness of the braze makes brazing strong and unbreakable but flexible under cutting pressure and interrupt cuts.

Thru Coolant

Will enhance performance, precision and increase insert life. Chips are removed from the bore, the insert is kept clean and at a constant temperature to minimize cutting edge damage.

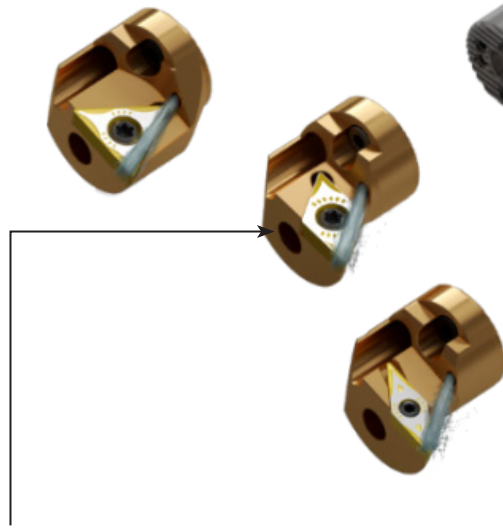

Quick Change Modular Head

Made of heat treated alloy steel TiN coated, locks into Quick Change Modular Head Collar with a 60° serrate grooves to expand surface contact, and locked with 3 cup set screws to for maximum locking rigidity and precise interchangeability.

High Performance Carbide Boring Bars

High Performance Quick Change Modular Carbide Boring Bars Body & Heads

for Multi Boring and Threading Operation

1 SCLC
R/L Quick Change
Boring Bar Head
With Thru Coolant



2 SDNC
R/L Quick Change
Boring Bar Head
With Thru Coolant



3 SDQC
R/L Quick Change
Boring Bar Head
With Thru Coolant



4 SDUC
R/L Quick Change
Boring Bar Head
With Thru Coolant



5 SDXC
R/L Quick Change
Boring Bar Head
With Thru Coolant



6 STUC
R/L Quick Change
Boring Bar Head
With Thru Coolant

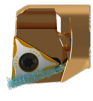

7 SVUC
R/L Quick Change
Boring Bar Head
With Thru Coolant



8 SWLC
R/L Quick Change
Boring Bar Head
With Thru Coolant

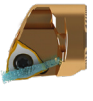

9 SN
R/L Quick Change
Threading Bar Head
With Thru Coolant



One Quick Change Modular
Carbide Body

Nine
Interchangeable Heads

High Performance Carbide Boring Bars

Thru Coolant Quick Change Modular Carbide Boring Bar Body

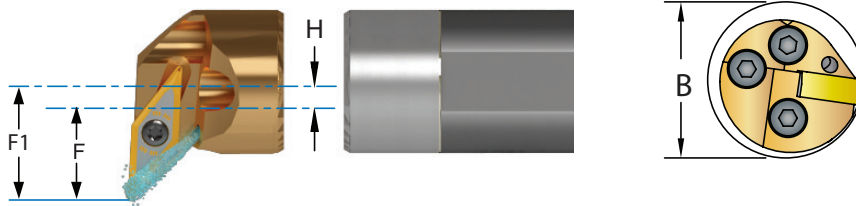
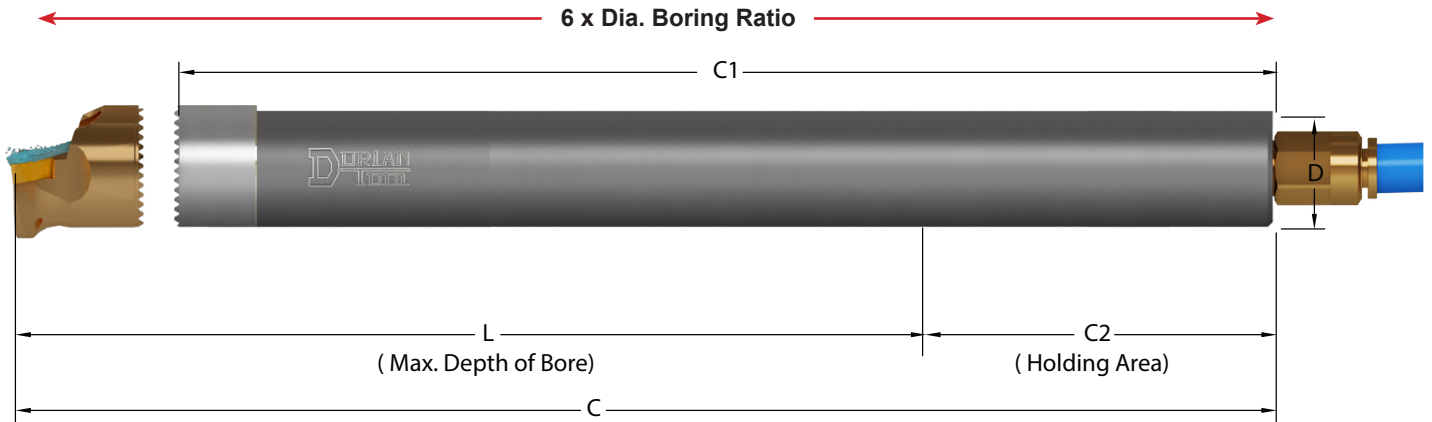

$$F1^* = F + H$$

$$\text{Min Bore} = B + (H \times 2)^*$$

INCH													
Carbide Bar Description	UPC No. 733101- Neutral	Boring Ratio	Carbide Body							Min. Bore B*	Modular Head CBBB	Coolant Bore Dia.	Coolant Attachment Thread
			D	C	C1	L	C2	H	F1*				
AE12I-Q-QCCBB	60195	4x Dia.	0.750	7.000	6.200	4.00	3.00	0	F1=F+H	See head specifications	DBOMH-12/20M	0.157	1/8"-27NTP
AE16I-R-QCCBB	60197		1.000	8.000	7.200	4.00	4.00	0.125				0.197	
AE12I-S-QCCBB	60196		0.750	10.000	9.200	7.00	3.00	0				0.157	
AE16I-T-QCCBB	60198	6x Dia.	1.000	12.00	11.200	8.00	4.00	0.125	F1=F+H	See head specifications	DBOMH-12/20M	0.197	1/8"-27NTP
AE20I-U-QCCBB	60199		1.250	12.80	13.000	8.00	5.00	0.250				0.197	

METRIC													
Carbide Bar Description	UPC No. 733101- Neutral	Boring Ratio	Carbide Body							Min. Bore B*	Modular Head CBBB	Coolant Bore Dia.	Coolant Attachment Thread
			D	C	C1	L	C2	H	F1*				
AE20M-Q-QCCBB	60581	4x Dia.	20	176	156	96	80	0	F1=F+H	See head specifications	DBOMH-12/20M	4	1/8"-27NTP
AE25M-R-QCCBB	60583		25	197	177	97	100	2.5				5	
AE20M-S-QCCBB	60582		20	246	226	166	80	0				4	
AE25M-T-QCCBB	60584	6x Dia.	25	297	277	197	100	2.5	F1=F+H	See head specifications	DBOMH-12/20M	5	1/8"-27NTP
AE32M-U-QCCBB	60585		32	345	325	217	128	6				5	

8 x Dia. Boring Ratio can be achieved under favorable conditions.

High Performance Carbide Boring Bars

SCLC R/L Solution Tool!™ Thru Coolant Quick Change Modular Boring Head Style L- Negative 5° End & Side Cutting Edge Angle for 7° positive 80° diamond CC__ inserts

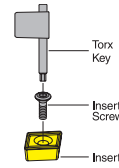
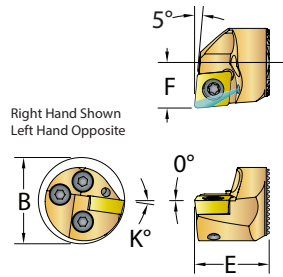
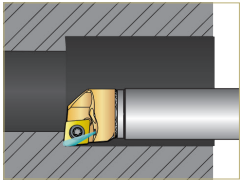

Thru Coolant

Head Description	UPC No. 733101-		B		E		F		K°	Reference Bars Dia.		CCMT Gage Insert		Insert Torx Screw	Torx Key
	R.H.	L.H.	Inch	Metric	Inch	Metric	Inch	Metric		Inch	Metric	Inch	Metric		
	DBOMH-12/20M-SCLCR/L-3	60225	60226	1.000	26	0.820	20.83	0.500		12.70	8°	0.750	20		
			1.250	31	0.820	20.83	0.500	12.70	8°	1.000	25				
			1.500	38	0.820	20.83	0.500	12.70	8°	1.250	32				

Heads will fit both inch and metric boring bar shanks

SDNC R/L Solution Tool!™ Thru Coolant Quick Change Modular Boring Head Style N - Negative 27.5° End & Side Cutting Edge Angle for 7° positive 55° diamond DC__ inserts

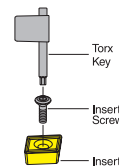
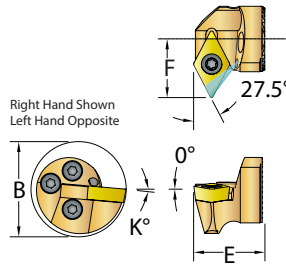
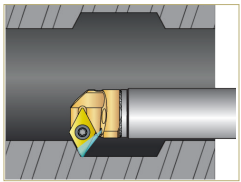

Thru Coolant

Head Description	UPC No. 733101-		B		E		F		K°	Reference Bars Dia.		DCMT Gage Insert		Insert Torx Screw	Torx Key
	R.H.	L.H.	Inch	Metric	Inch	Metric	Inch	Metric		Inch	Metric	Inch	Metric		
	DBOMH-12/20M-SDNCR/L-3	60229	60230	1.160	30	0.820	20.83	0.660		16.76	5°	0.750	20		
			1.410	35	0.820	20.83	0.660	16.76	5°	1.000	25				
			1.660	42	0.820	20.83	0.660	16.76	5°	1.250	32				

Heads will fit both inch and metric boring bar shanks

High Performance Carbide Boring Bars

SDQC R/L Solution Tool!™ Thru Coolant Quick Change Modular Boring Head Style Q - Negative 17.5° End & Side Cutting Edge Angle for 7° positive 55° diamond DC__ inserts

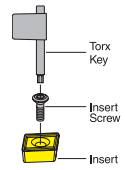
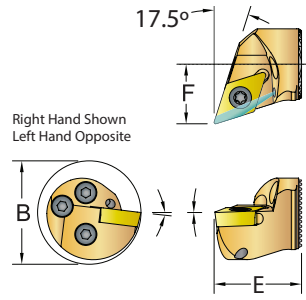
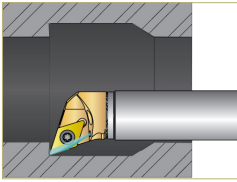

Thru Coolant

Head Description	UPC No. 733101-		B		E		F		K°	Reference Bars Dia.		DCMT Gage Insert		Insert Torx Screw	Torx Key
	R.H.	L.H.	Inch	Metric	Inch	Metric	Inch	Metric		Inch	Metric	Inch	Metric		
	DBOMH-12/20M-SDQCR/L-3	60231	60232	1.125	29	0.820	20.83	0.625		15.88	7°	0.750	20		
			1.375	34	0.820	20.83	0.625	15.88	7°	1.000	25				
			1.625	41	0.820	20.83	0.625	15.88	7°	1.250	32				

Heads will fit both inch and metric boring bar shanks

SDUC R/L Solution Tool!™ Thru Coolant Quick Change Modular Boring Head Style U - Negative 3° End & Side Cutting Edge Angle for 7° positive 55° diamond DC__ inserts

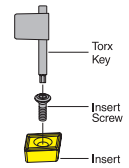
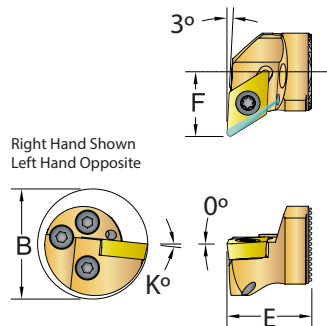
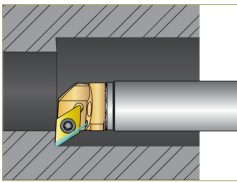

Thru Coolant

Head Description	UPC No. 733101-		B		E		F		K°	Reference Bars Dia.		DCMT Gage Insert		Insert Torx Screw	Torx Key
	R.H.	L.H.	Inch	Metric	Inch	Metric	Inch	Metric		Inch	Metric	Inch	Metric		
	DBOMH-12/20M-SDUCR/L-2	60247	60248	1.025	26	0.820	20.83	0.525		13.34	6°	0.750	20		
			1.275	27	0.820	20.83	0.525	13.34	6°	1.000	25				
			1.525	38	0.820	20.83	0.525	13.34	6°	1.250	32				
DBOMH-12/20M-SDUCR/L-3	60227	60228	1.038	26.37	0.820	20.83	0.625	15.88	6°	0.750	20	32.52	11T308	TS-4.7-10M1	T-15
			1.278	32.46	0.820	20.83	0.745	18.92	6°	1.000	25				
			1.538	39.07	0.820	20.83	0.880	22.35	6°	1.250	32				

Heads will fit both inch and metric boring bar shanks

High Performance Carbide Boring Bars

SDXC R/L Solution Tool!™ Thru Coolant Quick Change Modular Boring Head Style X - Negative 5° Back Boring Cutting Edge Angle for 7° positive 55° diamond DC__ inserts

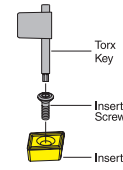
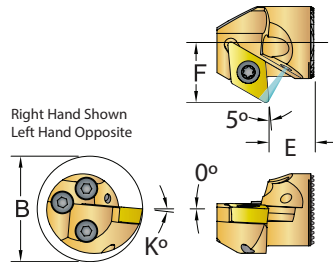
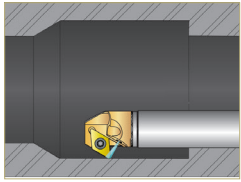

Thru Coolant

Head Description	UPC No. 733101-		B		E		F		K°	Reference Bars Dia.		DCMT Gage Insert		Insert Torx Screw	Torx Key
	R.H.	L.H.	Inch	Metric	Inch	Metric	Inch	Metric		Inch	Metric	Inch	Metric		
	DBOMH-12/20M-SDXCR/L-3	60233	60234	1.025	26	0.820	20.83	0.525		13.34	5°	0.750	20		
			1.275	27	0.820	20.83	0.525	13.34	5°	1.000	25				
			1.525	38	0.820	20.83	0.525	13.34	5°	1.250	32				

Heads will fit both inch and metric boring bar shanks

STUC R/L Solution Tool!™ Thru Coolant Quick Change Modular Boring Head Style U - Negative 3° End Cutting Edge Angle for 7° positive triangle TC__ inserts

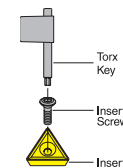
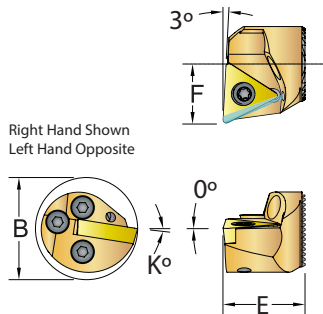
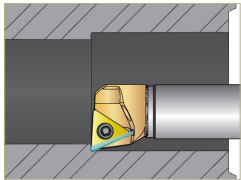

Thru Coolant

Head Description	UPC No. 733101-		B		E		F		K°	Reference Bars Dia.		TCMT Gage Insert		Insert Torx Screw	Torx Key
	R.H.	L.H.	Inch	Metric	Inch	Metric	Inch	Metric		Inch	Metric	Inch	Metric		
	DBOMH-12/20M-STUCR/L-2	60255	60256	1.000	26	0.820	20.83	0.500		12.70	6°	0.750	20		
			1.250	31	0.820	20.83	0.500	12.70	6°	1.000	25				
			1.500	38	0.820	20.83	0.500	12.70	6°	1.250	32				
DBOMH-12/20M-STUCR/L-3	60235	60236	1.090	28	0.820	20.83	0.590	14.99	9°	0.750	20	32.52	16T308	TS-4.7-10M1	T-15
			1.340	33	0.820	20.83	0.590	14.99	9°	1.000	25				
			1.590	40	0.820	20.83	0.590	14.99	9°	1.250	32				

Heads will fit both inch and metric boring bar shanks

High Performance Carbide Boring Bars

SVUC R/L Solution Tool!™ Thru Coolant Quick Change Modular Boring Head Style U - Negative 3° End Cutting Edge Angle for 7° positive 35° diamond VC__ inserts

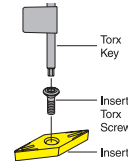
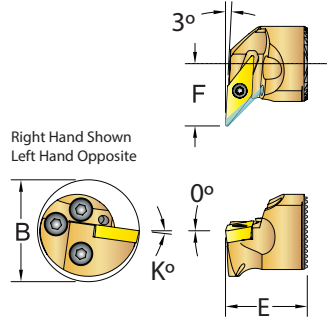
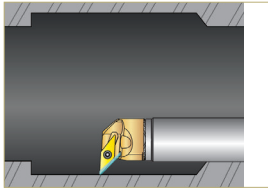

Thru Coolant

Head Description	UPC No. 733101-		B		E		F		K°	Reference Bars Dia.		VCMT Gage Insert		Insert Torx Screw	Torx Key
	R.H.	L.H.	Inch	Metric	Inch	Metric	Inch	Metric		Inch	Metric	Inch	Metric		
	DBOMH-12/20M-SVUCR/L-2	60237	60238	1.125	29	0.820	20.83	0.625		15.88	8°	0.750	20		
			1.375	34	0.820	20.83	0.625	15.88	8°	1.000	25				
			1.625	41	0.820	20.83	0.625	15.88	8°	1.250	32				

Heads will fit both inch and metric boring bar shanks

SWLC R/L Solution Tool!™ Thru Coolant Quick Change Modular Boring Head Style L - Negative 5° End Cutting Edge Angle for 7° positive 80° trigon WC__ inserts

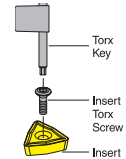
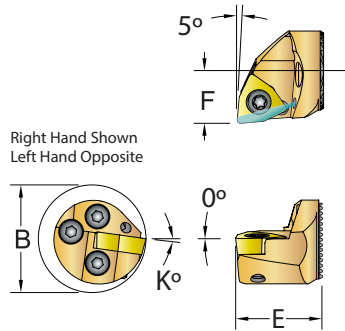
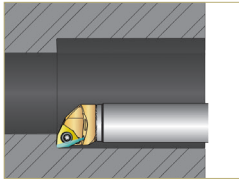

Thru Coolant

Head Description	UPC No. 733101-		B		E		F		K°	Reference Bars Dia.		WCMT Gage Insert		Insert Torx Screw	Torx Key
	R.H.	L.H.	Inch	Metric	Inch	Metric	Inch	Metric		Inch	Metric	Inch	Metric		
	DBOMH-12/20M-SWLCR/L-3	60241	60242	1.000	26	0.820	20.83	0.500		12.70	8°	0.750	20		
			1.250	31	0.820	20.83	0.500	12.70	8°	1.000	25				
			1.500	38	0.820	20.83	0.500	12.70	8°	1.250	32				

Heads will fit both inch and metric boring bar shanks

High Performance Carbide Boring Bars

SN R/L Solution Tool!™ Thru Coolant Quick Change Modular Threading Head for Laydown Inserts

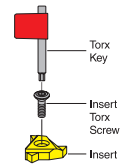
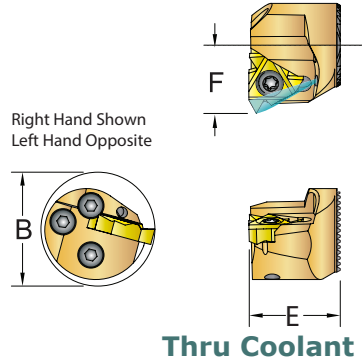
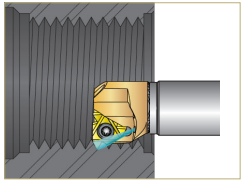

Head Description	UPC No. 733101-		B		E		F		Reference Bars Dia.		Laydown Gage Insert		Insert Torx Screw	Torx Key
	R.H.	L.H.	Inch	Metric	Inch	Metric	Inch	Metric	Inch	Metric	Inch	Metric		
	DBOMH-12/20M-SNR/L-16	60243	60244	1.125	29	0.820	20.83	0.625	15.88	0.750	20	16-A60		
			1.375	34	0.820	20.83	0.625	15.88	1.000	25				
			1.625	41	0.820	20.83	0.625	15.88	1.250	32				

Heads will fit both inch and metric boring bar shanks

Solution Tool!™ The NO! Vibration Tunable Boring Bar

Solution Tool!™

Solutions for Common Deep Hole Boring Problems

Problem	Cause	Solution
Vibrations Surface Finish Chattering	Boring Bar over extended, Incorrect Cutting Ratio, Boring Bar not rigid for the cutting pressure	Do not over extend the Boring Bar above the described cutting ratio; Steel Boring Bar: 4 x Dia. cutting ratio Carbide Boring Bar: 6 x Dia. cutting ratio Solution Tool!™ NO! Vibration Tunable Boring Bar; 8 x Dia., 10 x Dia., 12 x Dia., 14 x Dia.. cutting ratio
	Insert Angle Geometry to large	Reduce the Insert Angle Geometry; 80° Geometry, for roughing application 60° Geometry, for general application 55° Geometry, for finishing application 35° Geometry, for profiling application
	Insert Cutting Radius to Large; to large contact area of the insert with the cutting surface	Reduce the cutting radius until vibration disappears and or increase cutting feed
	Insert Cutting Rake Angle to small; to much cutting pressure	Change to a large cutting rake angle
	Insert Relief Angle to small; cutting pressure pushes the insert down and the bottom will touch the cutting wall, pushing the insert up and down from the center line.	Change to a large relief angle, and place the insert cutting edge above the center line
	Insert Edge Prep. the insert cutting edge has to large of honing surface, this will effect more in small depth of cut and low cutting feed	Change to a sharp cutting edge and or increase cutting feed
	To Low RPM., at low RPM, the cutting edge of the insert moves very slow over the cutting surface, no friction, no heat and little cutting force is developed, resulting a poor and dull surface finish	Increase the RPM
To High RPM. at high RPM, the cutting edge of the insert moves very fast over the cutting surface, generating friction, heat and premature wear of the insert cutting edge, resulting a shine and uneven surface finish	Decrease the RPM	
Not Holding Dimension and Tolerances	Boring Bar Deflection; under the cutting force the boring bar will deflect radially and axially, dimensions and tolerances are difficult to be held	Use a larger diameter boring bar to maximize rigidity & minimize deflection
	Large depth of Cut; with a large depth of cut a lot of cutting force is placed over the boring bar, deflecting radially and axially, and d dimensions and tolerances are difficult to be held	1) Reduce the depth of cut to control and maintain dimensions & tolerances 2) For roughing operation, by trial and error calculate the bar deflection to establish the relation of the finish dimension, boring bar deflection and the depth of cut. 3) For finishing operation, reduce the depth of cut, use an insert with a small angle geometry, and or a small cutting radius and sharp cutting edge.
	Insert Wear; if the insert cutting edge is wearing prematurely, dimensions and tolerances are lost. The RPM is to high and or the insert grade is to soft.	Decrease the RPM and or change to a harder insert grade.
	Insert Cutting Radius to Large; in a small depth of cut a large insert cutting radius will not have enough engagement depth in to cutting surface. The insert will be tearing rather than cutting with a poor surface finish, dimensions and tolerances.	Increase the depth of cut; minimum depth of cut should be not less then 1/2 the size of the insert radius, i.e. .016" (.4mm) depth of cut .008" (.2mm). Increase the depth of cut and or change to a small insert cutting radius.
Whistling Cutting Sound	Insert Cutting Edge Dull Insert Cutting Radius to Large To Small depth of Cut To High RPM	Replace the insert with a harder grade Replace the insert with a smaller cutting radius Increase the depth of cut Change to low RPM
Insert Breaks	RPM to Low Feed Rate to Fast Depth of Cut to Large Insert to Hard	Increase RPM Slow feed rate Change to a small depth of cut Change to a tougher and impact resistant insert
Chattering	Wrong Insert Wrong Boring Bar Wrong Cutting Parameter	The smallest insert angle geometry, high positive with a small cutting radius The largest boring bar possible with shorts overhang The optimum cutting parameter for the specific operation

How to Remove Chattering;

Slow the RPM, cut under the chattered surface, find the correct feed rate for the operation. Resume in normal cutting condition once chatter is removed.

Solution Tool!™

The NO! Vibration Tunable Boring Bar

Makes Deep Hole Boring Simple!

Solution Tool!™ The NO! Vibration Tunable Boring Bar, **will suppress the natural vibration** of the boring bar body, developed when the insert comes in contact with the working piece in the cutting operation. The internally tuned mechanical dampener system provides the optimum dynamic stability in deep hole boring operation, for a Better Machining Performance, Smooth Surface Finish, Precise Tolerance and Long Insert Life.

Solution Tool!™ The NO! Vibration Tunable Boring Bar **will perform where no other types of boring bars, steel or carbide will not perform!**

To maximize performance in deep boring operation, Solution Tool!™ is offered in 2 versions;

Steel Body,

The steel body for boring depth up to 12 x Boring Bar Diameter

Carbide Body,

The carbide body rigidity and stability, allows to bore at higher cutting rate and material removal, and longer depth of cut.



How The Solution Tool!™ The NO! Vibration Tunable Boring Bar Works

The Solution Tool!™ The NO! Vibration Tunable Boring Bar contains a **mechanical floating dampener system dynamically tuned to suppress the natural boring bar vibration** that generates machining chatters. The tuning process establishes the frequency rate per second of the boring bar.

The **mechanical dampener** locate inside the boring bar **housing**, is moved forward or backward until all of the boring bar frequencies are nullified with **zero vibration**. At this point, the **mechanical dampener** is locked in position, restricting the longitudinal movement, but free to move in a radial directions.

In essence, the energy in the Solution Tool!™ is absorbed by the mechanical dampener, and not released to the boring bar in form of vibrations that causes the chatters in the boring operation.

The Solution Tool!™ is dynamically tuned, tested and certified to meet Dorian Tool Quality control standards.

The Solution Tool!™ can be retuned on the machine to optimize the boring bar performance when;

- Extreme and exotic materials change from very soft to very hard.
- Changing the boring depth. Ex: a boring bar with a 12 x Dia. boring Ratio will be used for a shorter boring Ratio like 6 x Dia..
- Improving performance for specific machining operations such as finishing, roughing boring, threading, and grooving.

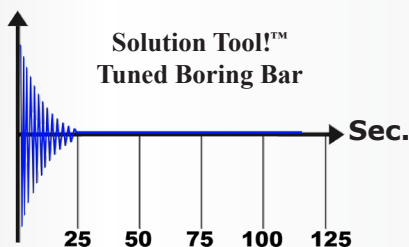
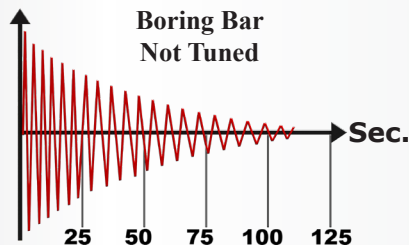

Solution Tool!™ The NO! Vibration Tunable Boring Bar

Solution Tool!™

The NO! Vibration Tunable Boring Bar

Makes Deep Hole Boring Simple!

Solution Tool!™ Integral Bars

The NO! Vibration Tunable Boring Bar

- Carbide Body
- For Small Boring Operation
- Multi Insert Geometry
- Inch and Metric Sizes

Inch, 1/4" Dia., 5/16" Dia., 3/8", 1/2" Dia., 5/8" Dia.

Metric, 6mm, 8mm, 10mm, 12mm, 16mm

- Multi Boring Ratio

8 x Dia., 10 x Dia., 12 x Dia., 14 x Dia.



Solution Tool!™ Quick Change Modular Bars

The NO! Vibration Tunable Boring Bar

- Steel Body
- Carbide Body
- For Medium Boring Operation
- Quick Change Modular Heads with Multi Insert Geometry
- Thru Coolant System
- Inch and Metric Sizes

Inch, 3/4" Dia., 1" Dia., 1 1/4" Dia.

Metric, 20mm, 25mm, 32mm

- Multi Boring Ratio

8 x Dia., 10 x Dia., 12 x Dia., 14 x Dia.

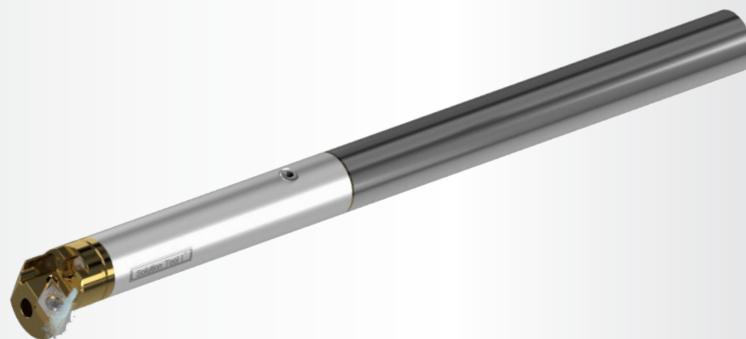

Solution Tool!™ Modular Jet-Stream™ Bars

The NO! Vibration Tunable Boring Bar

- Steel Body
- Carbide Body
- For Large Boring Operation
- Interchangeable Modular Heads with Multi Insert Geometry
- Jet-Stream Thru Coolant System
- Inch and Metric Sizes

Inch, 1 1/2" Dia., 1 3/4" Dia., 2" Dia., 2 1/2" Dia., 3" Dia., 4 Dia.

Metric, 40mm, 50mm, 60mm, 80mm, 100mm.

- Multi Boring Ratio

8 x Dia., 10 x Dia., 12 x Dia., 14 x Dia..

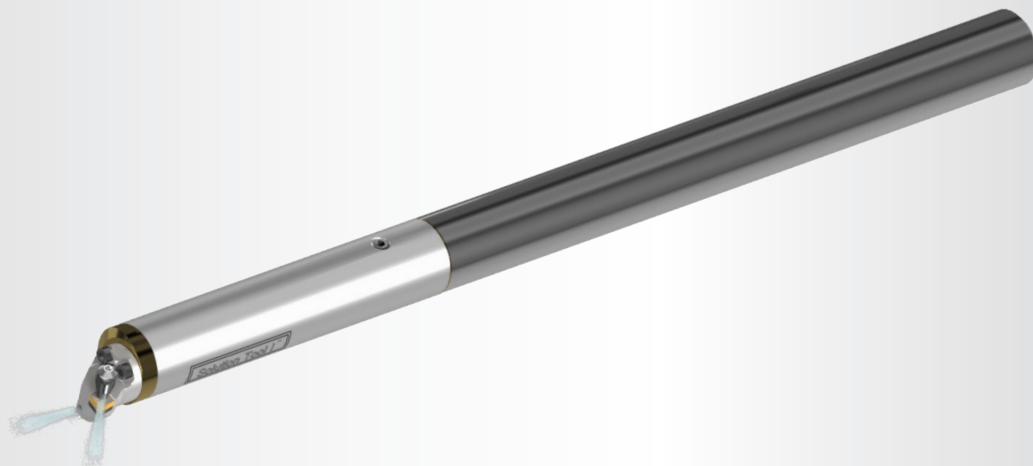

Solution Tool!™

The NO! Vibration Tunable Boring Bar

Makes Deep Hole Boring Simple!

SIMPLE - PRECISE - RIGID

Integral

the NO! Vibration Tunable Boring Bar for Small Boring Operation
Engineered to bore small diameter holes, and cutting depth to 14 x Boring Bar Diameter

Better Machining Performance

Higher Workmanship Quality

Longer Cutting Insert Life

The Technology behind Solution Tool!™ the "Integral" NO! Vibration Tunable Boring Bars, is to perform simple and reliable when deep boring small size holes, with close machining tolerance and high surface finish.

The "Integral" NO! Vibration Tunable Boring Bars, is a two part construction, the body where the boring bar is held, made of alloy carbide for rigidity, stability and strength, holds the dampener, made of heat treated alloy steel, and brazed together with Silver Alloy Braze. **The braze is the buffer zone where the frequencies generate from the cutting operation are stopped.**

Boring Bar Sizes

Inch: 1/4" Dia., 5/16" Dia. 3/8" Dia. 1/2" Dia., 5/8" Dia.

Metric: 6mm Dia., 8mm Dia., 10mm Dia., 12mm Dia., 16mm Dia.

Boring Ratio: 8 x Dia., 10 x Dia., 12 x Dia., 14 x Dia.

Boring Heads

Insert Geometry:
CCMT, CDMT, CPMT
DCMT, TCMT, TPMT

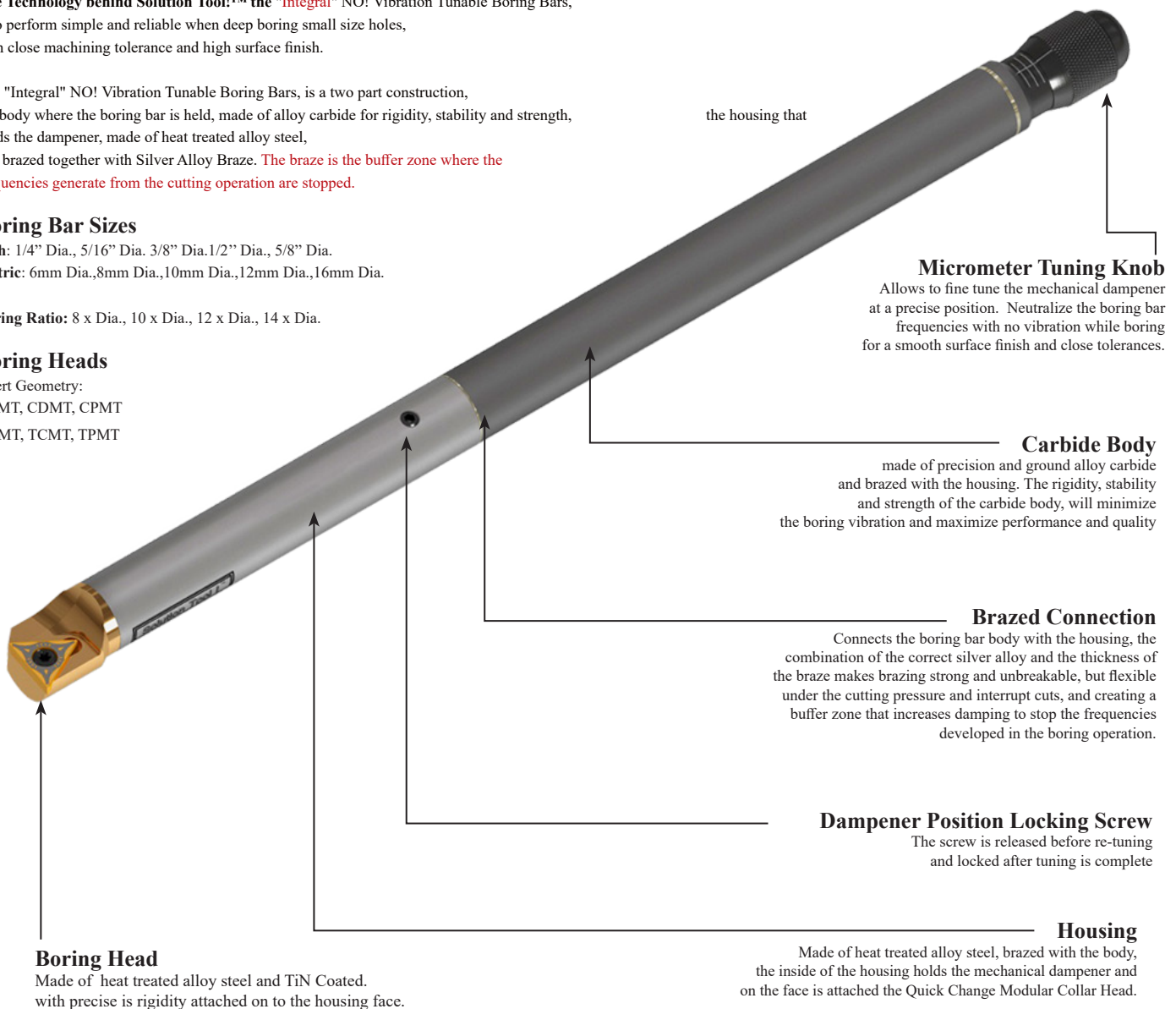

Boring Head

Made of heat treated alloy steel and TIN Coated.
with precise is rigidity attached on to the housing face.

the housing that

Micrometer Tuning Knob

Allows to fine tune the mechanical dampener at a precise position. Neutralize the boring bar frequencies with no vibration while boring for a smooth surface finish and close tolerances.

Carbide Body

made of precision and ground alloy carbide and brazed with the housing. The rigidity, stability and strength of the carbide body, will minimize the boring vibration and maximize performance and quality

Brazed Connection

Connects the boring bar body with the housing, the combination of the correct silver alloy and the thickness of the braze makes brazing strong and unbreakable, but flexible under the cutting pressure and interrupt cuts, and creating a buffer zone that increases damping to stop the frequencies developed in the boring operation.

Dampener Position Locking Screw

The screw is released before re-tuning and locked after tuning is complete

Housing

Made of heat treated alloy steel, brazed with the body, the inside of the housing holds the mechanical dampener and on the face is attached the Quick Change Modular Collar Head.

Solution Tool!™ The NO! Vibration Tunable Boring Bar

SCLC R/L Solution Tool!™ Integral Carbide Boring Bar Style L - Negative 5° End & Side Cutting Edge Angle for 7° positive 80° diamond CC__ inserts

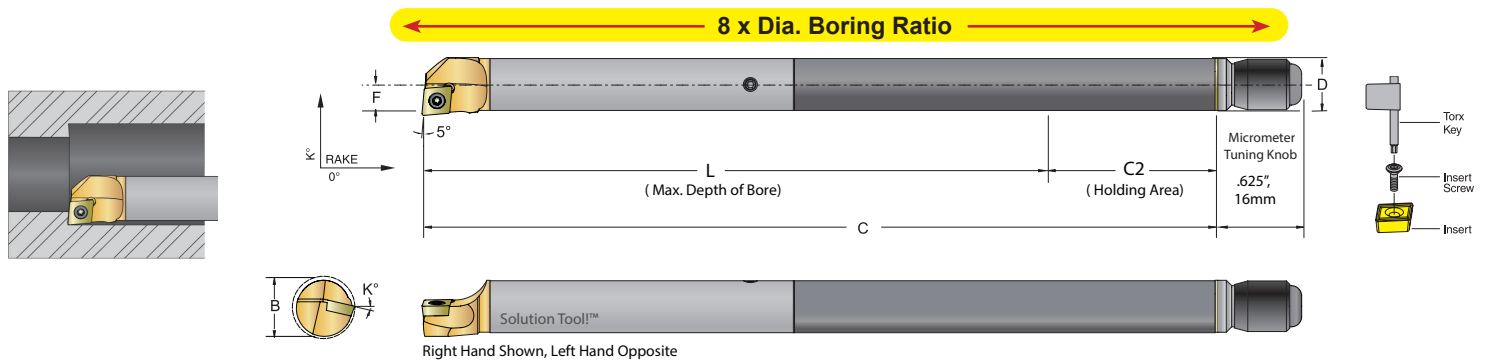

INCH													
Carbide Bar Description	UPC No. 733101-		Boring Ratio	Min. Bore		Carbide Body					CCGW		
	R.H.	L.H.		B	D	C	L	C2	F	K°	Gage Insert	Insert Screw	Torx key
DVI08X-08-SCLCR/L-2-CB	59400	59401	8 x Dia.	.625	0.500	7.00	4.00	3.00	.275	13°	21.51	TS-25-45-6M2	T-8
DVI10X-08-SCLCR/L-2-CB	59402	59403		.781	0.625	8.13	5.00	3.13	.395	10°	21.51	TS-25-45-6M2	T-8
DVI10X-08-SCLCR/L-3-CB	59404	59405		.781	0.625	8.13	5.00	3.13	.395	10°	32.51	TS-4.7-8M1	T-15

METRIC													
Carbide Bar Description	UPC No. 733101-		Boring Ratio	Min. Bore		Carbide Body					CCGW		
	R.H.	L.H.		B	D	C	L	C2	F	K°	Gage Insert	Insert Screw	Torx key
DVM12X-08-SCLCR/L-06-CB	59414	59415	8 x Dia.	14.50	12	168	96	72	6.99	13°	60204	TS-25-45-6M2	T-8
DVM16X-08-SCLCR/L-06-CB	59416	59417		19.50	16	208	128	80	10.03	10°	60204	TS-25-45-6M2	T-8
DVM16X-08-SCLCR/L-09-CB	59418	59419		19.50	16	208	128	80	10.03	10°	09T304	TS-4.7-8M1	T-15

SCLC R/L Solution Tool!™ Integral Carbide Boring Bar Style L - Negative 5° End & Side Cutting Edge Angle for 7° positive 80° diamond CC__ inserts

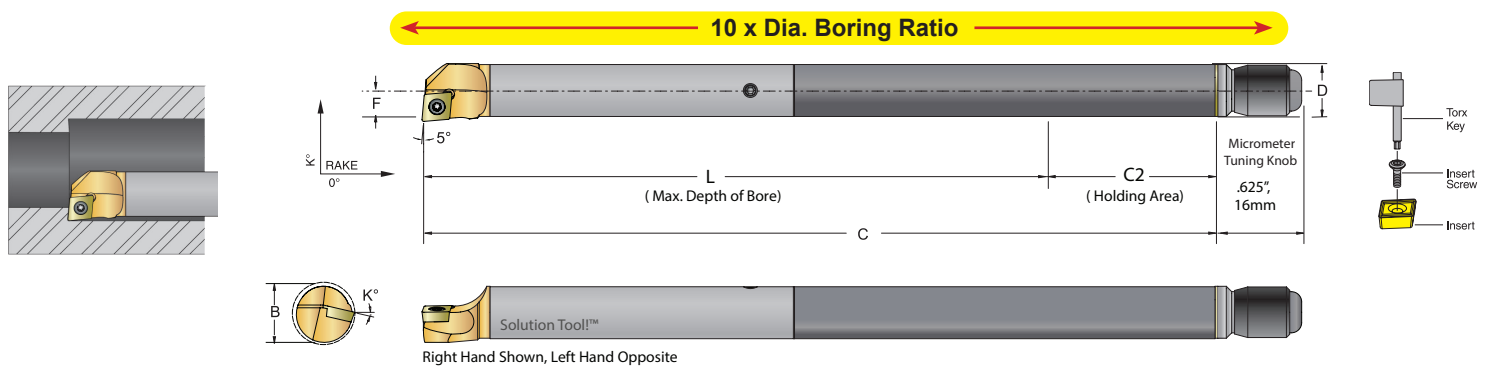

INCH													
Carbide Bar Description	UPC No. 733101-		Boring Ratio	Min. Bore		Carbide Body					CCGW		
	R.H.	L.H.		B	D	C	L	C2	F	K°	Gage Insert	Insert Screw	Torx key
DVI08X-10-SCLCR/L-2-CB	59034	59035	10 x Dia.	.625	0.500	8.00	5.000	3.00	.275	13°	21.51	TS-25-45-6M2	T-8
DVI10X-10-SCLCR/L-2-CB	59040	59041		.781	0.625	9.38	6.25	3.13	.395	10°	21.51	TS-25-45-6M2	T-8
DVI10X-10-SCLCR/L-3-CB	59046	59047		.781	0.625	9.38	6.25	3.13	.395	10°	32.51	TS-4.7-8M1	T-15

METRIC													
Carbide Bar Description	UPC No. 733101-		Boring Ratio	Min. Bore		Carbide Body					CCGW		
	R.H.	L.H.		B	D	C	L	C2	F	K°	Gage Insert	Insert Screw	Torx key
DVM12X-10-SCLCR/L-06-CB	59076	59077	10 x Dia.	14.50	12	192	120	72	6.99	13°	60204	TS-25-45-6M2	T-8
DVM16X-10-SCLCR/L-06-CB	59082	59083		19.50	16	240	160	80	10.03	10°	60204	TS-25-45-6M2	T-8
DVM16X-10-SCLCR/L-09-CB	59088	59089		19.50	16	240	160	80	10.03	10°	09T304	TS-4.7-8M1	T-15

Solution Tool!™ The NO! Vibration Tunable Boring Bar

SCLC R/L Solution Tool!™ Integral Carbide Boring Bar Style L - Negative 5° End & Side Cutting Edge Angle for 7° positive 80° diamond CC__ inserts

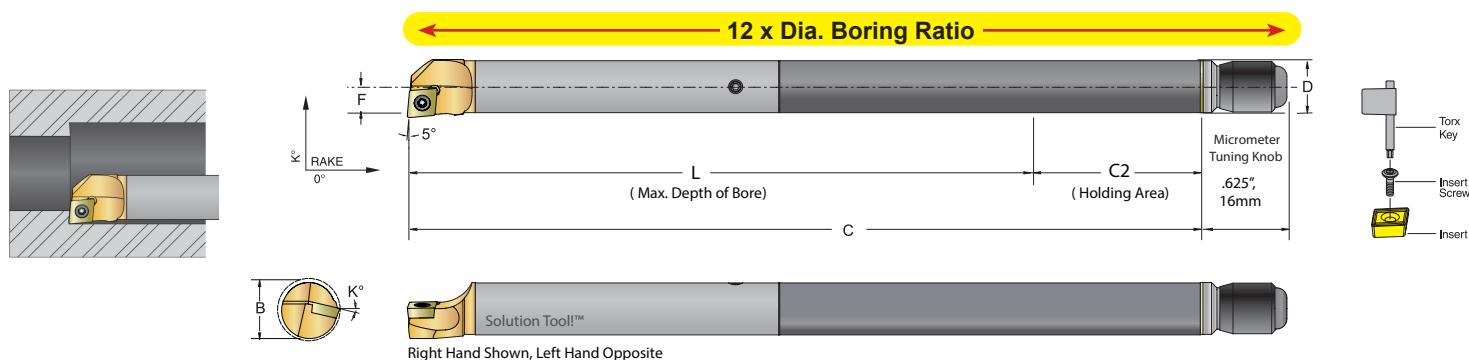

INCH

Carbide Bar Description	UPC No. 733101-		Boring Ratio	Min. Bore			Carbide Body				CCGW		
	R.H.	L.H.		B	D	C	L	C2	F	K°	Gage Insert	Insert Screw	Torx key
DVI08X-12-SCLCR/L-2-CB	59036	59037	12 x Dia.	.625	0.500	9.00	6.00	3.00	.275	13°	21.51	TS-25-45-6M2	T-8
DVI10X-12-SCLCR/L-2-CB	59042	59043		.781	0.625	10.63	7.50	3.13	.395	10°	21.51	TS-25-45-6M2	T-8
DVI10X-12-SCLCR/L-3-CB	59048	59049		.781	0.625	10.63	7.50	3.13	.395	10°	32.51	TS-4-7-8M1	T-15

METRIC

Carbide Bar Description	UPC No. 733101-		Boring Ratio	Min. Bore			Carbide Body				CCGW		
	R.H.	L.H.		B	D	C	L	C2	F	K°	Gage Insert	Insert Screw	Torx key
DVM12X-12-SCLCR/L-06-CB	59078	59079	12 x Dia.	14.50	12	216	144	72	6.99	13°	60204	TS-25-45-6M2	T-8
DVM16X-12-SCLCR/L-06-CB	59084	59085		19.50	16	272	192	80	10.03	10°	60204	TS-25-45-6M2	T-8
DVM16X-12-SCLCR/L-09-CB	59090	59091		19.50	16	272	192	80	10.03	10°	09T304	TS-4-7-8M1	T-15

SCLC R/L Solution Tool!™ Integral Carbide Boring Bar Style L - Negative 5° End & Side Cutting Edge Angle for 7° positive 80° diamond CC__ inserts

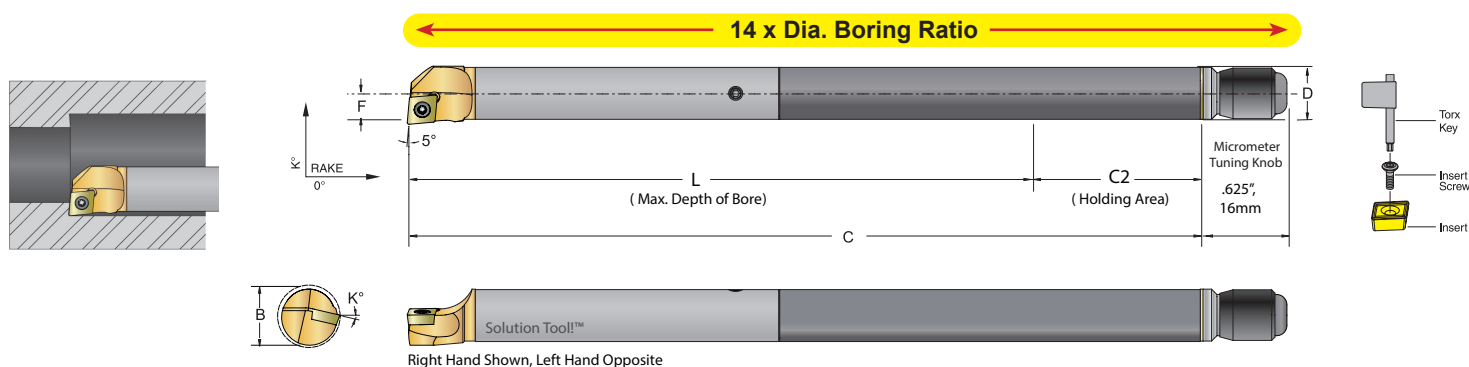

INCH

Carbide Bar Description	UPC No. 733101-		Boring Ratio	Min. Bore			Carbide Body				CCGW		
	R.H.	L.H.		B	D	C	L	C2	F	K°	Gage Insert	Insert Screw	Torx key
DVI08X-14-SCLCR/L-2-CB	59038	59039	14 x Dia.	.625	0.500	10.00	7.000	3.00	.275	13°	21.51	TS-25-45-6M2	T-8
DVI10X-14-SCLCR/L-2-CB	59044	59045		.781	0.625	11.88	8.75	3.13	.395	10°	21.51	TS-25-45-6M2	T-8
DVI10X-14-SCLCR/L-3-CB	59050	59051		.781	0.625	11.88	8.75	3.13	.395	10°	32.51	TS-4-7-8M1	T-15

METRIC

Carbide Bar Description	UPC No. 733101-		Boring Ratio	Min. Bore			Carbide Body				CCGW		
	R.H.	L.H.		B	D	C	L	C2	F	K°	Gage Insert	Insert Screw	Torx key
DVM12X-14-SCLCR/L-06-CB	59080	59081	14 x Dia.	14.50	12	240	168	72	6.99	13°	60204	TS-25-45-6M2	T-8
DVM16X-14-SCLCR/L-06-CB	59086	59087		19.50	16	304	224	80	10.03	10°	60204	TS-25-45-6M2	T-8
DVM16X-14-SCLCR/L-09-CB	59092	59093		19.50	16	304	224	80	10.03	10°	09T304	TS-4-7-8M1	T-15

Solution Tool!™ The NO! Vibration Tunable Boring Bar

SCLD R/L Solution Tool!™ Integral Carbide Boring Bar Style L - Negative 5° End & Side Cutting Edge Angle for 15° positive 80° diamond CD__ inserts

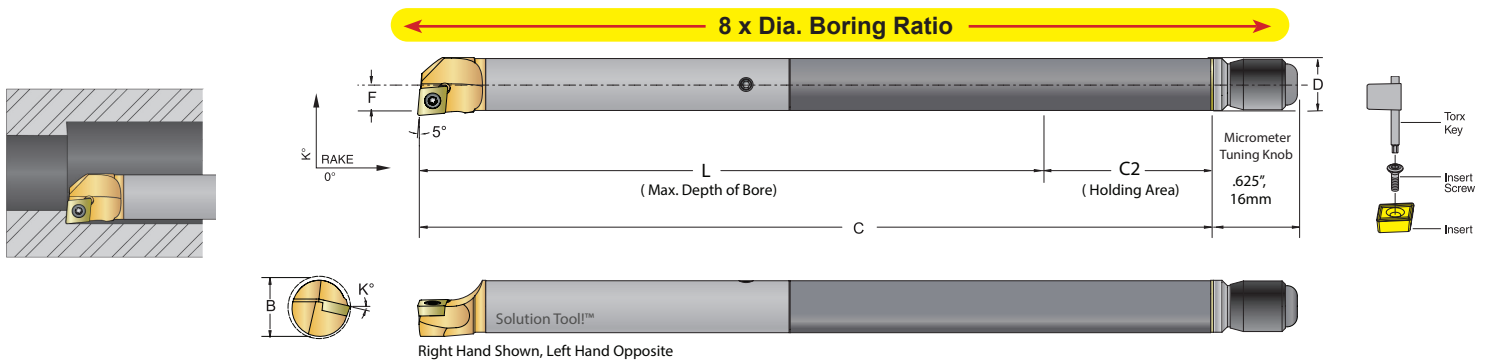

INCH													
Bar Description	UPC No. 733101-R.H.	L.H.	Boring Ratio	Min. Bore			Carbide Body				CDGW		
				B	D	C	L	C2	F	K°	Gage Insert	Insert Screw	Torx key
DVI04X-08-SCLDR/L-1.5-CB	59010	59011	8 x Dia.	.312	0.250	4.000	2.000	2.000	.143	7°	1.510.5	TS-06	T-6
DVI05X-08-SCLDR/L-1.5-CB	59018	59019		.382	0.312	5.00	2.50	2.50	.176	7°			
DVI06X-08-SCLDR/L-1.5-CB	59026	59027		.470	0.375	5.63	3.00	2.63	.220	5°			

METRIC													
Bar Description	UPC No. 733101-R.H.	L.H.	Boring Ratio	Min. Bore			Carbide Body				CDGW		
				B	D	C	L	C2	F	K°	Gage Insert	Insert Screw	Torx key
DVM06X-08-SCLDR/L-04-CB	59052	59053	8 x Dia.	8	6	96.0	48.0	48.0	3.63	7°	40102	TS-06	T-6
DVM08X-08-SCLDR/L-04-CB	59060	59061		10	8	128	64	64	4.47	7°			
DVM10X-08-SCLDR/L-04-CB	59068	59069		12	10	150	80	70	5.59	5°			

SCLD R/L Solution Tool!™ Integral Carbide Boring Bar Style L - Negative 5° End & Side Cutting Edge Angle for 15° positive 80° diamond CD__ inserts

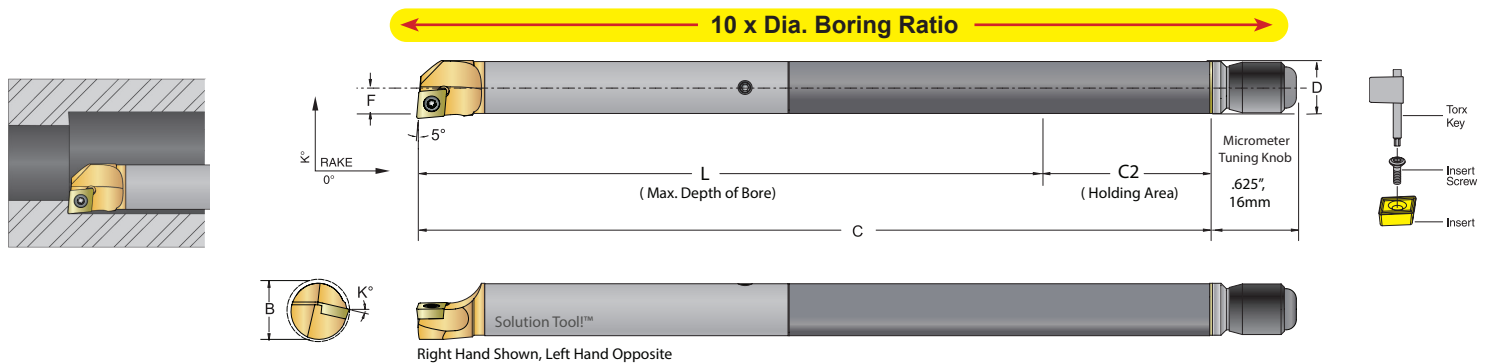

INCH													
Bar Description	UPC No. 733101-R.H.	L.H.	Boring Ratio	Min. Bore			Carbide Body				CDGW		
				B	D	C	L	C2	F	K°	Gage Insert	Insert Screw	Torx key
DVI04X-10-SCLDR/L-1.5-CB	59012	59013	10 x Dia.	.312	0.250	4.50	2.50	2.00	.143	7°	1.510.5	TS-06	T-6
DVI05X-10-SCLDR/L-1.5-CB	59020	59021		.399	0.312	5.62	3.12	2.50	.176	7°			
DVI06X-10-SCLDR/L-1.5-CB	59028	59029		.470	0.375	6.38	3.75	2.63	.220	5°			

METRIC													
Bar Description	UPC No. 733101-R.H.	L.H.	Boring Ratio	Min. Bore			Carbide Body				CDGW		
				B	D	C	L	C2	F	K°	Gage Insert	Insert Screw	Torx key
DVM06X-10-SCLDR/L-04-CB	59054	59055	10 x Dia.	8	6	108	60	48	3.63	7°	40102	TS-06	T-6
DVM08X-10-SCLDR/L-04-CB	59062	59063		10	8	144	80	64	4.47	7°			
DVM10X-10-SCLDR/L-04-CB	59070	59071		12	10	170	100	70	5.59	5°			

Solution Tool!™ The NO! Vibration Tunable Boring Bar

SCLD R/L Solution Tool!™ Integral Carbide Boring Bar Style L - Negative 5° End & Side Cutting Edge Angle for 15° positive 80° diamond CD__ inserts

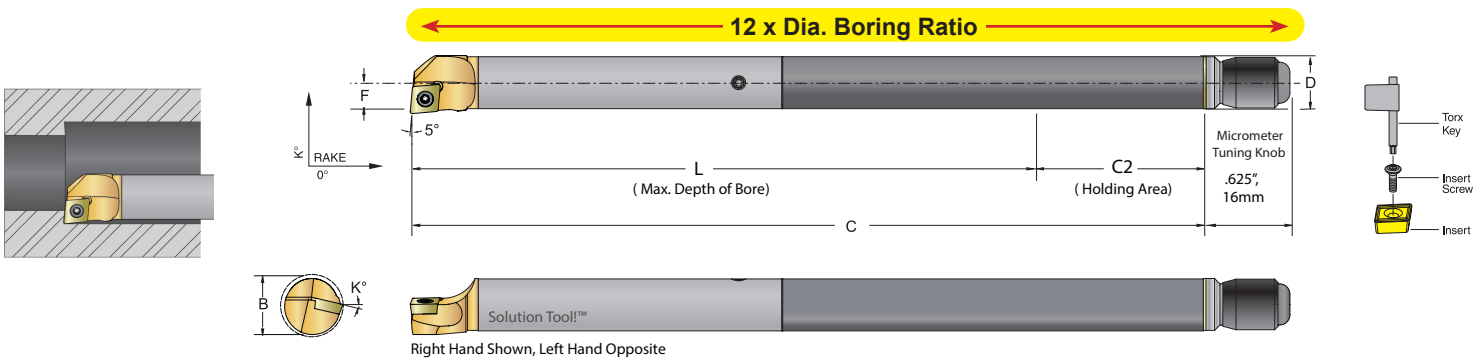

INCH

Bar Description	UPC No. 733101-R.H.	L.H.	Boring Ratio	Min. Bore			Carbide Body			K°	CDGW		
				B	D	C	L	C2	F		Gage Insert	Insert Screw	Torx key
DVI04X-12-SCLDR/L-1.5-CB	59014	59015	12 x Dia.	.312	0.250	5.000	3.000	2.000	.143	7°	1.510.5	TS-06	T-6
DVI05X-12-SCLDR/L-1.5-CB	59022	59023		.399	0.312	6.24	3.74	2.50	.176	7°			
DVI06X-12-SCLDR/L-1.5-CB	59030	59031		.470	0.375	7.13	4.50	2.63	.220	5°			

METRIC

Bar Description	UPC No. 733101-R.H.	L.H.	Boring Ratio	Min. Bore			Carbide Body			K°	CDGW		
				B	D	C	L	C2	F		Gage Insert	Insert Screw	Torx key
DVM06X-12-SCLDR/L-04-CB	59056	59057	12 x Dia.	8	6	120	72	48	3.63	7°	40102	TS-06	T-6
DVM08X-12-SCLDR/L-04-CB	59064	59065		10	8	160	96	64	4.47	7°			
DVM10X-12-SCLDR/L-04-CB	59072	59073		12	10	190	120	70	5.59	5°			

SCLD R/L Solution Tool!™ Integral Carbide Boring Bar Style L - Negative 5° End & Side Cutting Edge Angle for 7° positive 80° diamond CD__ inserts

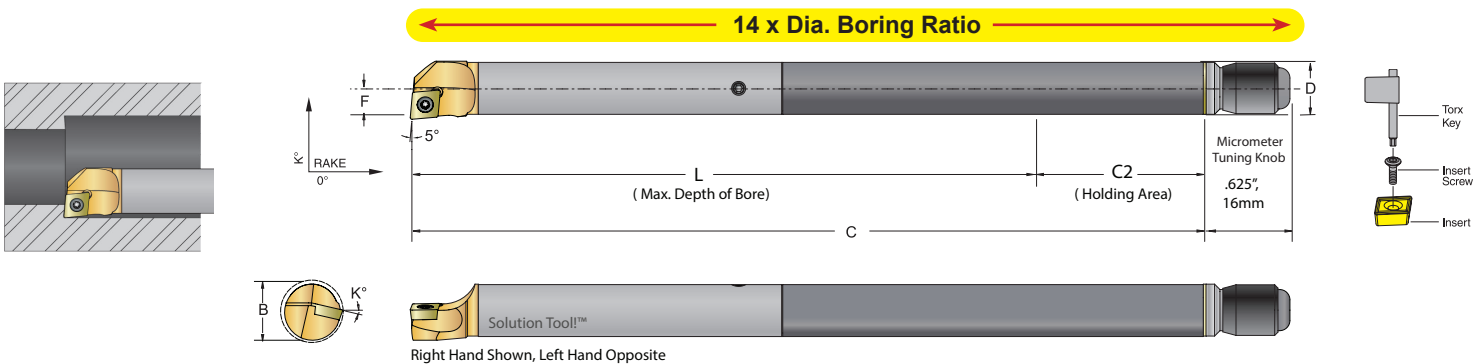

INCH

Bar Description	UPC No. 733101-R.H.	L.H.	Boring Ratio	Min. Bore			Carbide Body			K°	CDGW		
				B	D	C	L	C2	F		Gage Insert	Insert Screw	Torx key
DVI04X-14-SCLDR/L-1.5-CB	59016	59017	14 x Dia.	.312	0.250	5.50	3.50	2.00	.143	7°	1.510.5	TS-06	T-6
DVI05X-14-SCLDR/L-1.5-CB	59024	59025		.399	0.312	6.87	4.37	2.50	.176	7°			
DVI06X-14-SCLDR/L-1.5-CB	59032	59033		.470	0.375	7.88	5.25	2.63	.220	5°			

METRIC

Bar Description	UPC No. 733101-R.H.	L.H.	Boring Ratio	Min. Bore			Carbide Body			K°	CDGW		
				B	D	C	L	C2	F		Gage Insert	Insert Screw	Torx key
DVM06X-14-SCLDR/L-04-CB	59058	59059	14 x Dia.	8	6	132	84	48	3.63	7°	40102	TS-06	T-6
DVM08X-14-SCLDR/L-04-CB	59066	59067		10	8	176	112	64	4.47	7°			
DVM10X-14-SCLDR/L-04-CB	59074	59075		12	10	210	140	70	5.59	5°			

Solution Tool!™ The NO! Vibration Tunable Boring Bar

SCLP R/L Solution Tool!™ Integral Carbide Boring Bar Style L - Negative 5° End & Side Cutting Edge Angle for 110° positive 80° diamond CP__ inserts

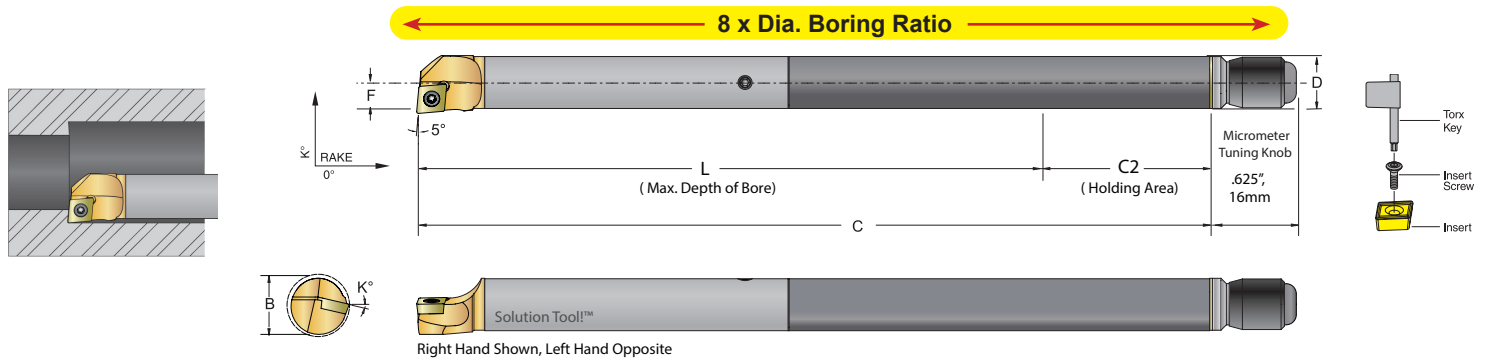

INCH													
Carbide Bar Description	UPC No. 733101-		Boring Ratio	Min. Bore		Carbide Body					CPGW		
	R.H.	L.H.		B	D	C	L	C2	F	K°	Gage Insert	Insert Screw	Torx key
DVI08X-08-SCLPR/L-2-CB	60301	60302	8 x Dia.	.625	0.500	7.00	4.00	3.00	0.275	3°	21.51	TS-25-45-6M2	T-8
DVI10X-08-SCLPR/L-2-CB	60309	60310		.750	0.625	8.13	5.00	3.13	0.395	2°	21.51	TS-25-45-6M2	T-8
DVI10X-08-SCLPR/L-3-CB	60317	60318		.750	0.625	8.13	5.00	3.13	0.395	2°	32.51	TS-4.7-8M1	T-15

METRIC													
Carbide Bar Description	UPC No. 733101-		Boring Ratio	Min. Bore		Carbide Body					CPGW		
	R.H.	L.H.		B	D	C	L	C2	F	K°	Gage Insert	Insert Screw	Torx key
DVM12X-08-SCLPR/L-06-CB	60325	60326	8 x Dia.	15	12	168	96	72	6.99	3°	60204	TS-25-45-6M2	T-8
DVM16X-08-SCLPR/L-06-CB	60333	60334		20	16	208	128	80	10.03	2°	60204	TS-25-45-6M2	T-8
DVM16X-08-SCLPR/L-09-CB	60341	60342		20	16	208	128	80	10.03	2°	09T304	TS-4.7-8M1	T-15

SCLP R/L Solution Tool!™ Integral Carbide Boring Bar Style L - Negative 5° End & Side Cutting Edge Angle for 7° positive 80° diamond CP__ inserts

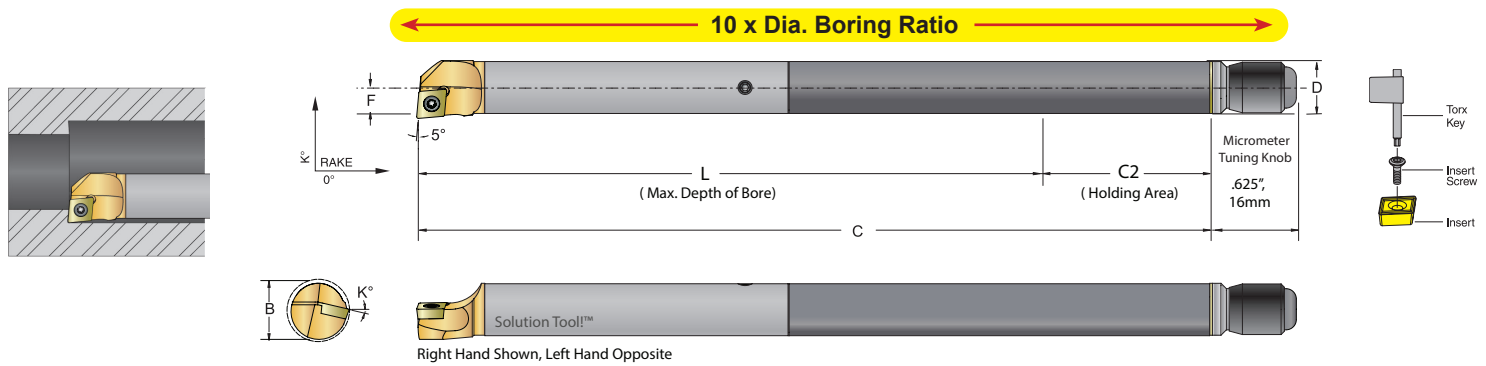

INCH													
Carbide Bar Description	UPC No. 733101-		Boring Ratio	Min. Bore		Carbide Body					CPGW		
	R.H.	L.H.		B	D	C	L	C2	F	K°	Gage Insert	Insert Screw	Torx key
DVI08X-10-SCLPR/L-2-CB	60303	60304	10 x Dia.	.625	0.500	8.00	5.00	3.00	0.275	3°	21.51	TS-25-45-6M2	T-8
DVI10X-10-SCLPR/L-2-CB	60311	60312		.750	0.625	9.38	6.25	3.13	0.395	2°	21.51	TS-25-45-6M2	T-8
DVI10X-10-SCLPR/L-3-CB	60319	60320		.750	0.625	9.38	6.25	3.13	0.395	2°	32.51	TS-4.7-8M1	T-15

METRIC													
Carbide Bar Description	UPC No. 733101-		Boring Ratio	Min. Bore		Carbide Body					CPGW		
	R.H.	L.H.		B	D	C	L	C2	F	K°	Gage Insert	Insert Screw	Torx key
DVM12X-10-SCLPR/L-06-CB	60327	60328	10 x Dia.	15	12	192	120	72	6.99	3°	60204	TS-25-45-6M2	T-8
DVM16X-10-SCLPR/L-06-CB	60335	60336		20	16	240	160	80	10.03	2°	60204	TS-25-45-6M2	T-8
DVM16X-10-SCLPR/L-09-CB	60343	60344		20	16	240	160	80	10.03	2°	09T304	TS-4.7-8M1	T-15

Solution Tool!™ The NO! Vibration Tunable Boring Bar

SCLP R/L Solution Tool!™ Integral Carbide Boring Bar Style L - Negative 5° End & Side Cutting Edge Angle for 110° positive 80° diamond CP__ inserts

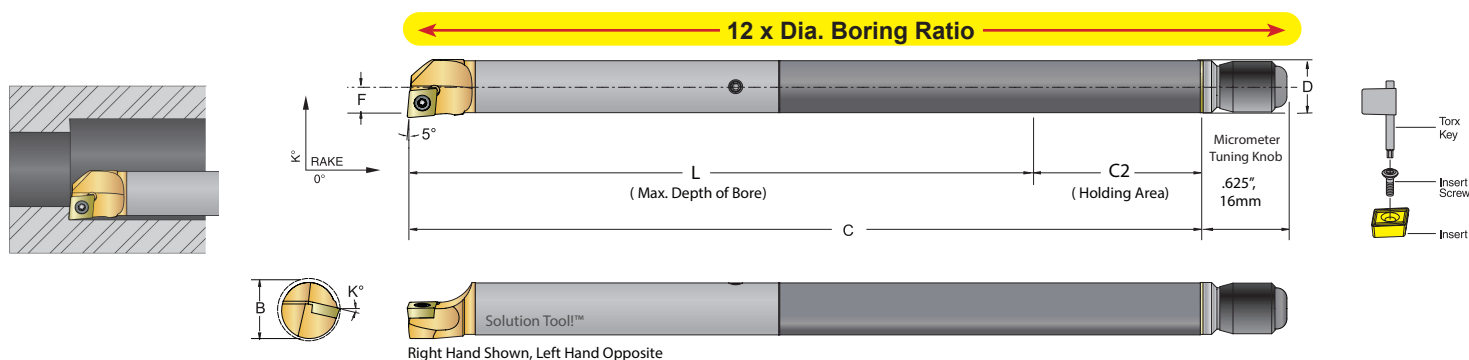

INCH													
Carbide Bar Description	UPC No. 733101-		Boring Ratio	Min. Bore			Carbide Body				CCGW		
	R.H.	L.H.		B	D	C	L	C2	F	K°	Gage Insert	Insert Screw	Torx key
DVI08X-12-SCLPR/L-2-CB	60305	60306	12 x Dia.	.625	0.500	9.00	6.00	3.00	0.275	3°	21.51	TS-25-45-6M2	T-8
DVI10X-12-SCLPR/L-2-CB	60313	60314		.750	0.625	10.63	7.50	3.13	0.395	2°	21.51	TS-25-45-6M2	T-8
DVI10X-12-SCLPR/L-3-CB	60321	60322		.750	0.625	10.63	7.50	3.13	0.395	2°	32.51	TS-4.7-8M1	T-15

METRIC													
Carbide Bar Description	UPC No. 733101-		Boring Ratio	Min. Bore			Carbide Body				CPGW		
	R.H.	L.H.		B	D	C	L	C2	F	K°	Gage Insert	Insert Screw	Torx key
DVM12X-12-SCLPR/L-06-CB	60329	60330	12 x Dia.	15	12	216	144	72	6.99	3°	60204	TS-25-45-6M2	T-8
DVM16X-12-SCLPR/L-06-CB	60337	60338		20	16	272	192	80	10.03	2°	60204	TS-25-45-6M2	T-8
DVM16X-12-SCLPR/L-09-CB	60345	60346		20	16	272	192	80	10.03	2°	09T304	TS-4.7-8M1	T-15

SCLP R/L Solution Tool!™ Integral Carbide Boring Bar Style L - Negative 5° End & Side Cutting Edge Angle for 7° positive 80° diamond CP__ inserts

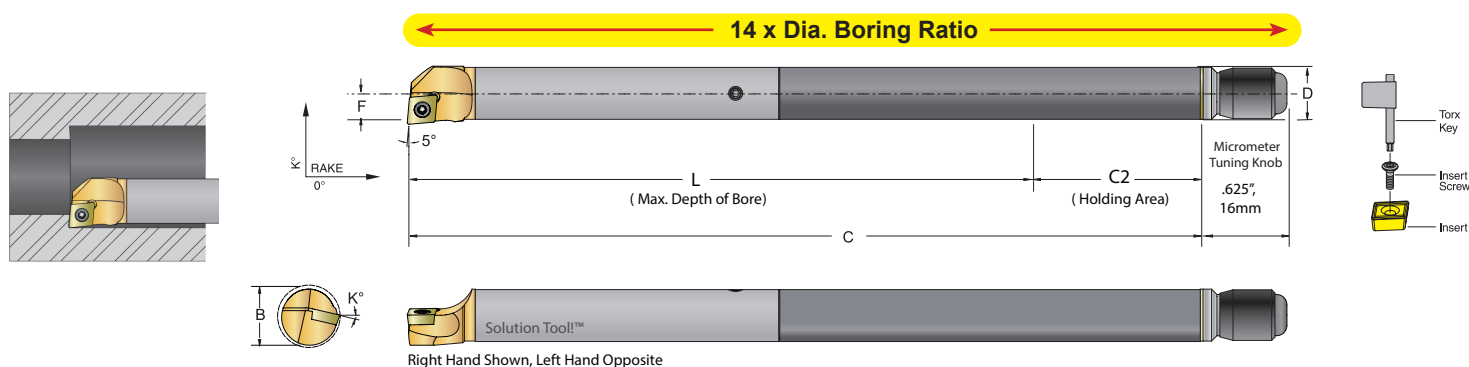

INCH													
Carbide Bar Description	UPC No. 733101-		Boring Ratio	Min. Bore			Carbide Body				CPGW		
	R.H.	L.H.		B	D	C	L	C2	F	K°	Gage Insert	Insert Screw	Torx key
DVI08X-14-SCLPR/L-2-CB	60307	60308	14 x Dia.	.625	0.500	10.00	7.00	3.00	0.275	3°	21.51	TS-25-45-6M2	T-8
DVI12X-14-SCLPR/L-2-CB	60315	60316		.750	0.625	11.88	8.75	3.13	0.395	2°	21.51	TS-25-45-6M2	T-8
DVI12X-14-SCLPR/L-3-CB	60323	60324		.750	0.625	11.88	8.75	3.13	0.395	2°	32.51	TS-4.7-8M1	T-15

METRIC													
Carbide Bar Description	UPC No. 733101-		Boring Ratio	Min. Bore			Carbide Body				CPGW		
	R.H.	L.H.		B	D	C	L	C2	F	K°	Gage Insert	Insert Screw	Torx key
DVM12X-14-SCLPR/L-06-CB	60331	60332	14 x Dia.	15	12	240	168	72	6.99	3°	60204	TS-25-45-6M2	T-8
DVM16X-14-SCLPR/L-06-CB	60339	60340		20	16	304	224	80	10.03	2°	60204	TS-25-45-6M2	T-8
DVM16X-14-SCLPR/L-09-CB	60347	60348		20	16	304	224	80	10.03	2°	09T304	TS-4.7-8M1	T-15

Solution Tool!™ The NO! Vibration Tunable Boring Bar

SDUC R/L Solution Tool!™ Integral Carbide Boring Bar Style U - Negative 3° End Cutting Edge Angle for 7° positive 55° diamond DC__ inserts

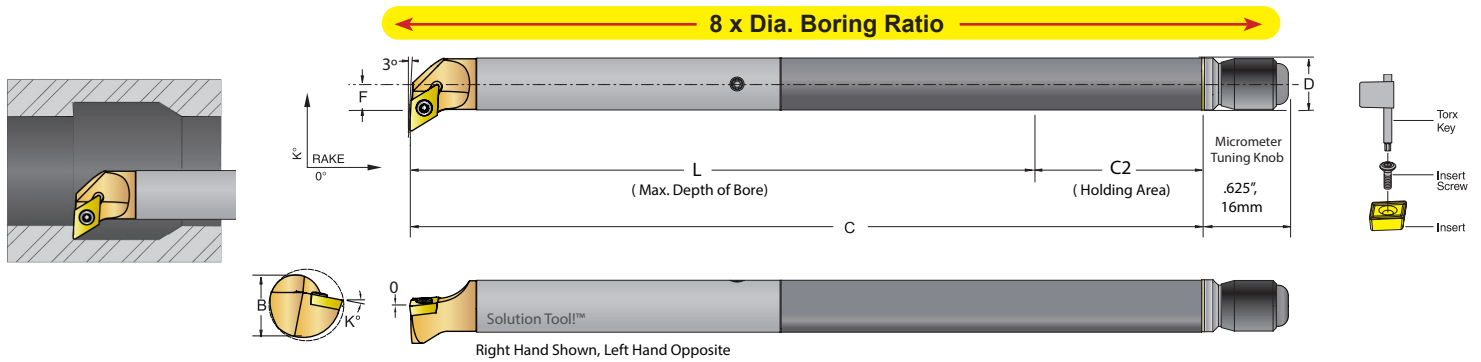

INCH													
Carbide Bar Description	UPC No. 733101-		Boring Ratio	Min. Bore B	Carbide Body					DCGW			
	R.H.	L.H.			D	C	L	C2	F	K°	Gage Insert	Insert Screw	Torx key
DVI06X-08-SDUCR/L-2-CB	59142	59143	8 x Dia.	.625	0.375	5.63	3.00	2.63	0.375	11°	21.51	TS-25-45-6M2	T-8
DVI08X-08-SDUCR/L-2-CB	59406	59407		.750	0.500	7.00	4.00	3.00	0.437	11°			
DVI10X-08-SDUCR/L-2-CB	59408	59409		.875	0.625	8.13	5.00	3.13	0.500	7°			

METRIC													
Carbide Bar Description	UPC No. 733101-		Boring Ratio	Min. Bore B	Carbide Body					DCGW			
	R.H.	L.H.			D	C	L	C2	F	K°	Gage Insert	Insert Screw	Torx key
DVM10X-08-SDUCR/L-07-CB	59162	59163	8 x Dia.	16	10	150	80	70	9.53	11°	070204	TS-25-45-6M2	T-8
DVM12X-08-SDUCR/L-07-CB	59420	59421		19	12	168	96	72	11.10	11°			
DVM16X-08-SDUCR/L-07-CB	59422	59423		22	16	208	128	80	12.70	7°			

SDUC R/L Solution Tool!™ Integral Carbide Boring Bar Style U - Negative 3° End Cutting Edge Angle for 7° positive 55° diamond DC__ inserts

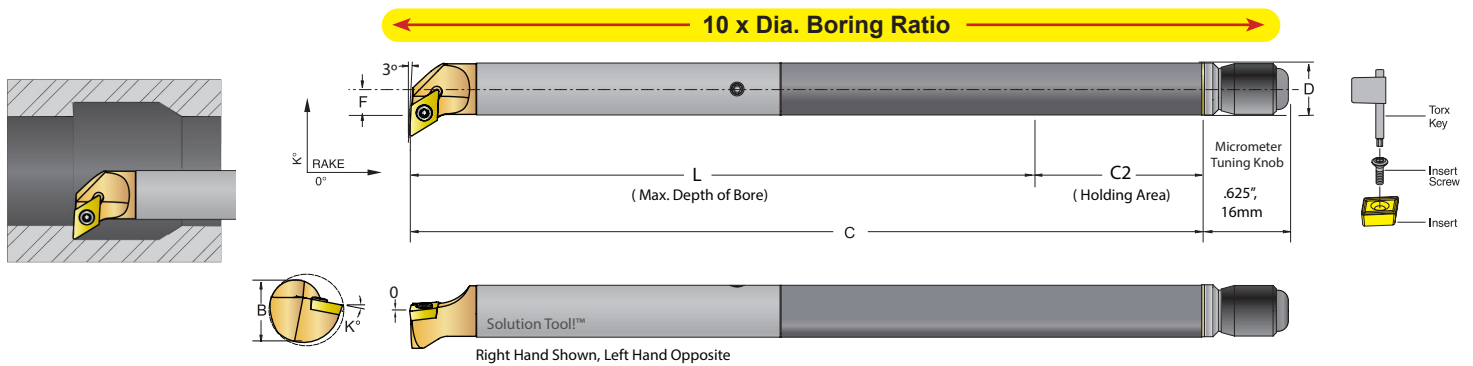

METRIC													
Carbide Bar Description	UPC No. 733101-		Boring Ratio	Min. Bore B	Carbide Body					DCGW			
	R.H.	L.H.			D	C	L	C2	F	K°	Gage Insert	Insert Screw	Torx key
DVI06X-10-SDUCR/L-2-CB	59144	59145	10 x Dia.	.625	0.375	6.38	3.75	2.63	0.375	11°	21.51	TS-25-45-6M2	T-8
DVI08X-10-SDUCR/L-2-CB	59150	59151		.750	0.500	8.00	5.00	3.00	0.437	11°			
DVI10X-10-SDUCR/L-2-CB	60297	60298		.875	0.625	9.38	6.25	3.13	0.500	7°			

INCH													
Carbide Bar Description	UPC No. 733101-		Boring Ratio	Min. Bore B	Carbide Body					DCGW			
	R.H.	L.H.			D	C	L	C2	F	K°	Gage Insert	Insert Screw	Torx key
DVM10X-10-SDUCR/L-07-CB	59170	59171	10 x Dia.	16	10	170	100	70	9.53	11°	070204	TS-25-45-6M2	T-8
DVM12X-10-SDUCR/L-07-CB	59164	59165		19	12	192	120	72	11.10	11°			
DVM16X-10-SDUCR/L-07-CB	59176	59177		22	16	240	160	80	12.70	7°			

Solution Tool!™ The NO! Vibration Tunable Boring Bar

SDUC R/L Solution Tool!™ Integral Carbide Boring Bar Style U - Negative 3° End Cutting Edge Angle for 7° positive 55° diamond DC__ inserts

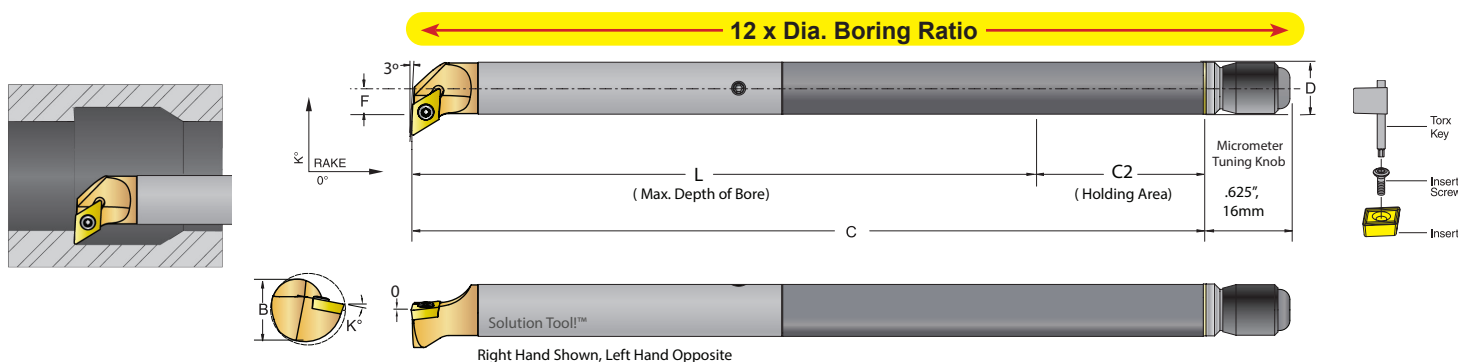

INCH													
Carbide Bar Description	UPC No. 733101-		Boring Ratio	Min. Bore			Carbide Body			K°	DCGW		
	R.H.	L.H.		B	D	C	L	C2	F		Gage Insert	Insert Screw	Torx key
DVI06X-12-SDUCR/L-2-CB	59146	59147	12 x Dia.	.625	0.375	7.13	4.50	2.63	0.375	11°	21.51	TS-25-45-6M2	T-8
DVI08X-12-SDUCR/L-2-CB	59152	59153		.750	0.500	9.00	6.00	3.00	0.437	11°			
DVI10X-12-SDUCR/L-2-CB	59158	59159		.875	0.625	10.63	7.50	3.13	0.500	7°			

METRIC													
Carbide Bar Description	UPC No. 733101-		Boring Ratio	Min. Bore			Carbide Body			K°	DCGW		
	R.H.	L.H.		B	D	C	L	C2	F		Gage Insert	Insert Screw	Torx key
DVM10X-12-SDUCR/L-07-CB	59172	59173	12 x Dia.	16	10	190	120	70	9.53	11°	070204	TS-25-45-6M2	T-8
DVM12X-12-SDUCR/L-07-CB	59166	59167		19	12	216	144	72	11.10	11°			
DVM16X-12-SDUCR/L-07-CB	59178	59179		22	16	272	192	80	12.70	7°			

SDUC R/L Solution Tool!™ Integral Carbide Boring Bar Style U - Negative 3° End Cutting Edge Angle for 7° positive 55° diamond DC__ inserts

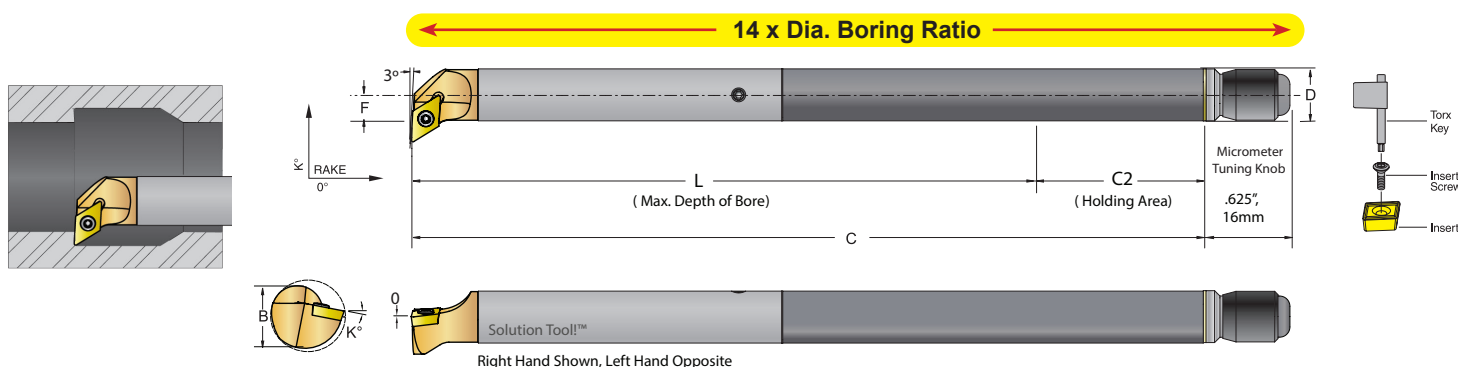

INCH													
Carbide Bar Description	UPC No. 733101-		Boring Ratio	Min. Bore			Carbide Body			K°	DCGW		
	R.H.	L.H.		B	D	C	L	C2	F		Gage Insert	Insert Screw	Torx key
DVI06X-14-SDUCR/L-2-CB	59148	59149	14 x Dia.	.625	0.375	7.88	5.25	2.63	0.375	11°	21.51	TS-25-45-6M2	T-8
DVI08X-14-SDUCR/L-2-CB	59154	59155		.750	0.500	10.00	7.00	3.00	0.437	11°			
DVI10X-14-SDUCR/L-2-CB	59160	59161		.875	0.625	11.88	8.75	3.13	0.500	7°			

METRIC													
Carbide Bar Description	UPC No. 733101-		Boring Ratio	Min. Bore			Carbide Body			K°	DCGW		
	R.H.	L.H.		B	D	C	L	C2	F		Gage Insert	Insert Screw	Torx key
DVM10X-14-SDUCR/L-07-CB	59174	59175	14 x Dia.	16	10	210	140	70	9.53	11°	070204	TS-25-45-6M2	T-8
DVM12X-14-SDUCR/L-07-CB	59168	59169		19	12	240	168	72	11.10	11°			
DVM16X-14-SDUCR/L-07-CB	59180	59181		22	16	304	224	80	12.70	7°			

Solution Tool!™ The NO! Vibration Tunable Boring Bar

SDNC R/L Solution Tool!™ Integral Carbide Boring Bar Style N - Negative 27.5° End & Side Cutting Edge Angle for 7° positive 55° diamond DC__inserts

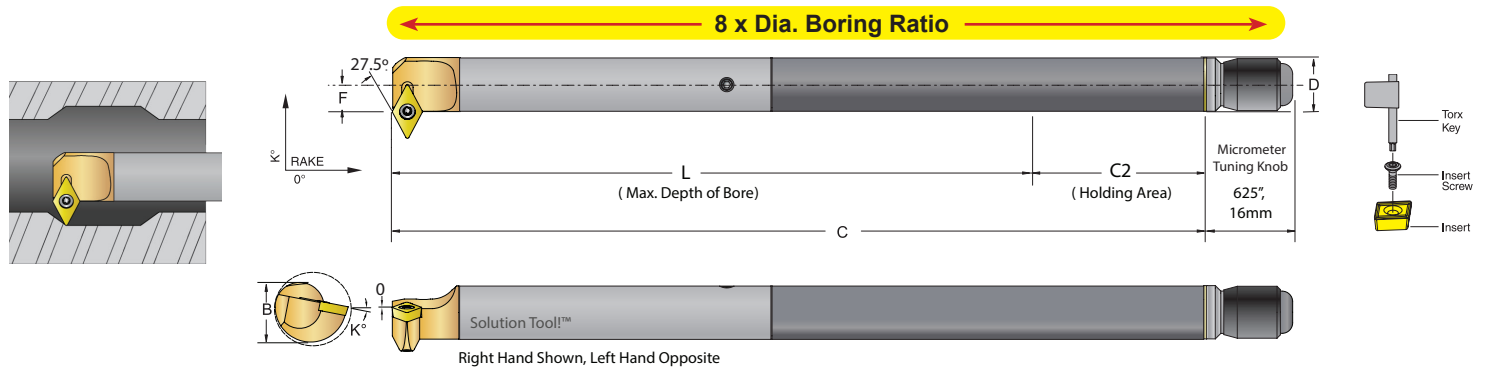

Carbide Bar Description	UPC No. 733101-		Boring Ratio	Min. Bore B	Carbide Body					K°	DCGW		
	R.H.	L.H.			D	C	L	C2	F		Gage Insert	Insert Screw	Torx key
DVI06X-08-SDNCR/L-2-CB	59094	59095	8 x Dia.	0.581	.375	5.63	3.00	2.63	0.375	11°	21.51	TS-25-45-6M2	T-8
DVI08X-08-SDNCR/L-2-CB	59102	59103		0.813	.500	7.00	4.00	3.00	0.500	11°			
DVI10X-08-SDNCR/L-2-CB	59110	59111		0.938	.625	8.13	5.00	3.13	0.562	7°			

Carbide Bar Description	UPC No. 733101-		Boring Ratio	Min. Bore B	Carbide Body					K°	DCGW		
	R.H.	L.H.			D	C	L	C2	F		Gage Insert	Insert Screw	Torx key
DVM10X-08-SDNCR/L-07-CB	59118	59119	8 x Dia.	16	10	150	80	70	9.5	11°	070204	TS-25-45-6M2	T-8
DVM12X-08-SDNCR/L-07-CB	59126	59127		20	10	150	80	70	12.7	11°			
DVM16X-08-SDNCR/L-07-CB	59134	59135		24	16	208	128	80	14.3	7°			

SDNC R/L Solution Tool!™ Integral Carbide Boring Bar Style N - Negative 27.5° End & Side Cutting Edge Angle for 7° positive 55° diamond DC__inserts

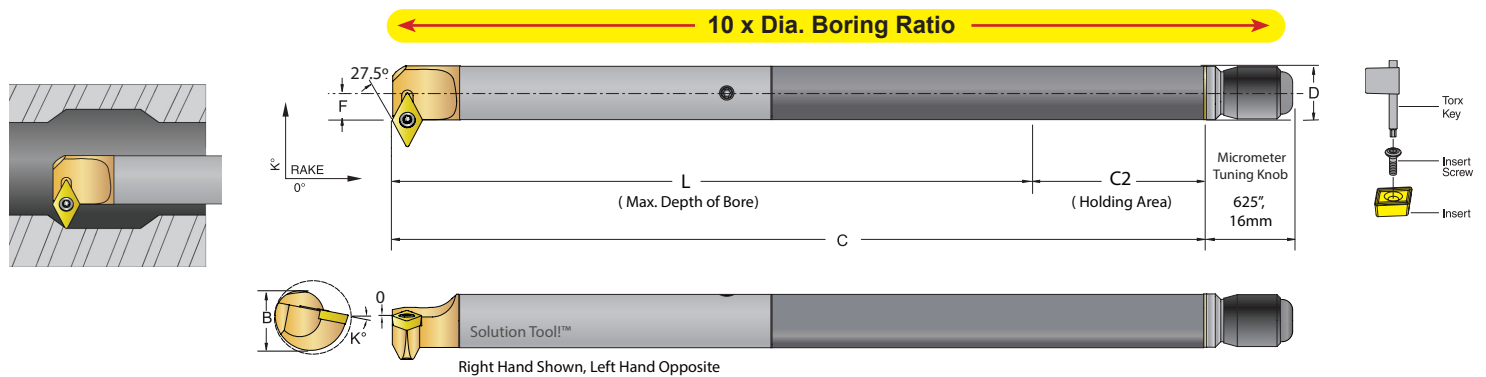

Carbide Bar Description	UPC No. 733101-		Boring Ratio	Min. Bore B	Carbide Body					K°	DCGW		
	R.H.	L.H.			D	C	L	C2	F		Gage Insert	Insert Screw	Torx key
DVI06X-10-SDNCR/L-2-CB	59096	59097	10 x Dia.	0.581	0.375	6.38	3.75	2.63	0.375	11°	21.51	TS-25-45-6M2	T-8
DVI08X-10-SDNCR/L-2-CB	59104	59105		0.813	0.500	8.00	5.00	3.00	0.500	11°			
DVI10X-10-SDNCR/L-2-CB	59112	59113		0.938	0.625	9.38	6.25	3.13	0.562	7°			

Carbide Bar Description	UPC No. 733101-		Boring Ratio	Min. Bore B	Carbide Body					K°	DCGW		
	R.H.	L.H.			D	C	L	C2	F		Gage Insert	Insert Screw	Torx key
DVM10X-10-SDNCR/L-07-CB	59120	59121	10 x Dia.	16	10	170	100	70	9.5	11°	070204	TS-25-45-6M2	T-8
DVM12X-10-SDNCR/L-07-CB	59128	59129		20	12	192	120	72	12.7	11°			
DVM16X-10-SDNCR/L-07-CB	59136	59137		24	16	240	160	80	14.3	7°			

Solution Tool!™ The NO! Vibration Tunable Boring Bar

SDNC R/L Solution Tool!™ Integral Carbide Boring Bar Style N - Negative 27.5° End & Side Cutting Edge Angle for 7° positive 55° diamond DC__ inserts

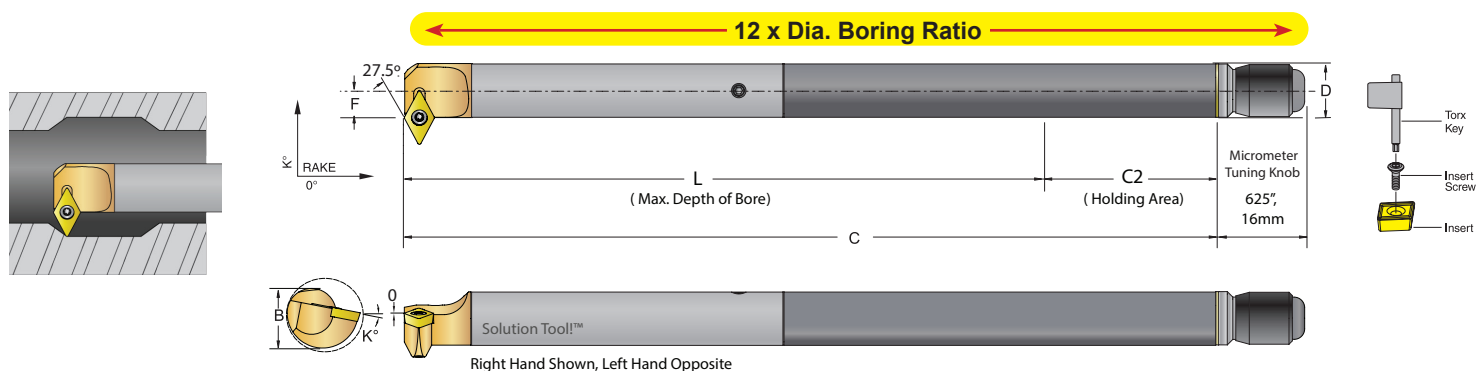

INCH													
Carbide Bar Description	UPC No. 733101-		Boring Ratio	Min. Bore		Carbide Body				DCGW			
	R.H.	L.H.		B	D	C	L	C2	F	K°	Gage Insert	Insert Screw	Torx key
DVI06X-12-SDNCR/L-2-CB	59098	59099	12 x Dia.	0.581	0.375	7.13	4.50	2.63	0.375	11°	21.51	TS-25-45-6M2	T-8
DVI08X-12-SDNCR/L-2-CB	59106	59107		0.813	0.500	9.00	6.00	3.00	0.500	11°			
DVI10X-12-SDNCR/L-2-CB	59114	59115		0.938	0.625	10.63	7.50	3.13	0.562	7°			

METRIC													
Carbide Bar Description	UPC No. 733101-		Boring Ratio	Min. Bore		Carbide Body				DCGW			
	R.H.	L.H.		B	D	C	L	C2	F	K°	Gage Insert	Insert Screw	Torx key
DVM10X-12-SDNCR/L-07-CB	59122	59123	12 x Dia.	16	10	190	120	70	9.5	11°	070204	TS-25-45-6M2	T-8
DVM12X-12-SDNCR/L-07-CB	59130	59131		20	10	190	120	70	12.7	11°			
DVM16X-12-SDNCR/L-07-CB	59138	59139		24	16	272	192	80	14.3	7°			

SDNC R/L Solution Tool!™ Integral Carbide Boring Bar Style N - Negative 27.5° End & Side Cutting Edge Angle for 7° positive 55° diamond DC__ inserts

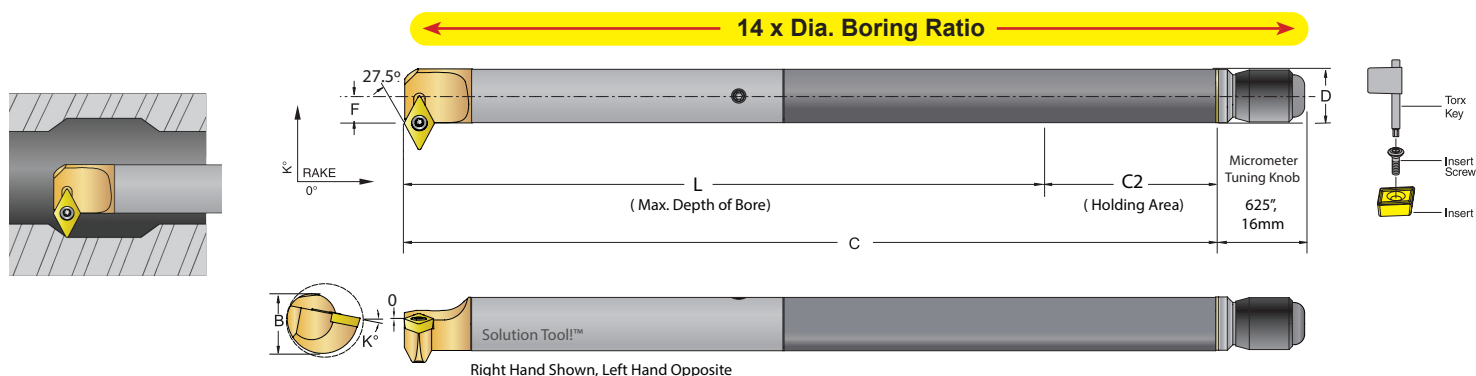

INCH													
Carbide Bar Description	UPC No. 733101-		Boring Ratio	Min. Bore		Carbide Body				DCGW			
	R.H.	L.H.		B	D	C	L	C2	F	K°	Gage Insert	Insert Screw	Torx key
DVI06X-14-SDNCR/L-2-CB	59100	59101	14 x Dia.	0.581	0.375	7.88	5.25	2.63	0.375	11°	21.51	TS-25-45-6M2	T-8
DVI08X-14-SDNCR/L-2-CB	59108	59109		0.813	0.500	10.00	7.00	3.00	0.500	11°			
DVI10X-14-SDNCR/L-2-CB	59116	59117		0.938	0.625	11.88	8.75	3.13	0.562	7°			

METRIC													
Carbide Bar Description	UPC No. 733101-		Boring Ratio	Min. Bore		Carbide Body				DCGW			
	R.H.	L.H.		B	D	C	L	C2	F	K°	Gage Insert	Insert Screw	Torx key
DVM10X-14-SDNCR/L-07-CB	59124	59125	14 x Dia.	16	10	210	140	70	9.5	11°	070204	TS-25-45-6M2	T-8
DVM12X-14-SDNCR/L-07-CB	59132	59133		20	12	240	168	72	12.7	11°			
DVM16X-14-SDNCR/L-07-CB	59140	59141		24	16	304	224	80	14.3	7°			

Solution Tool!™ The NO! Vibration Tunable Boring Bar

SDXC R/L Solution Tool!™ Integral Carbide Boring Bar Style X - Negative 5° Back Boring Cutting Edge Angle for 7° positive 55° diamond DC__ inserts

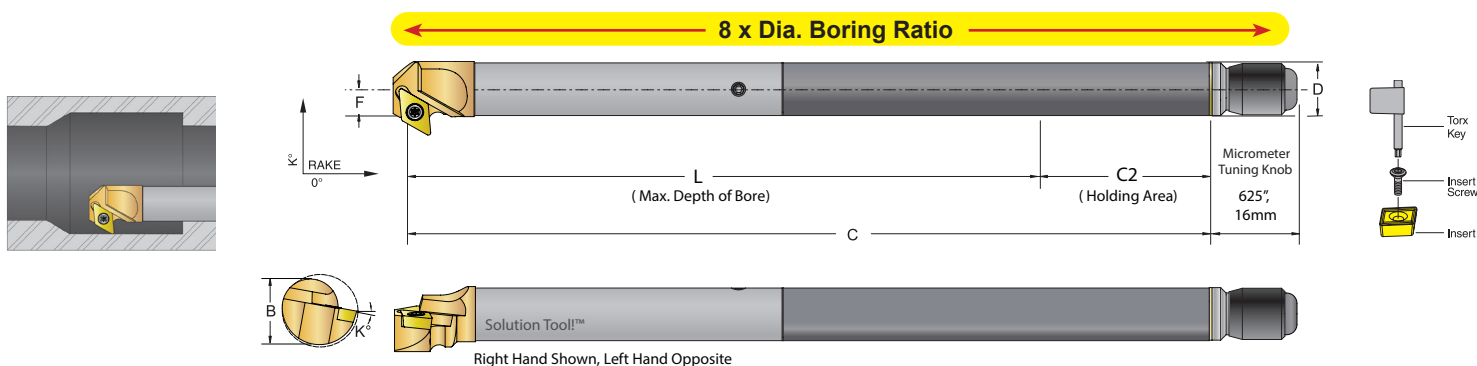

INCH													
Carbide Bar Description	UPC No. 733101-		Boring Ratio	Min. Bore		Carbide Body					DCMT		
	R.H.	L.H.		B	D	C	L	C2	F	K°	Gage Insert	Insert Screw	Torx key
DVI06X-08-SDXCR/L-2-CB	59182	59183	8 x Dia.	0.625	0.375	5.63	3.00	2.63	0.375	8°	21.51	TS-25-45-6M2	T-8
DVI08X-08-SDXCR/L-2-CB	59190	59191		0.750	0.500	7.00	4.00	3.00	0.437	6°			
DVI10X-08-SDXCR/L-2-CB	59198	59199		0.875	0.625	8.13	5.00	3.13	0.500	5°			

METRIC													
Carbide Bar Description	UPC No. 733101-		Boring Ratio	Min. Bore		Carbide Body					DCMT		
	R.H.	L.H.		B	D	C	L	C2	F	K°	Gage Insert	Insert Screw	Torx key
DVM10X-08-SDXCR/L-07-CB	59206	59207	8 x Dia.	17	10	150	80	70	9.53	8°	070204	TS-25-45-6M2	T-8
DVM12X-08-SDXCR/L-07-CB	59214	59215		21	12	168	96	72	11.10	6°			
DVM16X-08-SDXCR/L-07-CB	59222	59223		22	16	208	128	80	12.70	5°			

SDXC R/L Solution Tool!™ Integral Carbide Boring Bar Style X - Negative 5° Back Boring Cutting Edge Angle for 7° positive 55° diamond DC__ inserts

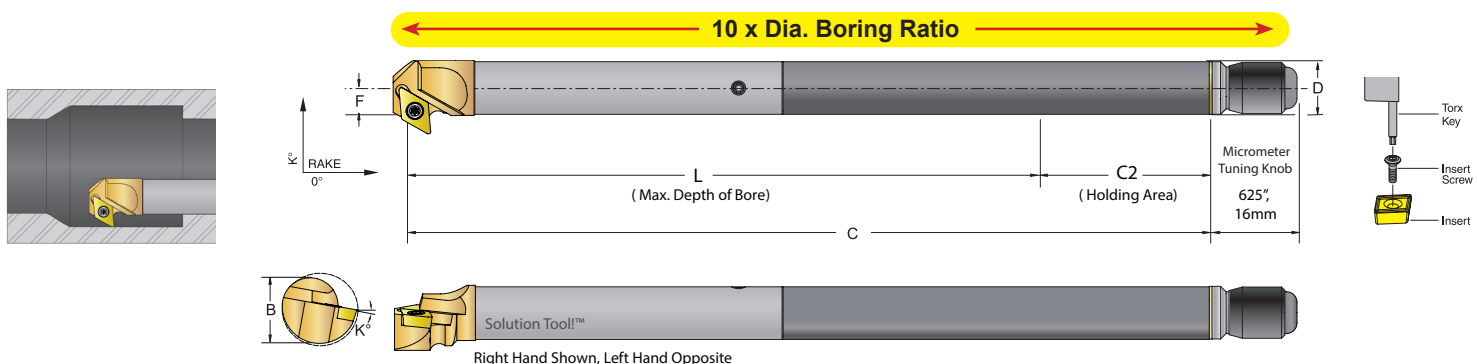

INCH													
Bar Description	UPC No. 733101-		Boring Ratio	Min. Bore		Carbide Body					DCMT		
	R.H.	L.H.		B	D	C	L	C2	F	K°	Gage Insert	Insert Screw	Torx key
DVI06X-10-SDXCR/L-2-CB	59184	59185	10 x Dia.	0.625	0.375	6.38	3.75	2.63	0.375	8°	21.51	TS-25-45-6M2	T-8
DVI08X-10-SDXCR/L-2-CB	59192	59193		0.750	0.500	8.00	5.00	3.00	0.437	6°			
DVI10X-10-SDXCR/L-2-CB	59200	59201		0.875	0.625	9.38	6.25	3.13	0.500	5°			

METRIC													
Bar Description	UPC No. 733101-		Boring Ratio	Min. Bore		Carbide Body					DCMT		
	R.H.	L.H.		B	D	C	L	C2	F	K°	Gage Insert	Insert Screw	Torx key
DVM10X-10-SDXCR/L-07-CB	59208	59209	10 x Dia.	17	10	170	100	70	9.53	8°	070204	TS-25-45-6M2	T-8
DVM12X-10-SDXCR/L-07-CB	59216	59217		21	12	192	120	72	11.10	6°			
DVM16X-10-SDXCR/L-07-CB	59224	59225		22	16	240	160	80	12.70	5°			

Solution Tool!™ The NO! Vibration Tunable Boring Bar

SDXC R/L Solution Tool!™ Integral Carbide Boring Bar Style X - Negative 5° Back Boring Cutting Edge Angle for 7° positive 55° diamond DC__ inserts

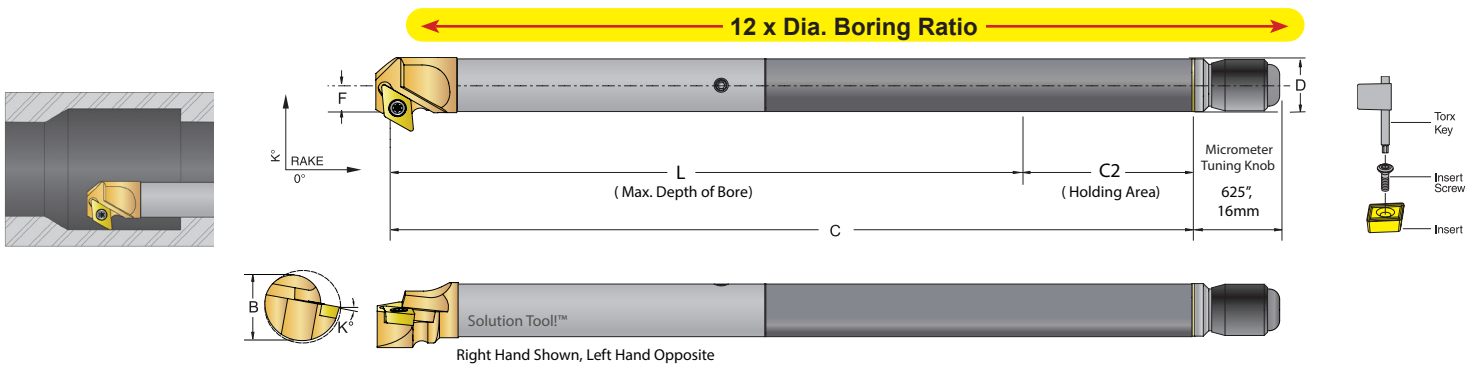

INCH													
Carbide Bar Description	UPC No. 733101-		Boring Ratio	Min. Bore			Carbide Body			DCMT			
	R.H.	L.H.		B	D	C	L	C2	F	K°	Gage Insert	Insert Screw	Torx key
DVI06X-12-SDXCR/L-2-CB	59186	59187	12 x Dia.	0.625	0.375	7.13	4.50	2.63	0.375	8°	21.51	TS-25-45-6M2	T-8
DVI08X-12-SDXCR/L-2-CB	59194	59195		0.750	0.500	9.00	6.00	3.00	0.437	6°			
DVI10X-12-SDXCR/L-2-CB	59202	59203		0.875	0.625	10.63	7.50	3.13	0.500	5°			

METRIC													
Carbide Bar Description	UPC No. 733101-		Boring Ratio	Min. Bore			Carbide Body			DCMT			
	R.H.	L.H.		B	D	C	L	C2	F	K°	Gage Insert	Insert Screw	Torx key
DVM10X-12-SDXCR/L-07-CB	59210	59211	12 x Dia.	17	10	190	120	70	9.53	8°	070204	TS-25-45-6M2	T-8
DVM12X-12-SDXCR/L-07-CB	59218	59219		21	12	216	144	72	11.10	6°			
DVM16X-12-SDXCR/L-07-CB	59226	59227		22	16	272	192	80	12.70	5°			

SDXC R/L Solution Tool!™ Integral Carbide Boring Bar Style X - Negative 5° Back Boring Cutting Edge Angle for 7° positive 55° diamond DC__ inserts

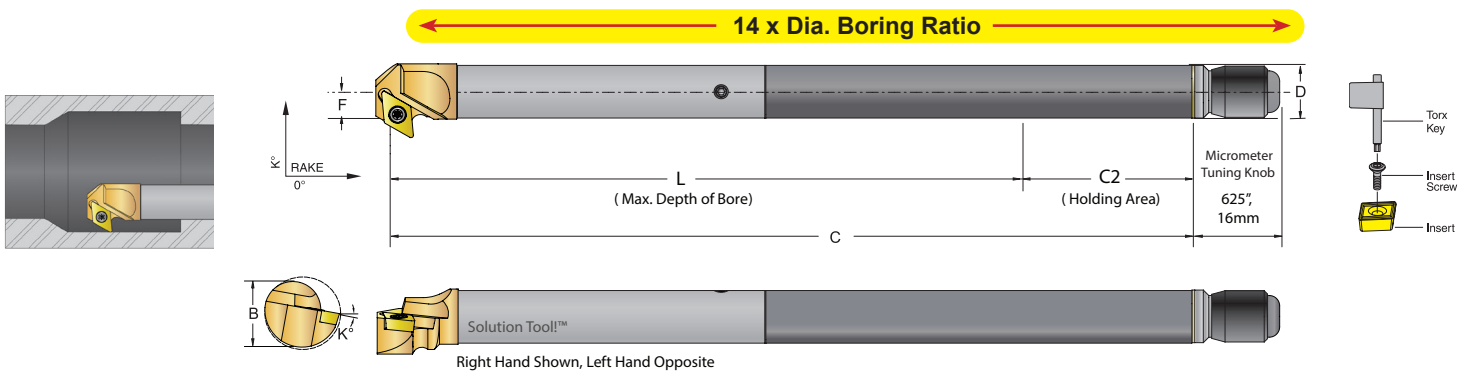

INCH													
Carbide Bar Description	UPC No. 733101-		Boring Ratio	Min. Bore			Carbide Body			DCMT			
	R.H.	L.H.		B	D	C	L	C2	F	K°	Gage Insert	Insert Screw	Torx key
DVI06X-14-SDXCR/L-2-CB	59188	59189	14 x Dia.	0.625	0.375	7.88	5.25	2.63	0.375	7°	21.51	TS-25-45-6M2	T-8
DVI08X-14-SDXCR/L-2-CB	59196	59197		0.750	0.500	10.00	7.00	3.00	0.437	15°			
DVI10X-14-SDXCR/L-2-CB	59204	59205		0.875	0.625	11.88	8.75	3.13	0.500	10°			

METRIC													
Carbide Bar Description	UPC No. 733101-		Boring Ratio	Min. Bore			Carbide Body			DCMT			
	R.H.	L.H.		B	D	C	L	C2	F	K°	Gage Insert	Insert Screw	Torx key
DVM10X-14-SDXCR/L-07-CB	59212	59213	14 x Dia.	17	10	210	140	70	9.53	8°	070204	TS-25-45-6M2	T-8
DVM12X-14-SDXCR/L-07-CB	59220	59221		21	12	240	168	72	11.10	6°			
DVM16X-14-SDXCR/L-07-CB	59228	59229		22	16	304	224	80	12.70	5°			

Solution Tool!™ The NO! Vibration Tunable Boring Bar

STUC R/L Solution Tool!™ Integral Carbide Boring Bar Style U - Negative 3° End Cutting Edge Angle for 7° positive triangle TC__ inserts

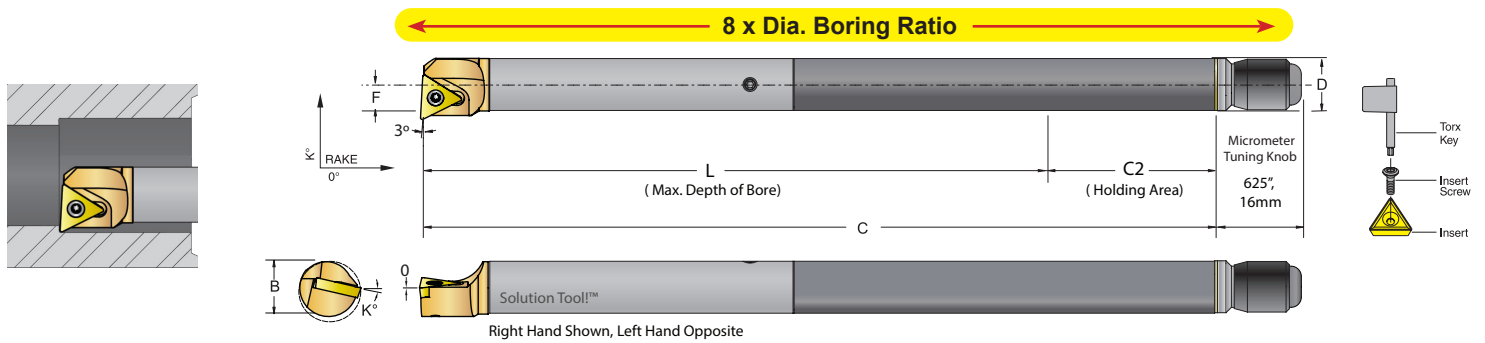

INCH													
Carbide Bar Description	UPC No. 733101-		Boring Ratio	Min. Bore		Carbide Body					TCMT		
	R.H.	L.H.		B	D	C	L	C2	F	K°	Gage Insert	Insert Screw	Torx key
DVI08X-08-STUCR/L-2-CB	59410	59411	8 x Dia.	0.625	0.500	7.00	4.00	3.00	.312	13°	21.51	TS-25-45-6M2	T-8
DVI10X-08-STUCR/L-2-CB	59412	59413		0.781	0.625	8.13	5.00	3.13	.406	10°			

METRIC													
Carbide Bar Description	UPC No. 733101-		Boring Ratio	Min. Bore		Carbide Body					TCMT		
	R.H.	L.H.		B	D	C	L	C2	F	K°	Gage Insert	Insert Screw	Torx key
DVM12X-08-STUCR/L-11-CB	59424	59425	8 x Dia.	16	12	168	96	72	7.92	13°	110204	TS-25-45-6M2	T-8
DVM16X-08-STUCR/L-16-CB	59426	59427		20	16	208	128	80	10.31	10°			

STUC R/L Solution Tool!™ Integral Carbide Boring Bar Style U - Negative 3° End Cutting Edge Angle for 7° positive triangle TC__ inserts

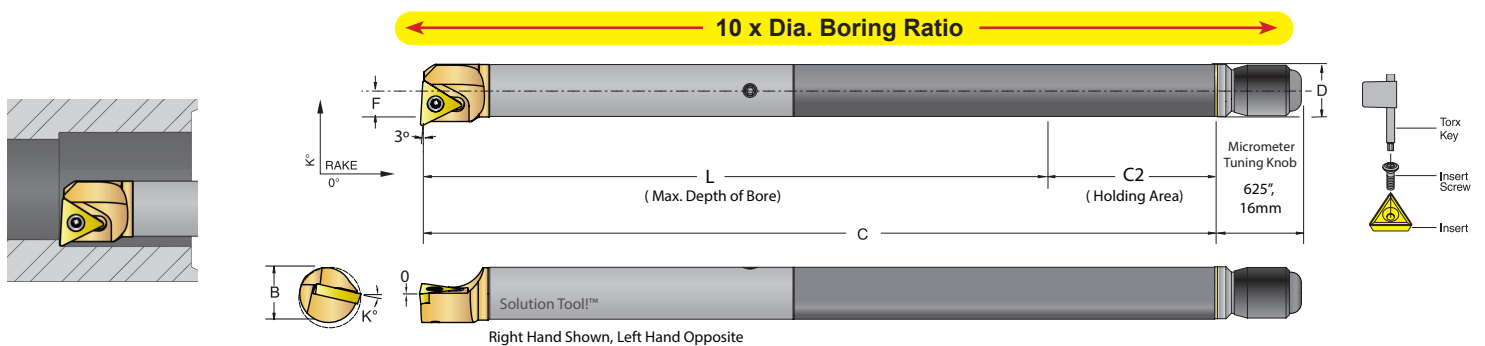

INCH													
Carbide Bar Description	UPC No. 733101-		Boring Ratio	Min. Bore		Carbide Body					TCMT		
	R.H.	L.H.		B	D	C	L	C2	F	K°	Gage Insert	Insert Screw	Torx key
DVI08X-10-STUCR/L-2-CB	59262	59263	10 x Dia.	0.625	0.500	8.00	5.00	3.00	.312	13°	21.51	TS-25-45-6M2	T-8
DVI10X-10-STUCR/L-2-CB	59268	59269		0.781	0.625	9.38	6.25	3.13	.406	10°			

METRIC													
Carbide Bar Description	UPC No. 733101-		Boring Ratio	Min. Bore		Carbide Body					TCMT		
	R.H.	L.H.		B	D	C	L	C2	F	K°	Gage Insert	Insert Screw	Torx key
DVM12X-10-STUCR/L-11-CB	59306	59307	10 x Dia.	16	12	192	120	72	7.92	13°	110204	TS-25-45-6M2	T-8
DVM16X-10-STUCR/L-16-CB	59312	59313		20	16	240	160	80	10.31	10°			

Solution Tool!™ The NO! Vibration Tunable Boring Bar

STUC R/L Solution Tool!™ Integral Carbide Boring Bar Style U - Negative 3° End Cutting Edge Angle for 7° positive triangle TC__ inserts

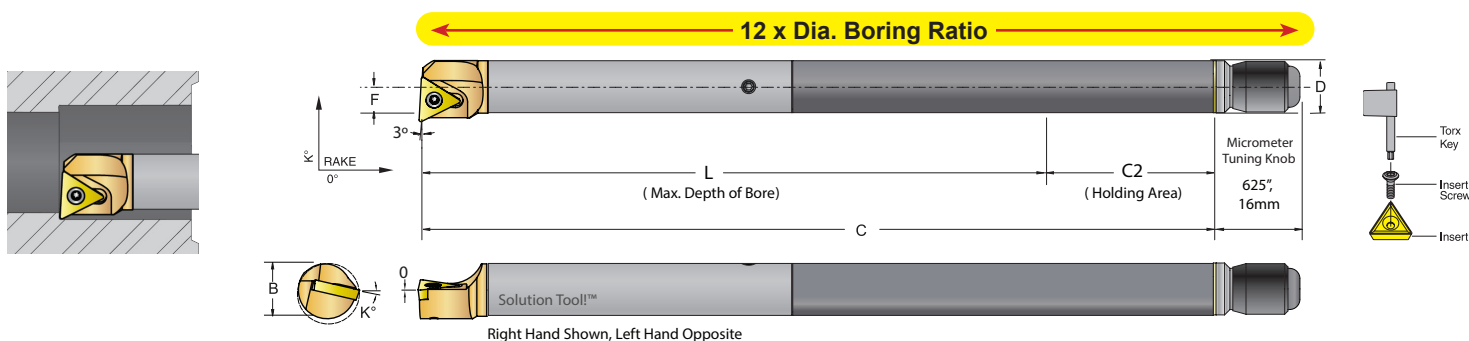

INCH													
Carbide Bar Description	UPC No. 733101-		Boring Ratio	Min. Bore		Carbide Body				TCMT			
	R.H.	L.H.		B	D	C	L	C2	F	K°	Gage Insert	Insert Screw	Torx key
DVI08X-12-STUCR/L-2-CB	59264	59265	12 x Dia.	0.625	0.500	9.00	6.00	3.00	.312	13°	21.51	TS-25-45-6M2	T-8
DVI10X-12-STUCR/L-2-CB	59270	59271		0.781	0.625	10.63	7.50	3.13	.406	10°			

METRIC													
Carbide Bar Description	UPC No. 733101-		Boring Ratio	Min. Bore		Carbide Body				TCMT			
	R.H.	L.H.		B	D	C	L	C2	F	K°	Gage Insert	Insert Screw	Torx key
DVM12X-12-STUCR/L-11-CB	59308	59309	12 x Dia.	16	12	216	144	72	7.92	13°	110204	TS-25-45-6M2	T-8
DVM16X-12-STUCR/L-16-CB	59314	59315		20	16	272	192	80	10.31	10°			

STUC R/L Solution Tool!™ Integral Carbide Boring Bar Style U - Negative 3° End Cutting Edge Angle for 7° positive triangle TC__ inserts

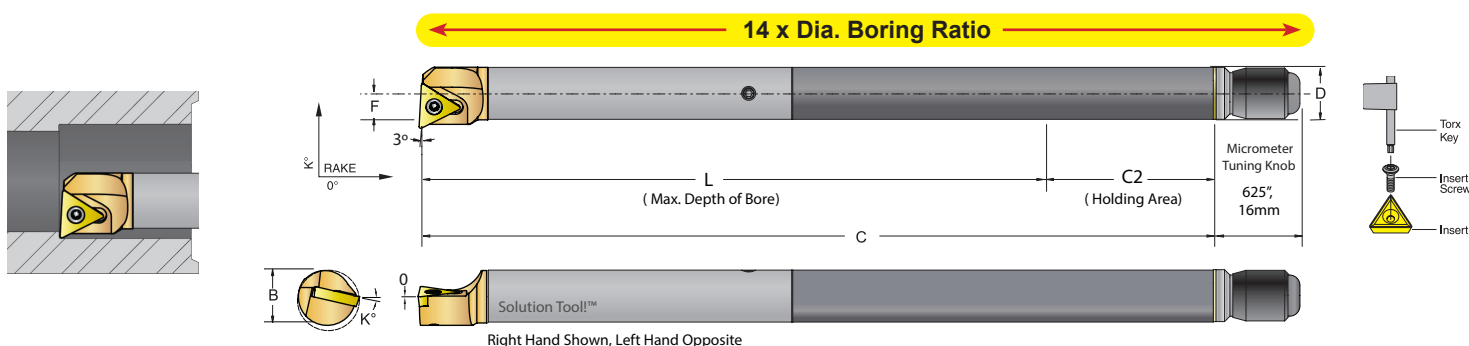

INCH													
Carbide Bar Description	UPC No. 733101-		Boring Ratio	Min. Bore		Carbide Body				TCMT			
	R.H.	L.H.		B	D	C	L	C2	F	K°	Gage Insert	Insert Screw	Torx key
DVI08X-14-STUCR/L-2-CB	59266	59267	14 x Dia.	0.625	0.500	10.00	7.00	3.00	.312	13°	21.51	TS-25-45-6M2	T-8
DVI10X-14-STUCR/L-2-CB	59272	59273		0.781	0.625	11.78	8.75	3.13	.406	10°			

METRIC													
Carbide Bar Description	UPC No. 733101-		Boring Ratio	Min. Bore		Carbide Body				TCMT			
	R.H.	L.H.		B	D	C	L	C2	F	K°	Gage Insert	Insert Screw	Torx key
DVM12X-14-STUCR/L-11-CB	59310	59311	14 x Dia.	16	12	240	168	72	7.92	13°	110204	TS-25-45-6M2	T-8
DVM16X-14-STUCR/L-16-CB	59316	59317		20	16	304	224	80	10.31	10°			

Solution Tool!™ The NO! Vibration Tunable Boring Bar

STUP R/L Solution Tool!™ Integral Carbide Boring Bar Style U - Negative 3° End Cutting Edge Angle for 7° positive triangle TP__ inserts

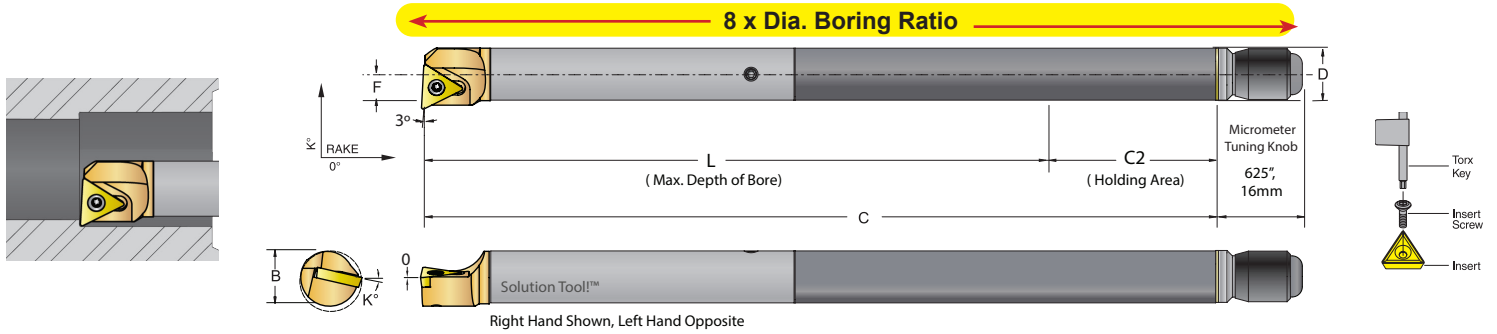

INCH

Carbide Bar Description	UPC No. 733101-		Boring Ratio	Min. Bore		Carbide Body					TPGW		
	R.H.	L.H.		B	D	C	L	C2	F	K°	Gage Insert	Insert Screw	Torx key
DV104X-08-STUPR/L-1.2-CB	59230	59231	8 x Dia.	0.312	0.250	4.00	2.00	2.00	.143	11°	1.21.20.2	TS-06	T-6
DV105X-08-STUPR/L-1.2-CB	59238	59239		0.383	0.312	5.00	2.50	2.50	.177	8°	1.21.20.2	TS-06	T-6
DV106X-08-STUPR/L-1.2-CB	59246	59247		0.447	0.375	5.63	3.00	2.63	.220	4°	1.21.20.2	TS-06	T-6
DV108X-08-STUPR/L-2-CB	60265	60266		0.625	0.500	7.00	4.00	3.00	.312	2°	21.51	TS-25-45-6M2	T-8
DV110X-08-STUPR/L-2-CB	60273	60274		0.781	0.625	8.13	5.00	3.13	.406	0°	21.51	TS-25-45-6M2	T-8

METRIC

Carbide Bar Description	UPC No. 733101-		Boring Ratio	Min. Bore		Carbide Body					TPGW		
	R.H.	L.H.		B	D	C	L	C2	F	K°	Gage Insert	Insert Screw	Torx key
DVM06X-08-STUPR/L-06-CB	59274	59275	8 x Dia.	8	6	96	48	48	3.63	11°	06T101	TS-06	T-6
DVM08X-08-STUPR/L-06-CB	59282	59283		10	8	128	64	64	4.50	8°	06T101	TS-06	T-6
DVM10X-08-STUPR/L-06-CB	59290	59291		12	10	150	80	70	5.59	4°	06T101	TS-06	T-6
DVM12X-08-STUPR/L-11-CB	60281	60282		16	12	168	96	72	7.92	2°	110204	TS-25-45-6M2	T-8
DVM16X-08-STUPR/L-11-CB	60289	60290		20	16	208	128	80	10.31	0°	110204	TS-25-45-6M2	T-8

STUP R/L Solution Tool!™ Integral Carbide Boring Bar Style U - Negative 3° End Cutting Edge Angle for 7° positive triangle TP__ inserts

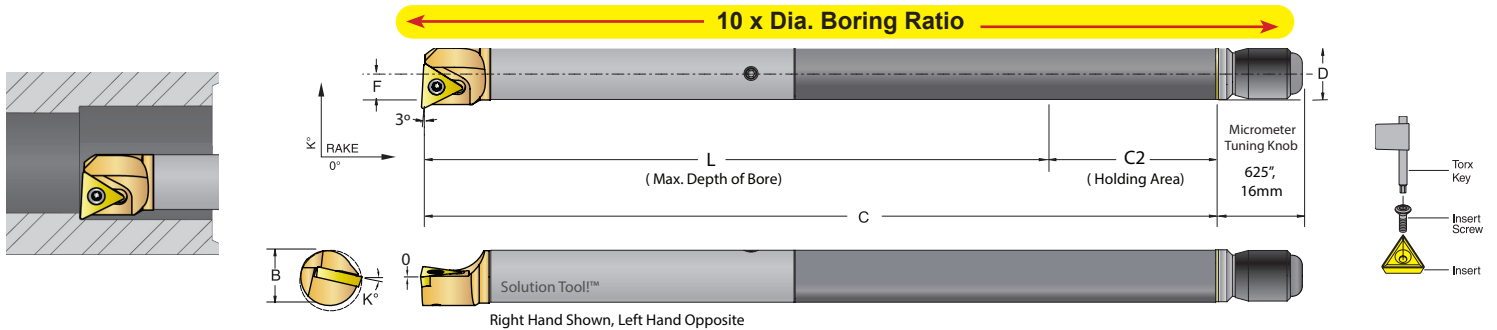

INCH

Carbide Bar Description	UPC No. 733101-		Boring Ratio	Min. Bore		Carbide Body					TPGW		
	R.H.	L.H.		B	D	C	L	C2	F	K°	Gage Insert	Insert Screw	Torx key
DV104X-10-STUPR/L-1.2-CB	59232	59233	10 x Dia.	0.312	0.250	4.50	2.50	2.00	.143	11°	1.21.20.2	TS-06	T-6
DV105X-10-STUPR/L-1.2-CB	59240	59241		0.383	0.312	5.62	3.12	2.50	.177	8°	1.21.20.2	TS-06	T-6
DV106X-10-STUPR/L-1.2-CB	59248	59249		0.447	0.375	6.38	3.75	2.63	.220	4°	1.21.20.2	TS-06	T-6
DV108X-10-STUPR/L-2-CB	60267	60268		0.625	0.500	8.00	5.00	3.00	.312	2°	21.51	TS-25-45-6M2	T-8
DV110X-10-STUPR/L-2-CB	60275	60276		0.781	0.625	9.38	6.25	3.13	.406	0°	21.51	TS-25-45-6M2	T-8

METRIC

Carbide Bar Description	UPC No. 733101-		Boring Ratio	Min. Bore		Carbide Body					TPGW		
	R.H.	L.H.		B	D	C	L	C2	F	K°	Gage Insert	Insert Screw	Torx key
DVM06X-10-STUPR/L-06-CB	59276	59277	10 x Dia.	8	6	108	60	48	3.63	11°	06T101	TS-06	T-6
DVM08X-10-STUPR/L-06-CB	59284	59285		10	8	144	80	64	4.50	8°	06T101	TS-06	T-6
DVM10X-10-STUPR/L-06-CB	59292	59293		12	10	170	100	70	5.59	4°	06T101	TS-06	T-6
DVM12X-10-STUPR/L-11-CB	60283	60284		16	12	192	120	72	7.92	2°	110204	TS-25-45-6M2	T-8
DVM16X-10-STUPR/L-11-CB	60291	60292		20	16	240	160	80	10.31	0°	110204	TS-25-45-6M2	T-8

Solution Tool!™ The NO! Vibration Tunable Boring Bar

STUP R/L Solution Tool!™ Integral Carbide Boring Bar Style U - Negative 3° End Cutting Edge Angle for 7° positive triangle TP__ inserts

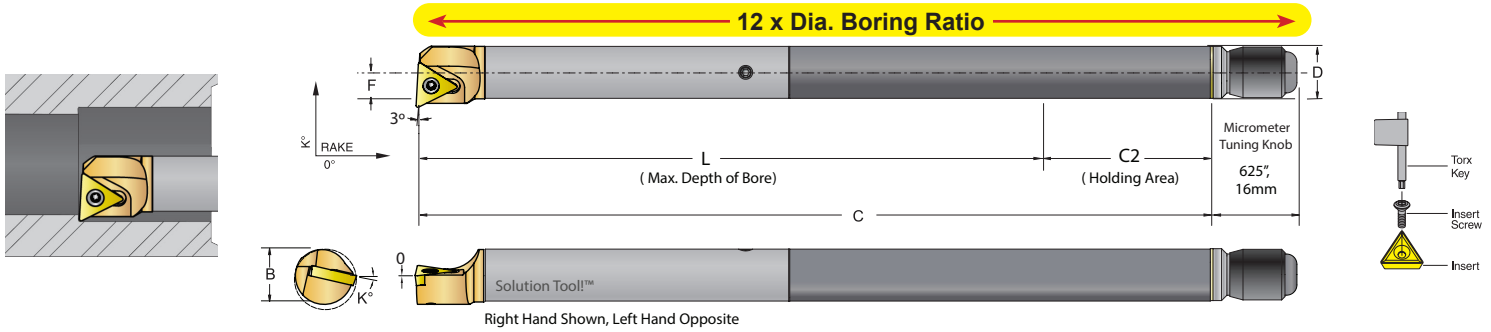

Inch		UPC No. 733101-		Boring Ratio	Carbide Body						TPGW		
Carbide Bar Description	R.H.	L.H.	Min. Bore B		D	C	L	C2	F	K°	Gage Insert	Insert Screw	Torx key
DVI04X-12-STUPR/L-1.2-CB	59234	59235	12 x Dia.	0.312	0.250	5.00	3.00	2.00	.143	11°	1.21.20.2	TS-06	T-6
DVI05X-12-STUPR/L-1.2-CB	59242	59243		0.383	0.312	6.24	3.74	2.50	.177	8°	1.21.20.2	TS-06	T-6
DVI06X-12-STUPR/L-1.2-CB	59250	59251		0.447	0.375	7.13	4.50	2.63	.220	4°	1.21.20.2	TS-06	T-6
DVI08X-12-STUPR/L-2-CB	60269	60270		0.625	0.500	9.00	6.00	3.00	.312	2°	21.51	TS-25-45-6M2	T-8
DVI10X-12-STUPR/L-2-CB	60277	60278		0.781	0.625	10.63	7.50	3.13	.406	0°	21.51	TS-25-45-6M2	T-8

Metric		UPC No. 733101-		Boring Ratio	Carbide Body						TPGW		
Carbide Bar Description	R.H.	L.H.	Min. Bore B		D	C	L	C2	F	K°	Gage Insert	Insert Screw	Torx key
DVM06X-12-STUPR/L-06-CB	59278	59279	12 x Dia.	8	6	120	72	48	3.63	11°	06T101	TS-06	T-6
DVM08X-12-STUPR/L-06-CB	59286	59287		10	8	160	96	64	4.50	8°	06T101	TS-06	T-6
DVM10X-12-STUPR/L-06-CB	59294	59295		12	10	190	120	70	5.59	4°	06T101	TS-06	T-6
DVM12X-12-STUPR/L-11-CB	60285	60286		16	12	216	144	72	7.92	2°	110204	TS-25-45-6M2	T-8
DVM16X-12-STUPR/L-11-CB	60293	60294		20	16	272	192	80	10.31	0°	110204	TS-25-45-6M2	T-8

STUP R/L Solution Tool!™ Integral Carbide Boring Bar Style U - Negative 3° End Cutting Edge Angle for 7° positive triangle TP__ inserts

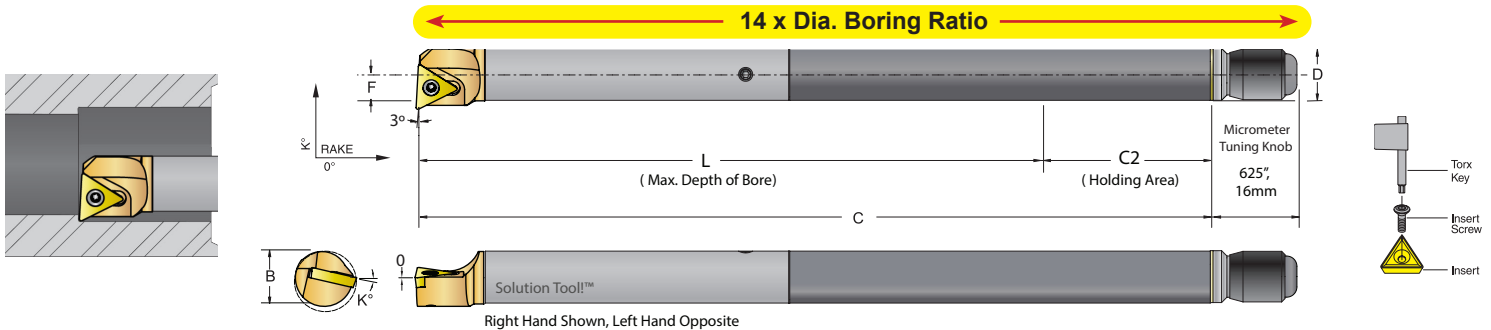

INCH		UPC No. 733101-		Boring Ratio	Carbide Body						TPGW		
Carbide Bar Description	R.H.	L.H.	Min. Bore B		D	C	L	C2	F	K°	Gage Insert	Insert Screw	Torx key
DVI04X-14-STUPR/L-1.2-CB	59236	59237	14 x Dia.	0.312	0.250	5.50	3.50	2.00	.143	11°	1.21.20.2	TS-06	T-6
DVI05X-14-STUPR/L-1.2-CB	59244	59245		0.383	0.312	6.86	4.37	2.50	.177	8°	1.21.20.2	TS-06	T-6
DVI06X-14-STUPR/L-1.2-CB	59252	59253		0.447	0.375	7.88	5.25	2.63	.220	4°	1.21.20.2	TS-06	T-6
DVI08X-14-STUPR/L-2-CB	60271	60272		0.625	0.500	10.00	7.00	3.00	.312	2°	21.51	TS-25-45-6M2	T-8
DVI10X-14-STUPR/L-2-CB	60279	60280		0.781	0.625	11.88	8.75	3.13	.406	0°	21.51	TS-25-45-6M2	T-8

METRIC		UPC No. 733101-		Boring Ratio	Carbide Body						TPGW		
Carbide Bar Description	R.H.	L.H.	Min. Bore B		D	C	L	C2	F	K°	Gage Insert	Insert Screw	Torx key
DVM06X-14-STUPR/L-06-CB	59280	59281	14 x Dia.	8	6	132	84	48	3.63	11°	06T101	TS-06	T-6
DVM08X-14-STUPR/L-06-CB	59288	59289		10	8	176	112	64	4.50	8°	06T101	TS-06	T-6
DVM10X-14-STUPR/L-06-CB	59296	59297		12	10	210	140	70	5.59	4°	06T101	TS-06	T-6
DVM12X-14-STUPR/L-11-CB	60287	60288		16	12	240	168	72	7.92	2°	110204	TS-25-45-6M2	T-8
DVM16X-14-STUPR/L-11-CB	60295	60296		20	16	304	224	80	10.31	0°	110204	TS-25-45-6M2	T-8

Solution Tool!™ The NO! Vibration Tunable Boring Bar

Solution Tool!™

The NO! Vibration Tunable Boring Bar
Makes Deep Hole Boring Simple!

SIMPLE - PRECISE - QUICK - RIGID

Quick Change Modular

The NO! Vibration Tunable Boring Bar for Medium Boring Operation
Engineered for multi boring and threading applications on medium diameter holes,
and cutting depth to 14 x Boring Bar Diameter.

Multi Boring and Threading Applications

Better Machining Performance

Higher Workmanship Quality

Longer Cutting Insert Life

The technology behind the Solution Tool!™ the "Quick Change Modular"
NO! Vibration Tunable Boring Bars, is to perform simple, precise and reliable
when deep boring medium sizes holes, with close machining tolerance and
high surface finish, in multi boring and threading applications.

The "Quick Change Modular" NO! Vibration Tunable Boring Bars, is a two part construction.
The body where the boring bar is held, and the housing that holds the dampener, and brazed
together with Silver Alloy. The braze is the buffer zone where the frequencies generate
from the cutting operation are stopped.

To maximize performance in deep boring operation,
the "Quick Change Modular Body" is Offered in two versions;

Steel Body

The steel body for boring depth up to
12 x Boring Bar Diameter

Carbide Body

The carbide body rigidity, stability, and strength,
allows to bore at higher cutting rate, heavier material
removal, longer depth of cut, close working
tolerances and higher surface finish.

Boring Bar Sizes

Inch: 3/4" Dia., 1" Dia. 1 1/8" Dia.
Metric: 20mm Dia., 25mm Dia., 32mm Dia.,

Boring Ratio: 8 x Dia., 10 x Dia., 12 x Dia., 14 x Dia.

Positive Inserts Geometry:

for Quick Change Modular Head:
CCMT CPMT DCMT
TCMT TPMT VCMT WCMT

Lay-Down Threading Insert:

16-A60 22-N60

DorNotch Threading Insert:

NG 3

On Edge Threading Insert:

TNMC43

Coolant Inlet

Micrometer Tuning Knob

Allows to fine tune the mechanical dampener
at a precise position. Neutralize the boring
bar frequencies with no vibration while boring
for a smooth surface finish and close tolerances. Can be
removed and replaced with a coolant inlet.

Body

Offered in two versions
Steel Body; up to 12 x Dia. Boring depth.
Carbide Body; for higher boring performance over
the Steel body.

Brazed Connection

Connects the boring bar body with the housing, the
combination of the correct silver alloy and the thickness of
the braze makes brazing strong and unbreakable, but flexible
under the cutting pressure and interrupt cuts, and creating a
buffer zone that increases damping to stop the frequencies
developed in the boring operation.

Dampener Position Locking Screw

The screw is released before re-tuning
and locked after tuning is complete

Housing

Made of heat treated alloy steel, brazed with the body,
the inside of the housing holds the mechanical dampener and
on the face is attached the Quick Change Modular Collar Head.

Quick Change Modular Head Collar

Made of heat treated alloy steel and TiN Coated.
Precisely and rigid attaches on to the housing face.
The face of the Collar, has a 60° serrated groove to expand
the surface contact with the Quick Change Heads, for maximum
locking rigidity and precise interchangeability.

Quick Change Modular Head

Made of heat treated alloy steel and TiN Coated. Locks onto 60° serrated face
of the collar face with three cup screws precisely and rigid, making interchangeability
easy and quick. The Thru Coolant System enhances boring performance, quality and
longer insert life. The insert is kept at constant temperature clean and undamaged
cutting edge, and removes chips from the bore while machining.

Solution Tool!™ Quick Change Modular Boring Bar Body & Heads

The NO! Vibration Tunable Boring Bar for Multi boring and Threading Applications on Medium Diameter Holes

Makes Deep Hole Boring Simple!

1 SCLC
R/L Quick Change
Boring Bar Head
With Thru Coolant

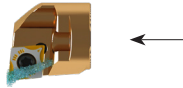

2 SDNC
R/L Quick Change
Boring Bar Head
With Thru Coolant

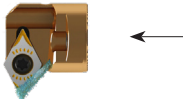

3 SDQC
R/L Quick Change
Boring Bar Head
With Thru Coolant



4 SDUC
R/L Quick Change
Boring Bar Head
With Thru Coolant



5 SDXC
R/L Quick Change
Boring Bar Head
With Thru Coolant

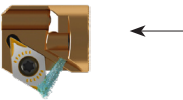

6 STUC
R/L Quick Change
Boring Bar Head
With Thru Coolant

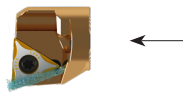

7 SVUC
R/L Quick Change
Boring Bar Head
With Thru Coolant



8 SWLC
R/L Quick Change
Boring Bar Head
With Thru Coolant



9 SN
R/L Quick Change
Threading Bar Head
With Thru Coolant



One Solution Tool!™
Modular Carbide & Steel Body

Nine
Interchangeable Heads

Solution Tool!™ The NO! Vibration Tunable Boring Bar

DV_08_MQBBN_ Solution Tool!™ Thru Coolant Quick Change Modular Boring Bar Body

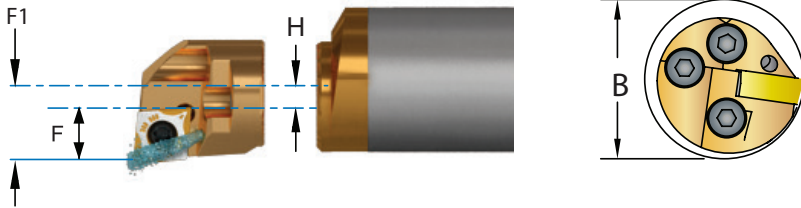
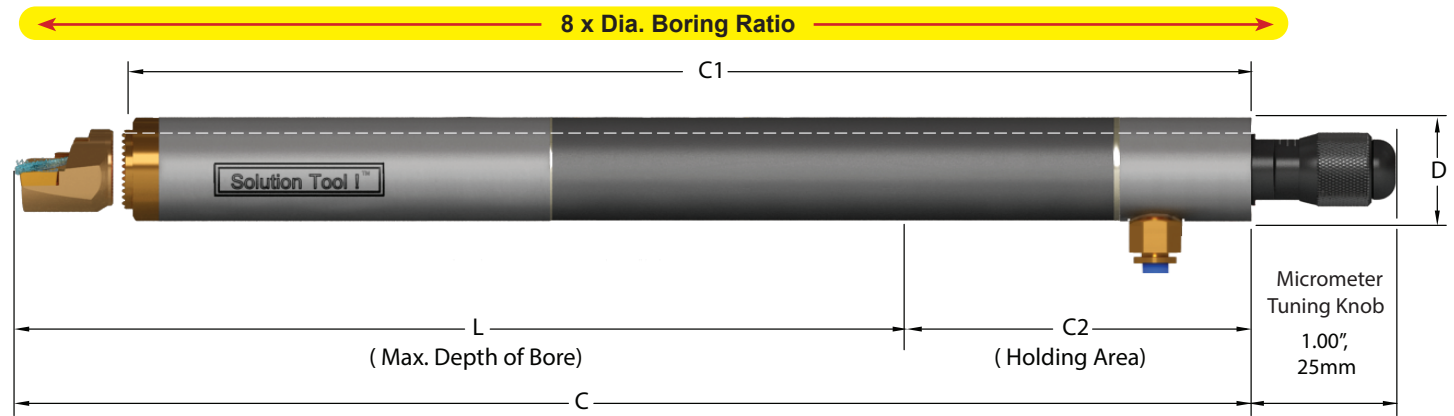

$$F1^* = F + H$$

$$\text{Min Bore} = B + (H \times 2)^*$$

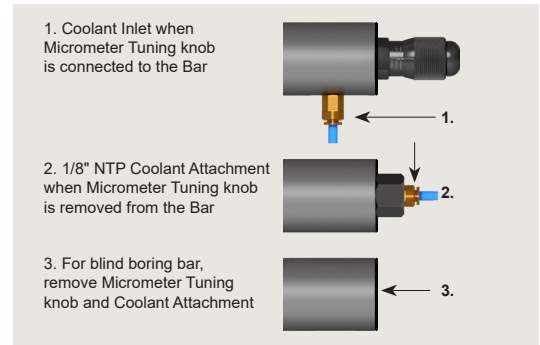

Inch		UPC No. 733101-	Steel Body								Modular Head* CBBB	Coolant Bore Dia.	Coolant Attachment Thread	
Steel Bar Description	Neutral		Boring Ratio	D	C	C1	L	C2	H	F1*	Min. Bore B**			
DV112X-08-MQBBN-10-SB	59428		8 x Dia.	0.750	9.00	8.20	6.00	3.00	0	F1=F+H	MB+B+(Hx2)	DBOMH-12/20M	0.157	1/8"-27NTP
DV116X-08-MQBBN-12-SB	59340	1.000		12.00	11.20	8.00	4.00	0.125	0.157					
DV120X-08-MQBBN-15-SB	59341	1.250		15.00	14.20	10.00	5.00	0.250	0.195					
Metric		UPC No. 733101-	Steel Body								Modular Head* CBBB	Coolant Bore Dia.	Coolant Attachment Thread	
Steel Bar Description	Neutral		Boring Ratio	D	C	C1	L	C2	H	F1*	Min. Bore B**			
DVM20X-08-MQBBN-0240-SB	59430		8 x Dia.	20	240	219.68	160	80	0	F1=F+H	MB+B+(Hx2)	DBOMH-12/20M	4	1/8"-27NTP
DVM25X-08-MQBBN-0300-SB	59345	25		300	279.68	200	100	2.5	4					
DVM32X-08-MQBBN-0384-SB	59346	32		384	363.68	256	128	6	5					
Inch		UPC No. 733101-	Carbide Body								Modular Head* CBBB	Coolant Bore Dia.	Coolant Attachment Thread	
Carbide Bar Description	Neutral		Boring Ratio	D	C	C1	L	C2	H	F1*	Min. Bore B**			
DV112X-08-MQBBN-10-CB	60360		8 x Dia.	0.750	9.00	8.20	6.00	3.00	0	F1=F+H	MB+B+(Hx2)	DBOMH-12/20M	0.157	1/8"-27NTP
DV116X-08-MQBBN-12-CB	60362	1.000		12.00	11.20	8.00	4.00	0.125	0.157					
DV120X-08-MQBBN-15-CB	60364	1.250		15.00	14.20	10.00	5.00	0.250	0.195					
Metric		UPC No. 733101-	Carbide Body								Modular Head* CBBB	Coolant Bore Dia.	Coolant Attachment Thread	
Carbide Bar Description	Neutral		Boring Ratio	D	C	C1	L	C2	H	F1*	Min. Bore B**			
DVM20X-08-MQBBN-0240-CB	60366		8 x Dia.	20	240	219.68	160	80	0	F1=F+H	MB+B+(Hx2)	DBOMH-12/20M	4	1/8"-27NTP
DVM25X-08-MQBBN-0300-CB	60368	25		300	279.68	200	100	2.5	4					
DVM32X-08-MQBBN-0384-CB	60370	32		384	363.68	256	128	6	5					

*Modular heads sold separately, see pages D-70- D-77 for specifications.

Solution Tool!™ The NO! Vibration Tunable Boring Bar

DV_10_MQBBN_ Solution Tool!™ Thru Coolant Quick Change Modular Boring Bar Body

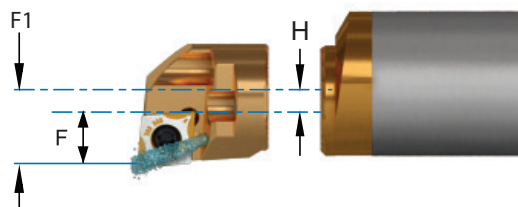
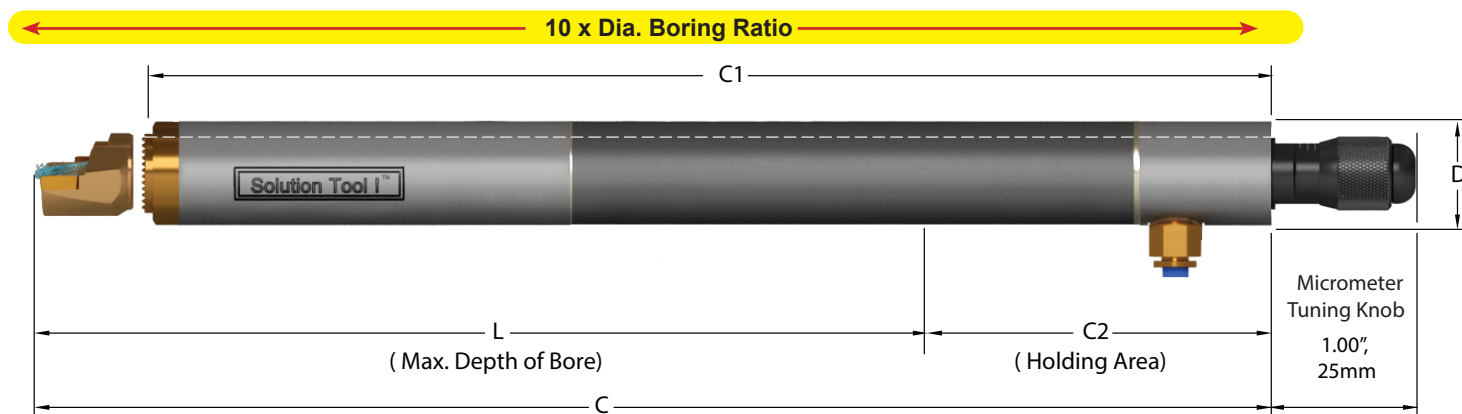

$$F1^* = F + H$$

$$\text{Min Bore} = B + (H \times 2)^*$$

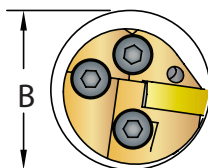

1. Coolant Inlet when Micrometer Tuning knob is connected to the Bar
2. 1/8" NTP Coolant Attachment when Micrometer Tuning knob is removed from the Bar
3. For blind boring bar, remove Micrometer Tuning knob and Coolant Attachment

Inch		UPC No. 733101-	Steel Body								Min. Bore B**	Modular Head* CBBB	Coolant Bore Dia.	Coolant Attachment Thread
Steel Bar Description	UPC No.	Neutral	Boring Ratio	D	C	C1	L	C2	H	F1*				
DVI12X-10-MQBBN-11-SB	59342		10 x Dia.	0.750	10.50	9.70	7.50	3.00	0	F1=F+H	MB+B+(Hx2)	DBOMH-12/20M	0.157	1/8"-27NTP
DVI16X-10-MQBBN-14-SB	59429			1.000	14.00	13.20	10.00	4.00	0.125					
DVI20X-10-MQBBN-18-SB	59471			1.250	17.50	16.70	12.50	5.00	0.250					
Metric		UPC No. 733101-	Steel Body								Min. Bore B**	Modular Head* CBBB	Coolant Bore Dia.	Coolant Attachment Thread
Steel Bar Description	UPC No.	Neutral	Boring Ratio	D	C	C1	L	C2	H	F1*				
DVM20X-10-MQBBN-0280-SB	59347		10 x Dia.	20	280	259.68	200	80	0	F1=F+H	MB+B+(Hx2)	DBOMH-12/20M	4	1/8"-27NTP
DVM25X-10-MQBBN-0350-SB	59431			25	350	329.68	250	100	2.5					
DVM32X-10-MQBBN-0448-SB	59472			32	448	427.68	320	128	6					
Inch		UPC No. 733101-	Carbide Body								Min. Bore B**	Modular Head* CBBB	Coolant Bore Dia.	Coolant Attachment Thread
Carbide Bar Description	UPC No.	Neutral	Boring Ratio	D	C	C1	L	C2	H	F1*				
DVI12X-10-MQBBN-11-CB	60361		10 x Dia.	0.750	10.50	9.70	7.50	3.00	0	F1=F+H	MB+B+(Hx2)	DBOMH-12/20M	0.157	1/8"-27NTP
DVI16X-10-MQBBN-14-CB	60363			1.000	14.00	13.20	10.00	4.00	0.125					
DVI20X-10-MQBBN-18-CB	60365			1.250	17.50	16.70	12.50	5.00	0.250					
Metric		UPC No. 733101-	Carbide Body								Min. Bore B**	Modular Head* CBBB	Coolant Bore Dia.	Coolant Attachment Thread
Carbide Bar Description	UPC No.	Neutral	Boring Ratio	D	C	C1	L	C2	H	F1*				
DVM20X-10-MQBBN-0280-CB	60367		10 x Dia.	20	280	259.68	200	80	0	F1=F+H	MB+B+(Hx2)	DBOMH-12/20M	4	1/8"-27NTP
DVM25X-10-MQBBN-0350-CB	60369			25	350	329.68	250	100	2.5					
DVM32X-10-MQBBN-0448-CB	60371			32	448	427.68	320	128	6					

*Modular heads sold separately, see pages D-70- D-77 for specifications.

Solution Tool!™ The NO! Vibration Tunable Boring Bar

DV_12_MQBBSN_Solution Tool!™ Thru Coolant Quick Change Modular Boring Bar Body

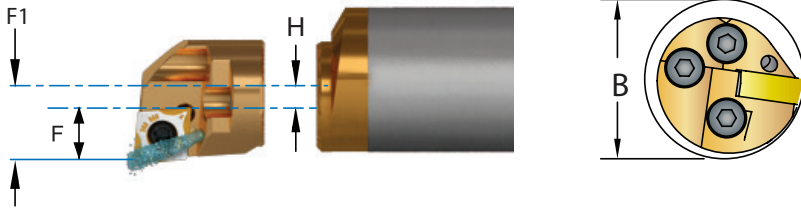
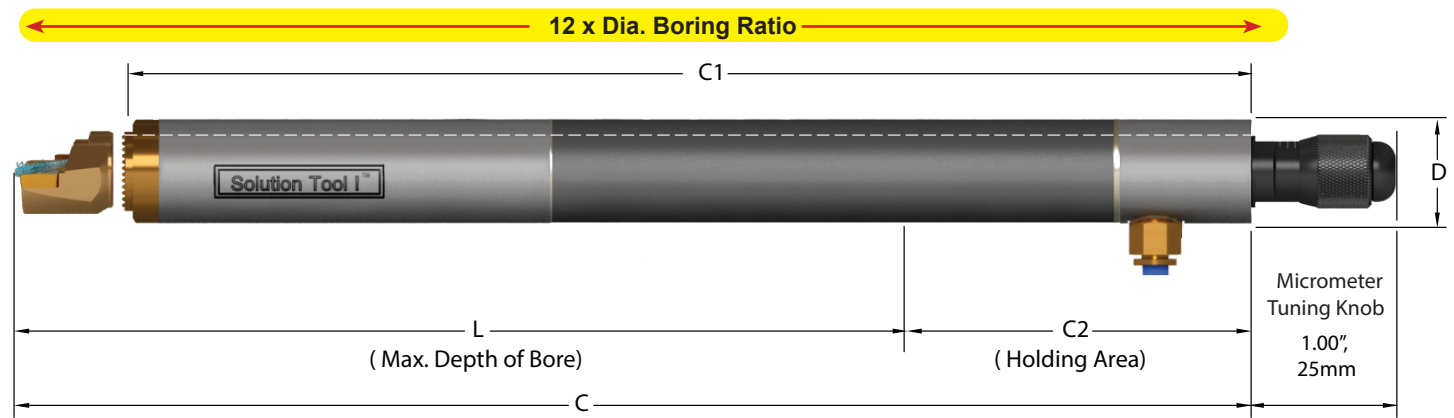

$F1^* = F + H$
 $Min\ Bore = B + (H \times 2)^*$

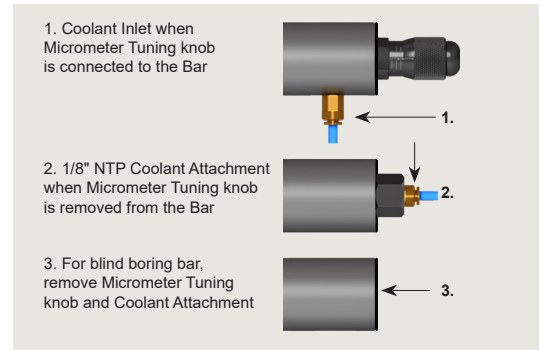

Inch		UPC No. 733101-	Steel Body								Min. Bore B**	Modular Head* CBBB	Coolant Bore Dia.	Coolant Attachment Thread
Carbide Bar Description	Neutral		Boring Ratio	D	C	C1	L	C2	H	F1*				
DV112X-12-MQBBSN-12-SB	59360		12 x Dia.	0.750	12.00	11.20	9.00	3.00	0	F1=F+H	MB+B+(Hx2)	DBOMH-12/20M	0.157	1/8"-27NTP
DV116X-12-MQBBSN-16-SB	59361	1.000		16.00	15.20	12.00	4.00	0.125	0.157					
DV120X-12-MQBBSN-20-SB	59362	1.250		20.00	19.20	15.00	5.00	0.250	0.195					
Metric		UPC No. 733101-	Steel Body								Min. Bore B**	Modular Head* CBBB	Coolant Bore Dia.	Coolant Attachment Thread
Carbide Bar Description	Neutral		Boring Ratio	D	C	C1	L	C2	H	F1*				
DVM20X-12-MQBBSN-0320-SB	59363		12 x Dia.	20	320	299.68	240	80	0	F1=F+H	MB+B+(Hx2)	DBOMH-12/20M	4	1/8"-27NTP
DVM25X-12-MQBBSN-0400-SB	59364	25		400	379.68	300	100	2.5	4					
DVM32X-12-MQBBSN-0512-SB	59365	32		512	491.68	384	128	6	5					
Inch		UPC No. 733101-	Carbide Body								Min. Bore B**	Modular Head* CBBB	Coolant Bore Dia.	Coolant Attachment Thread
Carbide Bar Description	Neutral		Boring Ratio	D	C	C1	L	C2	H	F1*				
DV112X-12-MQBBSN-12-CB	59343		12 x Dia.	0.750	12.00	11.20	9.00	3.00	0	F1=F+H	MB+B+(Hx2)	DBOMH-12/20M	0.157	1/8"-27NTP
DV116X-12-MQBBSN-16-CB	59391	1.000		16.00	15.20	12.00	4.00	0.125	0.157					
DV120X-12-MQBBSN-20-CB	59393	1.250		20.00	19.20	15.00	5.00	0.250	0.195					
Metric		UPC No. 733101-	Carbide Body								Min. Bore B**	Modular Head* CBBB	Coolant Bore Dia.	Coolant Attachment Thread
Carbide Bar Description	Neutral		Boring Ratio	D	C	C1	L	C2	H	F1*				
DVM20X-12-MQBBSN-0320-CB	59348		12 x Dia.	20	320	299.68	240	80	0	F1=F+H	MB+B+(Hx2)	DBOMH-12/20M	4	1/8"-27NTP
DVM25X-12-MQBBSN-0400-CB	59395	25		400	379.68	300	100	2.5	4					
DVM32X-12-MQBBSN-0512-CB	59397	32		512	491.68	384	128	6	5					

*Modular heads sold separately, see pages D-70- D-77 for specifications.



Solution Tool!™ The NO! Vibration Tunable Boring Bar

DV_14_MQBBN_Solution Tool!™ Thru Coolant Quick Change Modular Boring Bar Body

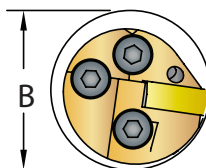
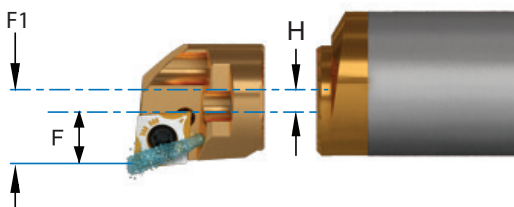
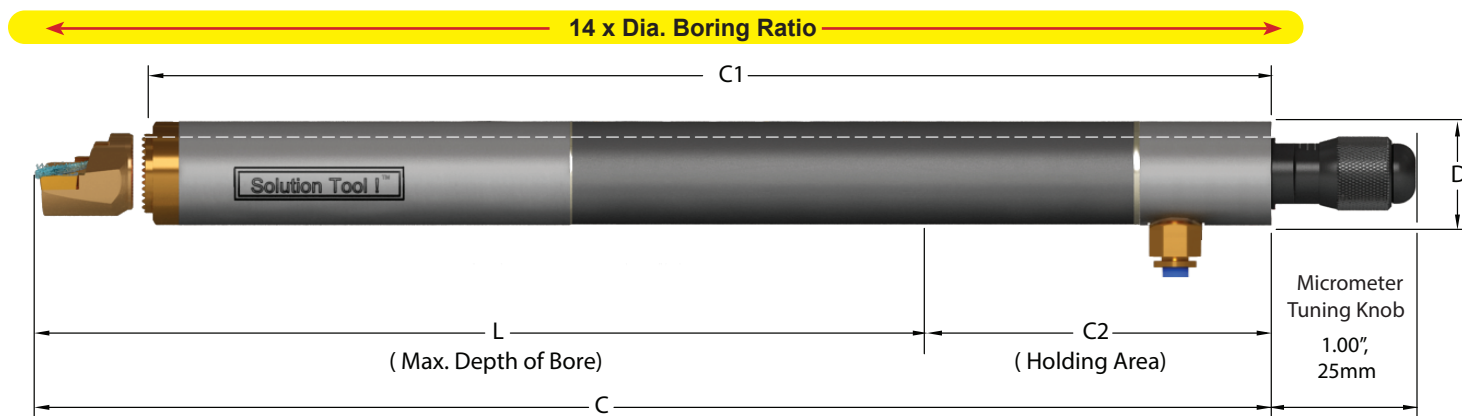

$F1^* = F + H$
 Min Bore = $B + (H \times 2)^*$

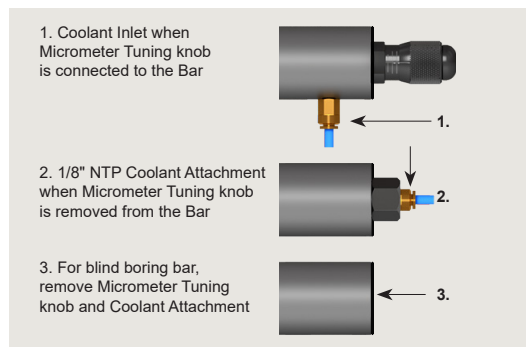

Inch		UPC No. 733101-	Carbide Body								Min. Bore B**	Modular Head* CBBB	Coolant Bore Dia.	Coolant Attachment Thread
Carbide Bar Description	UPC No.	Neutral	Boring Ratio	D	C	C1	L	C2	H	F1*				
DV112X-14-MQBBN-14-CB	59344		14 x Dia.	0.750	13.50	12.70	10.50	3.00	0	F1=F+H	MB+B+(Hx2)	DBOMH-12/20M	0.157	1/8"-27NTP
DV116X-14-MQBBN-18-CB	59392			1.000	18.00	17.20	14.00	4.00	0.125			0.157		
DV120X-14-MQBBN-23-CB	59394			1.250	22.50	21.70	17.50	5.00	0.250			0.195		
Metric		UPC No. 733101-	Carbide Body								Min. Bore B**	Modular Head* CBBB	Coolant Bore Dia.	Coolant Attachment Thread
Carbide Bar Description	UPC No.	Neutral	Boring Ratio	D	C	C1	L	C2	H	F1*				
DVM20X-14-MQBBN-0360-CB	59349		14 x Dia.	20	360	339.68	280	80	0	F1=F+H	MB+B+(Hx2)	DBOMH-12/20M	4	1/8"-27NTP
DVM25X-14-MQBBN-0450-CB	59396			25	450	429.68	350	100	2.5			4		
DVM32X-14-MQBBN-0576-CB	59398			32	576	555.68	448	128	6			5		

*Modular heads sold separately, see pages D-70- D-77 for specifications. One high pressure coolant connection kit supplied, see Page D-72 for details.

Solution Tool!™ The NO! Vibration Tunable Boring Bar

SCLC R/L Solution Tool!™ Thru Coolant Quick Change Modular Boring Head Style L- Negative 5° End & Side Cutting Edge Angle for 7° positive 80° diamond CC__ inserts

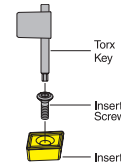
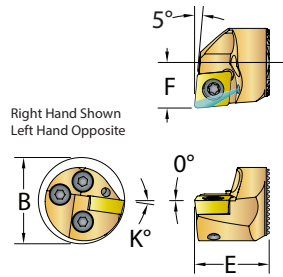
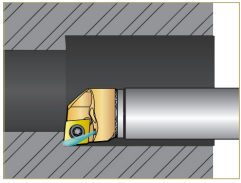

Thru Coolant

Head Description	UPC No. 733101-		B		E		F		K°	Reference Bars Dia.		CCMT Gage Insert		Insert Torx Screw	Torx Key
	R.H.	L.H.	Inch	Metric	Inch	Metric	Inch	Metric		Inch	Metric	Inch	Metric		
DBOMH-12/20M-SCLCR/L-3	60225	60226	1.000	26	0.820	20.83	0.500	12.70	8°	0.750	20	32.52	09T308	TS-4.7-10M1	T-15
			1.250	31	0.820	20.83	0.500	12.70	8°	1.000	25				
			1.500	38	0.820	20.83	0.500	12.70	8°	1.250	32				

Heads will fit both inch and metric boring bar shanks

SDNC R/L Solution Tool!™ Thru Coolant Quick Change Modular Boring Head Style N - Negative 27.5° End & Side Cutting Edge Angle for 7° positive 55° diamond DC__ inserts

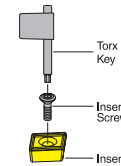
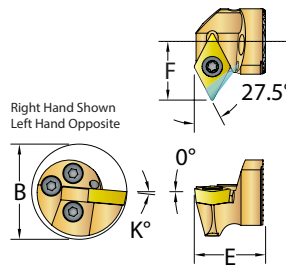
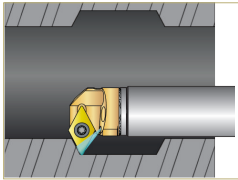

Thru Coolant

Head Description	UPC No. 733101-		B		E		F		K°	Reference Bars Dia.		DCMT Gage Insert		Insert Torx Screw	Torx Key
	R.H.	L.H.	Inch	Metric	Inch	Metric	Inch	Metric		Inch	Metric	Inch	Metric		
DBOMH-12/20M-SDNCR/L-3	60229	60230	1.160	30	0.820	20.83	0.660	16.76	5°	0.750	20	32.52	11T308	TS-4.7-10M1	T-15
			1.410	35	0.820	20.83	0.660	16.76	5°	1.000	25				
			1.660	42	0.820	20.83	0.660	16.76	5°	1.250	32				

Heads will fit both inch and metric boring bar shanks

Solution Tool!™ The NO! Vibration Tunable Boring Bar

SDQC R/L Solution Tool!™ Thru Coolant Quick Change Modular Boring Head Style Q - Negative 17.5° End & Side Cutting Edge Angle for 7° positive 55° diamond DC__ inserts

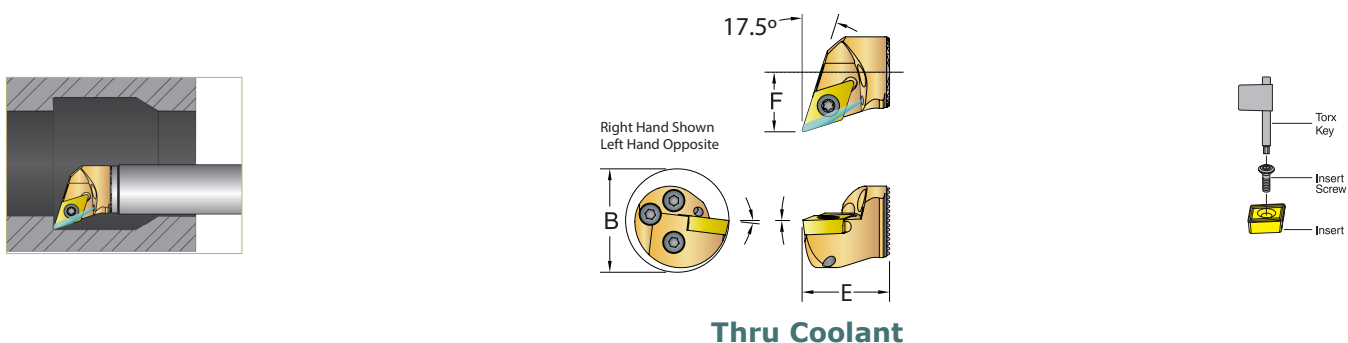

Thru Coolant

Head Description	UPC No. 733101-		B		E		F		K°	Reference Bars Dia.		DCMT Gage Insert		Insert Torx Screw	Torx Key
	R.H.	L.H.	Inch	Metric	Inch	Metric	Inch	Metric		Inch	Metric	Inch	Metric		
	DBOMH-12/20M-SDQCR/L-3	60231	60232	1.125	29	0.820	20.83	0.625		15.88	7°	0.750	20		
			1.375	34	0.820	20.83	0.625	15.88	7°	1.000	25				
			1.625	41	0.820	20.83	0.625	15.88	7°	1.250	32				

Heads will fit both inch and metric boring bar shanks

SDUC R/L Solution Tool!™ Thru Coolant Quick Change Modular Boring Head Style U - Negative 3° End & Side Cutting Edge Angle for 7° positive 55° diamond DC__ inserts

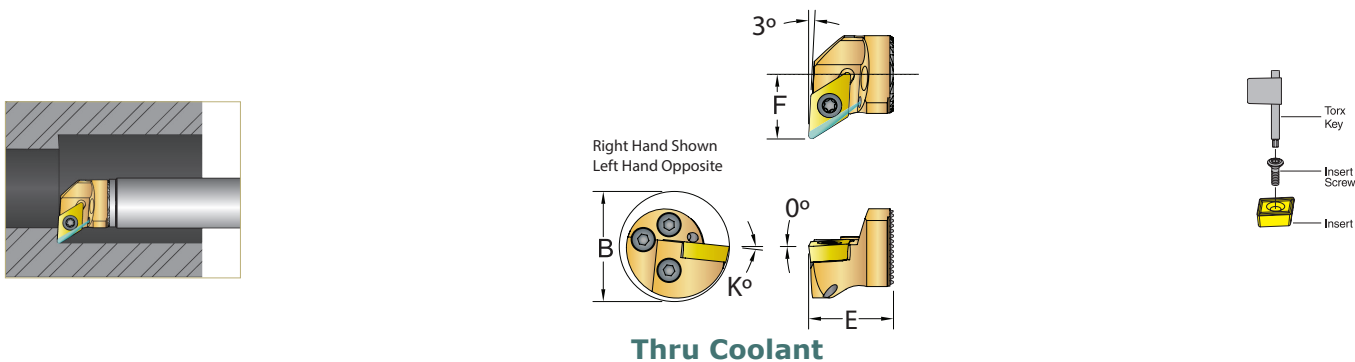

Thru Coolant

Head Description	UPC No. 733101-		B		E		F		K°	Reference Bars Dia.		DCMT Gage Insert		Insert Torx Screw	Torx Key
	R.H.	L.H.	Inch	Metric	Inch	Metric	Inch	Metric		Inch	Metric	Inch	Metric		
	DBOMH-12/20M-SDUCR/L-2	60247	60248	1.025	26	0.820	20.83	0.525		13.34	6°	0.750	20		
			1.275	27	0.820	20.83	0.525	13.34	6°	1.000	25				
			1.525	38	0.820	20.83	0.525	13.34	6°	1.250	32				
DBOMH-12/20M-SDUCR/L-3	60227	60228	1.038	26.37	0.820	20.83	0.625	15.88	6°	0.750	20	32.52	11T308	TS-4.7-10M1	T-15
			1.278	32.46	0.820	20.83	0.745	18.92	6°	1.000	25				
			1.538	39.07	0.820	20.83	0.880	22.35	6°	1.250	32				

Heads will fit both inch and metric boring bar shanks

Solution Tool!™ The NO! Vibration Tunable Boring Bar

SDXC R/L Solution Tool!™ Thru Coolant Quick Change Modular Boring Head Style X - Negative 5° Back Boring Cutting Edge Angle for 7° positive 55° diamond DC__ inserts

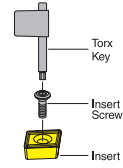
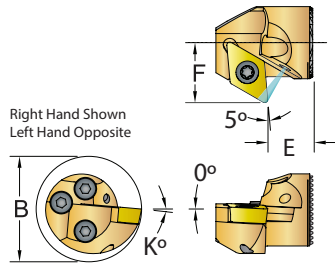
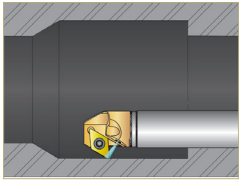

Thru Coolant

Head Description	UPC No. 733101-		B		E		F		K°	Reference Bars Dia.		DCMT Gage Insert		Insert Torx Screw	Torx Key
	R.H.	L.H.	Inch	Metric	Inch	Metric	Inch	Metric		Inch	Metric	Inch	Metric		
	DBOMH-12/20M-SDXCR/L-3	60233	60234	1.025	26	0.820	20.83	0.525		13.34	5°	0.750	20		
			1.275	27	0.820	20.83	0.525	13.34	5°	1.000	25				
			1.525	38	0.820	20.83	0.525	13.34	5°	1.250	32				

Heads will fit both inch and metric boring bar shanks

STUC R/L Solution Tool!™ Thru Coolant Quick Change Modular Boring Head Style U - Negative 3° End Cutting Edge Angle for 7° positive triangle TC__ inserts

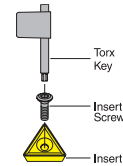
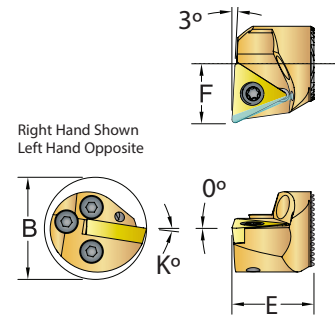
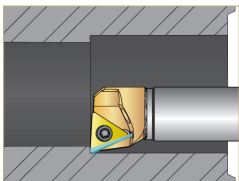

Thru Coolant

Head Description	UPC No. 733101-		B		E		F		K°	Reference Bars Dia.		TCMT Gage Insert		Insert Torx Screw	Torx Key
	R.H.	L.H.	Inch	Metric	Inch	Metric	Inch	Metric		Inch	Metric	Inch	Metric		
	DBOMH-12/20M-STUCR/L-2	60255	60256	1.000	26	0.820	20.83	0.500		12.70	6°	0.750	20		
			1.250	31	0.820	20.83	0.500	12.70	6°	1.000	25				
			1.500	38	0.820	20.83	0.500	12.70	6°	1.250	32				
DBOMH-12/20M-STUCR/L-3	60235	60236	1.090	28	0.820	20.83	0.590	14.99	9°	0.750	20	32.52	16T308	TS-4.7-10M1	T-15
			1.340	33	0.820	20.83	0.590	14.99	9°	1.000	25				
			1.590	40	0.820	20.83	0.590	14.99	9°	1.250	32				

Heads will fit both inch and metric boring bar shanks

Solution Tool!™ The NO! Vibration Tunable Boring Bar

SVUC R/L Solution Tool!™ Thru Coolant Quick Change Modular Boring Head Style U - Negative 3° End Cutting Edge Angle for 7° positive 35° diamond VC__ inserts

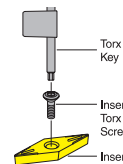
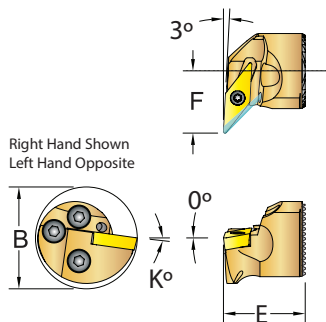
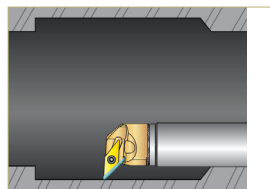

Thru Coolant

Head Description	UPC No. 733101-		B		E		F		K°	Reference Bars Dia.		VCMT Gage Insert		Insert Torx Screw	Torx Key
	R.H.	L.H.	Inch	Metric	Inch	Metric	Inch	Metric		Inch	Metric	Inch	Metric		
	DBOMH-12/20M-SVUCR/L-2	60237	60238	1.125	29	0.820	20.83	0.625		15.88	8°	0.750	20		
			1.375	34	0.820	20.83	0.625	15.88	8°	1.000	25				
			1.625	41	0.820	20.83	0.625	15.88	8°	1.250	32				

Heads will fit both inch and metric boring bar shanks

SWLC R/L Solution Tool!™ Thru Coolant Quick Change Modular Boring Head Style L - Negative 5° End Cutting Edge Angle for 7° positive 80° trigon WC__ inserts

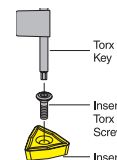
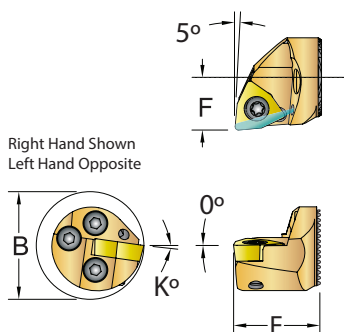
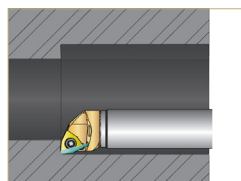

Thru Coolant

Head Description	UPC No. 733101-		B		E		F		K°	Reference Bars Dia.		WCMT Gage Insert		Insert Torx Screw	Torx Key
	R.H.	L.H.	Inch	Metric	Inch	Metric	Inch	Metric		Inch	Metric	Inch	Metric		
	DBOMH-12/20M-SWLCR/L-3	60241	60242	1.000	26	0.820	20.83	0.500		12.70	8°	0.750	20		
			1.250	31	0.820	20.83	0.500	12.70	8°	1.000	25				
			1.500	38	0.820	20.83	0.500	12.70	8°	1.250	32				

Heads will fit both inch and metric boring bar shanks

Solution Tool!™ The NO! Vibration Tunable Boring Bar

SN R/L Solution Tool!™ Thru Coolant Quick Change Modular Threading Head for Laydown Inserts

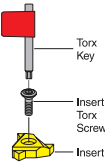
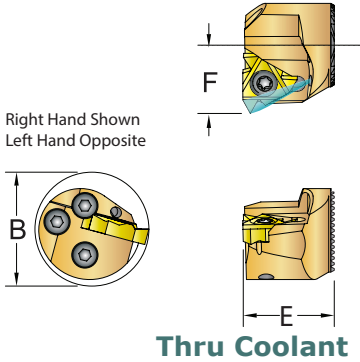
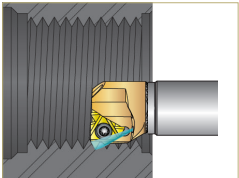

Head Description	UPC No. 733101-		B		E		F		Reference Bars Dia.		Laydown Gage Insert		Insert Torx Screw	Torx Key
	R.H.	L.H.	Inch	Metric	Inch	Metric	Inch	Metric	Inch	Metric	Inch	Metric		
DBOMH-12/20M-SNR/L-16	60243	60244	1.125	29	0.820	20.83	0.625	15.88	0.750	20	16-A60	16-A60	TS-35.6-9M1	T-15
			1.375	34	0.820	20.83	0.625	15.88	1.000	25				
			1.625	41	0.820	20.83	0.625	15.88	1.250	32				

Heads will fit both inch and metric boring bar shanks



Solution Tool!™ The NO! Vibration Tunable Boring Bar

Solution Tool!™ Thru Coolant Jet-Stream™ Modular Boring Bars

The NO! Vibration Tunable Boring Bar for Multi Boring and Threading Applications on Large Diameter Holes

Makes Deep Hole Boring Simple!

The Modular Jet-Stream™ Bar is Supplied with the Jet-Stream™ Thru Coolant System To Improve Performance!

At a close range of 1/4" (6mm) the Jet-Stream™ coolant system aims the coolant precisely onto the cutting edge of the insert at a very high velocity.

The controlled Jet-Stream™ coolant will lubricate the cutting edge of the insert reducing the coefficient of friction, stopping the chip from adhering to the insert.

The physical combination of high velocity and high pressure forces the hot chip to hydroplane away from the cutting edge of the insert.

As a result, the insert will operate at a constant low temperature,
With a clean and undamaged cutting edge,
changing the way metal is cut!

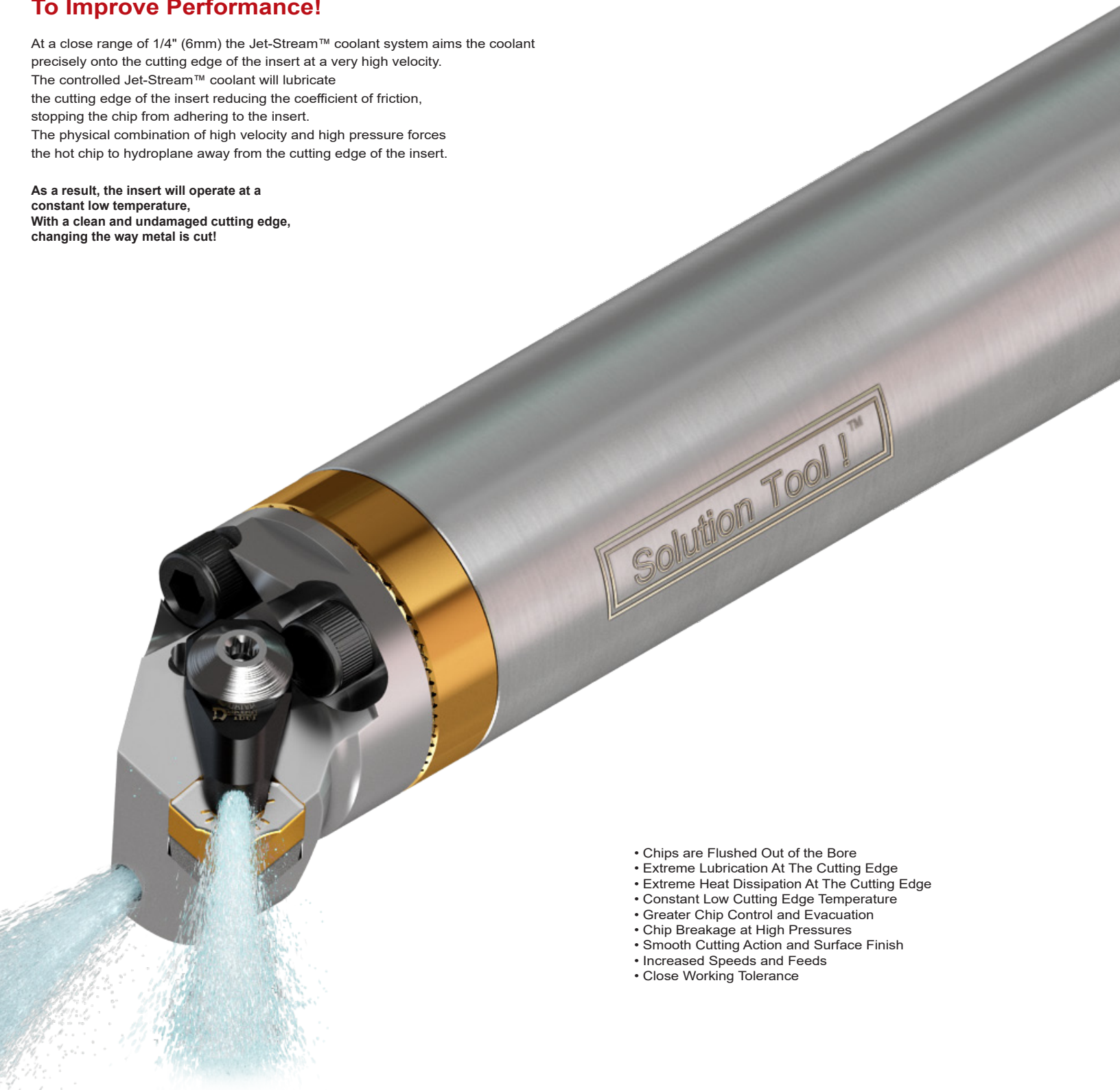

- Chips are Flushed Out of the Bore
- Extreme Lubrication At The Cutting Edge
- Extreme Heat Dissipation At The Cutting Edge
- Constant Low Cutting Edge Temperature
- Greater Chip Control and Evacuation
- Chip Breakage at High Pressures
- Smooth Cutting Action and Surface Finish
- Increased Speeds and Feeds
- Close Working Tolerance

Solution Tool!™ The NO! Vibration Tunable Boring Bar

Solution Tool!™

The NO! Vibration Tunable Boring Bar
Makes Deep Hole Boring Simple!

SIMPLE - PRECISE - RIGID - POWERFUL

Thru Coolant Jet-Stream™ Modular Boring Bars

The NO! Vibration Tunable Boring Bar for Large Boring Operation.
Engineered for multi boring and threading applications on large diameter holes,
and cutting depth to 14 x Boring Bar Diameter

Multi Boring and Threading Applications

Better Machining Performance

Higher Workmanship Quality

Longer Cutting Insert Life

The technology behind the Solution Tool!™ the "Modular" NO! Vibration Tunable Boring Bars, is to perform simple, precise and reliable when deep boring large sizes holes, with close machining tolerance and high surface finish, in multi boring and threading applications.

The "Modular" NO! Vibration Tunable Boring Bars, is a two part construction. The body where the boring bar is held, and the housing that holds the dampener, and brazed together with Silver Alloy. The braze is the buffer zone where the frequencies generate from the cutting operation are stopped.

To maximize performance in deep boring operation, the "Modular Body" is Offered in two versions;

Steel Body

The steel body for boring depth up to 12 x Boring Bar Diameter

Carbide Body

The carbide body rigidity, stability, and strength, allows to bore at higher cutting rate, heavier material removal, longer depth of cut, close working tolerances and higher surface finish.

Boring Bar Sizes

Inch: 1 1/2" Dia., 1 1/3" Dia. 2" Dia.,
2 1/2" Dia., 3" Dia., 4" Dia.,
Metric: 40mm Dia., 50mm Dia., 60mm Dia.,
80mm Dia., 100mm Dia.,

Boring Ratio: 8 x Dia., 10 x Dia., 12 x Dia., 14 x Dia.

Positive Insert Geometry:

for Modular Head:
CCMT DCMT TCMT VCCT

Threading Lay-Down Insert:

16-A60 22-N60



Coolant Inlet

Micrometer Tuning Knob

Allows to fine tune the mechanical dampener at a precise position. Neutralize the boring bar frequencies with no vibration while boring for a smooth surface finish and close tolerances. Can be removed and replaced with a coolant inlet.

Body

Offered in two versions
Steel Body; up to 12 x Dia. Boring depth.
Carbide Body; for higher boring performance over the Steel body.

Braze Connection

Connects the boring bar body with the housing, the combination of the correct silver alloy and the thickness of the braze makes brazing strong and unbreakable, but flexible under the cutting pressure and interrupt cuts, and creating a buffer zone that increases damping to stop the frequencies developed in the boring operation.

Dampener Position Locking Screw

The screw is released before re-tuning and locked after tuning is complete.

Housing

Made of heat treated alloy steel, brazed with the body, the inside of the housing holds the mechanical dampener and on the face is attached the Quick Change Modular Collar Head.

Modular Head

Made of heat treated alloy steel and TiN Coated. Locks onto 60° serrated face of the collar face with three cup screws precisely and rigid, making interchangeability easy and quick. The Thru Coolant System enhances boring performance, quality and longer insert life. The insert is kept at constant temperature clean and undamaged cutting edge, and removes chips from the bore while machining.

Modular Head Collar

Made of heat treated alloy steel and TiN Coated. Precisely and rigid attaches on to the housing face. The face of the Collar, has a 60° serrated groove to expand the surface contact with the Quick Change Heads, for maximum locking rigidity and precise interchangeability.

Solution Tool!™ Thru Coolant Jet-Stream™ Modular Boring Body & Head

The NO! Vibration Tunable Boring Bar for Multi Boring and Threading Applications on Large Diameter Holes

Makes Deep Hole Boring Simple!

1 ADCLN
R/L Modular
Boring Bar Head
With Thru Coolant

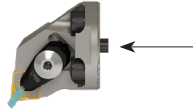

2 ADDQN
R/L Modular
Boring Bar Head
With Thru Coolant

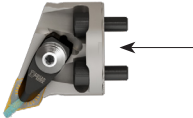

3 ADDUN
R/L Modular
Boring Bar Head
With Thru Coolant

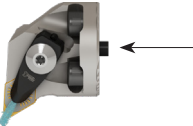

4 ADTUN
R/L Modular
Boring Bar Head
With Thru Coolant

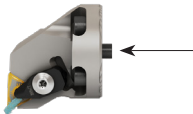

5 ADVUN
R/L Modular
Boring Bar Head
With Thru Coolant

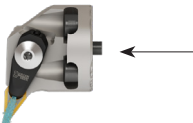

6 ADWLN
R/L Modular
Boring Bar Head
With Thru Coolant

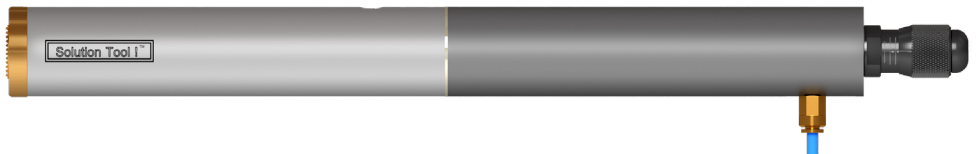
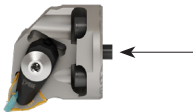

7 ASCLC
R/L Modular
Boring Bar Head
With Thru Coolant

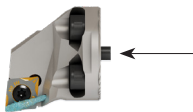

One Modular
Carbide or Steel Body

8 ASDQC
R/L Modular
Boring Bar Head
With Thru Coolant

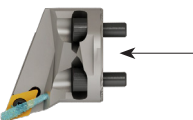

Fourteen
Interchangeable Heads

9 ASDUC
R/L Modular
Boring Bar Head
With Thru Coolant

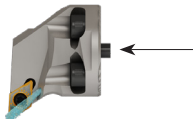

12 ADLN
R/L Modular
Threading Bar Head
With Thru Coolant

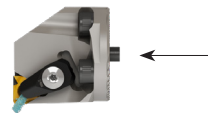

10 ASTUC
R/L Modular
Boring Bar Head
With Thru Coolant

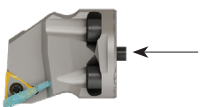

13 ADNE
R/L Modular
Threading Bar Head
With Thru Coolant

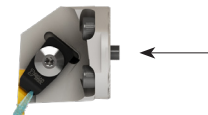

11 ASVUC
R/L Modular
Boring Bar Head
With Thru Coolant

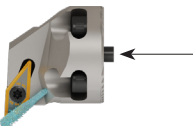

14 ADTHO
R/L Modular
Threading Bar Head
With Thru Coolant

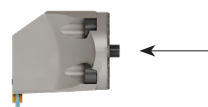

Solution Tool!™ The NO! Vibration Tunable Boring Bar

Thru Coolant Jet-Stream™ Modular Boring Bar Body

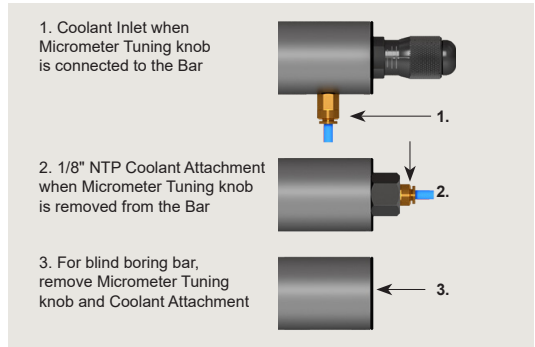
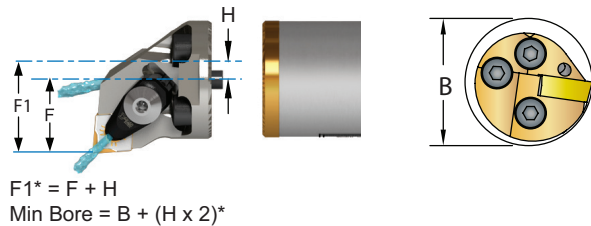
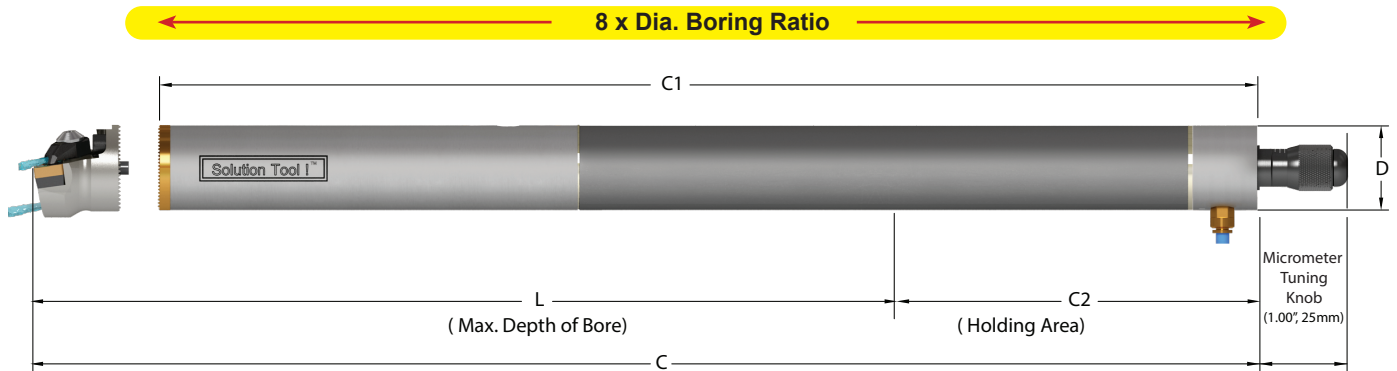

Inch	UPC No. 733101- Neutral	Boring Ratio	Steel Body							Min. Bore B**	Modular Head* CBBB	Coolant Bore Dia.	Coolant Attachment Thread
			D	C	C1	L	C2	H	F1*				
ASI24X-8-DVI-MBBB-18-SB	59321	8 x Dia.	1.500	18.000	16.500	12.000	6.000	0	F1=F+H	MB+B+(Hx2)	DBOMH24/40_A_R/L	0.250	1/4"-18NTP
ASI28X-8-DVI-MBBB-21-SB	59322		1.750	21.000	19.500	14.000	7.000	0.125				0.250	
ASI32X-8-DVI-MBBB-24-SB	59323		2.000	24.000	22.500	16.000	8.000	0.250				0.312	
ASI40X-8-DVI-MBBB-30-SB	59324		2.500	30.000	28.500	20.000	10.000	0.500				0.375	
ASI48X-8-DVI-MBBB-36-SB	59325		3.000	36.000	34.500	24.000	12.000	0.750				0.375	
ASI64X-8-DVI-MBBB-48-SB	59326		4.000	48.000	46.500	32.000	16.000	1.250				0.375	

Metric	UPC No. 733101- Neutral	Boring Ratio	Steel Body							Min. Bore B**	Modular Head* CBBB	Coolant Bore Dia.	Coolant Attachment Thread
			D	C	C1	L	C2	H	F1*				
ASM40X-8-DVI-MBBB-0480-SB	59328	8 x Dia.	40	480	442	320	160	0	F1=F+H	MB+B+(Hx2)	DBOMH24/40_A_R/L	6	1/4"-18NTP
ASM50X-8-DVI-MBBB-0600-SB	59329		50	600	562	400	200	5				6	
ASM60X-8-DVI-MBBB-0720-SB	59330		60	720	682	480	240	10				8	
ASM80X-8-DVI-MBBB-0960-SB	59331		80	960	922	640	320	20				10	
ASM100X-8-DVI-MBBB-1200-SB	59332		100	1200	1162	800	400	30				10	

One high pressure coolant connection kit supplied, see Page D-94 for details.

Solution Tool!™ The NO! Vibration Tunable Boring Bar

Thru Coolant Jet-Stream™ Modular Boring Bar Body

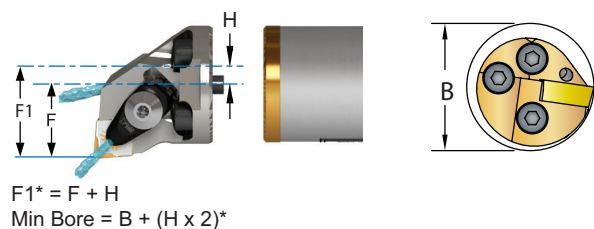
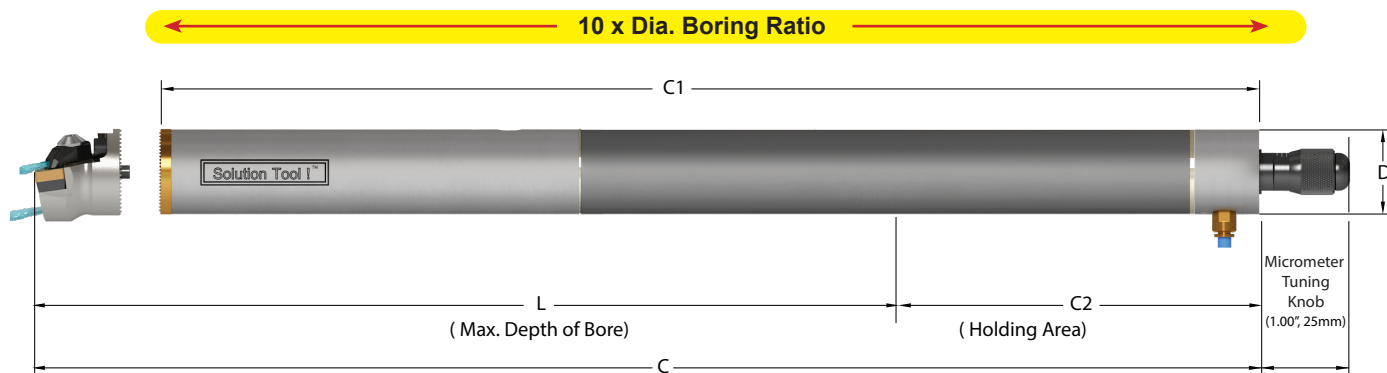

1. Coolant Inlet when Micrometer Tuning knob is connected to the Bar

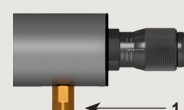

2. 1/8" NTP Coolant Attachment when Micrometer Tuning knob is removed from the Bar

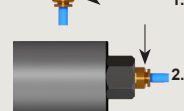

3. For blind boring bar, remove Micrometer Tuning knob and Coolant Attachment



Inch	UPC No. 733101- Neutral	Boring Ratio	Steel Body							Min. Bore B**	Modular Head* CBBB	Coolant Bore Dia.	Coolant Attachment Thread
			D	C	C1	L	C2	H	F1*				
ASI24X-10-DVI-MBBB-21-SB	59433	10 x Dia.	1.500	21.000	19.500	15.000	6.000	0	F1=F+H	MB+B+(Hx2)	DBOMH24/40_A_R/L	0.250	1/4"-18NTP
ASI28X-10-DVI-MBBB-25-SB	59434		1.750	24.500	23.000	17.500	7.000	0.125				0.250	
ASI32X-10-DVI-MBBB-28-SB	59435		2.000	28.000	26.500	20.000	8.000	0.250				0.312	
ASI40X-10-DVI-MBBB-35-SB	59436		2.500	35.000	33.500	25.000	10.000	0.500				0.375	
ASI48X-10-DVI-MBBB-42-SB	59437		3.000	42.000	40.500	30.000	12.000	0.750				0.375	
ASI64X-10-DVI-MBBB-56-SB	59438		4.000	56.000	54.500	40.000	16.000	1.250				0.375	

Metric	UPC No. 733101- Neutral	Boring Ratio	Steel Body							Min. Bore B**	Modular Head* CBBB	Coolant Bore Dia.	Coolant Attachment Thread
			D	C	C1	L	C2	H	F1*				
ASM40X-10-DVI-MBBB-0560-SB	59440	10 x Dia.	40	560	522	400	160	0	F1=F+H	MB+B+(Hx2)	DBOMH24/40_A_R/L	6	1/4"-18NTP
ASM50X-10-DVI-MBBB-0700-SB	59441		50	700	662	500	200	5				6	
ASM60X-10-DVI-MBBB-0840-SB	59442		60	840	802	600	240	10				8	
ASM80X-10-DVI-MBBB-1120-SB	59443		80	1120	1082	800	320	20				10	
ASM100X-10-DVI-MBBB-1400-SB	59444		100	1400	1362	1000	400	30				10	

One high pressure coolant connection kit supplied, see Page D-94 for details.

Solution Tool!™ The NO! Vibration Tunable Boring Bar

Thru Coolant Jet-Stream™ Modular Boring Bar Body

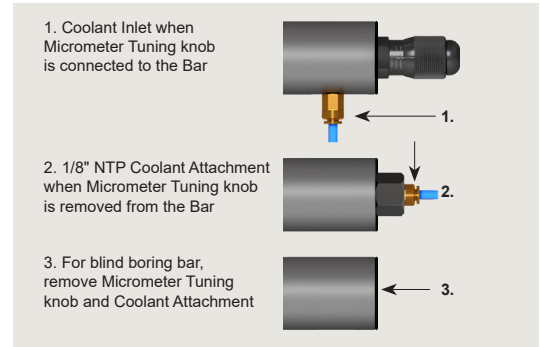
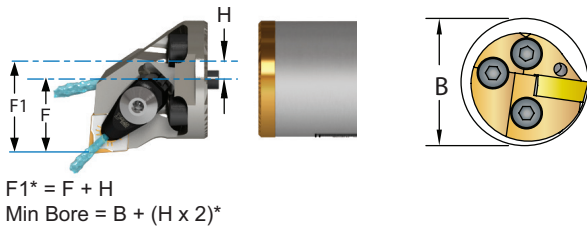
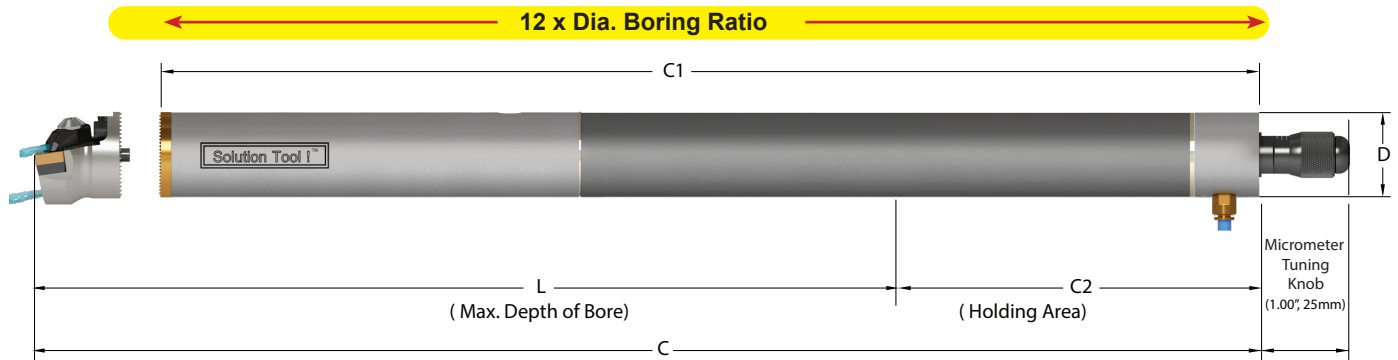

Inch	UPC No. 733101- Neutral	Boring Ratio	Steel Body					F1*	Min. Bore B**	Modular Head* CBBB	Coolant Bore Dia.	Coolant Attachment Thread
			D	C	C1	L	C2					
ASI24X-12-DVI-MBBB-24-SB	59446	12 x Dia.	1.500	24.000	22.500	18.000	6.000	0	F1=F+H	MB+B+(Hx2)	DBOMH24/40_A_R/L	0.250
ASI28X-12-DVI-MBBB-28-SB	59447		1.750	28.000	26.500	21.000	7.000	0.125				0.250
ASI32X-12-DVI-MBBB-32-SB	59448		2.000	32.000	30.500	24.000	8.000	0.250				0.312
ASI40X-12-DVI-MBBB-40-SB	59449		2.500	40.000	38.500	30.000	10.000	0.500				0.375
ASI48X-12-DVI-MBBB-48-SB	59450		3.000	48.000	46.500	36.000	12.000	0.750				0.375
ASI64X-12-DVI-MBBB-64-SB	59451		4.000	64.000	62.500	48.000	16.000	1.250				0.375

Metric	UPC No. 733101- Neutral	Boring Ratio	Steel Body					F1*	Min. Bore B**	Modular Head* CBBB	Coolant Bore Dia.	Coolant Attachment Thread
			D	C	C1	L	C2					
ASM40X-12-DVI-MBBB-0640-SB	59453	12 x Dia.	40	640	602	480	160	0	F1=F+H	MB+B+(Hx2)	DBOMH24/40_A_R/L	6
ASM50X-12-DVI-MBBB-0800-SB	59454		50	800	762	600	200	5				6
ASM60X-12-DVI-MBBB-0960-SB	59455		60	960	922	720	240	10				8
ASM80X-12-DVI-MBBB-1280-SB	59456		80	1280	1242	960	320	20				10
ASM100X-12-DVI-MBBB-1600-SB	59457		100	1600	1562	1200	400	30				10

Inch	UPC No. 733101- Neutral	Boring Ratio	Carbide Body					F1*	Min. Bore B**	Modular Head* CBBB	Coolant Bore Dia.	Coolant Attachment Thread
			D	C	C1	L	C2					
ASI24X-12-DVI-MBBB-24-CB	60349	12 x Dia.	1.500	24.000	22.500	18.000	6.000	0	F1=F+H	MB+B+(Hx2)	DBOMH24/40_A_R/L	0.250
ASI28X-12-DVI-MBBB-28-CB	60350		1.750	28.000	26.500	21.000	7.000	0.125				0.250
ASI32X-12-DVI-MBBB-32-CB	60351		2.000	32.000	30.500	24.000	8.000	0.250				0.312
ASI40X-12-DVI-MBBB-40-CB	60352		2.500	40.000	38.500	30.000	10.000	0.500				0.375
ASI48X-12-DVI-MBBB-48-CB	60353		3.000	48.000	46.500	36.000	12.000	0.750				0.375
ASI64X-12-DVI-MBBB-64-CB	60354		4.000	64.000	62.500	48.000	16.000	1.250				0.375

Metric	UPC No. 733101- Neutral	Boring Ratio	Carbide Body					F1*	Min. Bore B**	Modular Head* CBBB	Coolant Bore Dia.	Coolant Attachment Thread
			D	C	C1	L	C2					
ASM40X-12-DVI-MBBB-0640-CB	60355	12 x Dia.	40	640	602	480	160	0	F1=F+H	MB+B+(Hx2)	DBOMH24/40_A_R/L	6
ASM50X-12-DVI-MBBB-0800-CB	60356		50	800	762	600	200	5				6
ASM60X-12-DVI-MBBB-0960-CB	60357		60	960	922	720	240	10				8
ASM80X-12-DVI-MBBB-1280-CB	60358		80	1280	1242	960	320	20				10
ASM100X-12-DVI-MBBB-1600-CB	60359		100	1600	1562	1200	400	30				10

One high pressure coolant connection kit supplied, see Page D-94 for details.

Solution Tool!™ The NO! Vibration Tunable Boring Bar

Thru Coolant Jet-Stream™ Modular Boring Bar Body

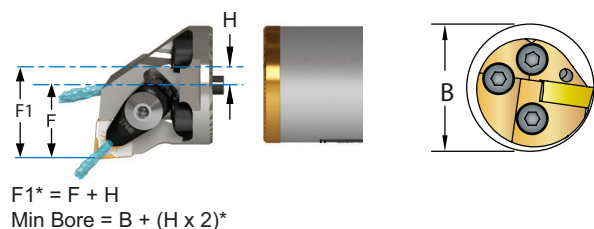
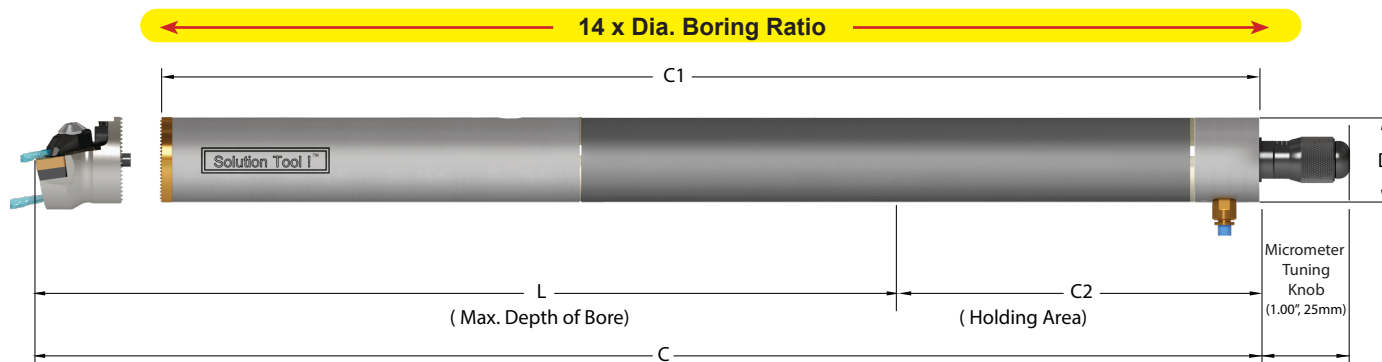

1. Coolant Inlet when Micrometer Tuning knob is connected to the Bar

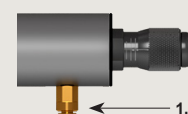

2. 1/8" NTP Coolant Attachment when Micrometer Tuning knob is removed from the Bar

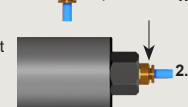

3. For blind boring bar, remove Micrometer Tuning knob and Coolant Attachment



Inch	UPC No. 733101- Neutral	Boring Ratio	Carbide Body							Min. Bore B*	Modular Head CBBB	Coolant Bore Dia.	Coolant Attachment Thread	
			D	C	C1	L	C2	H	F1*					
ASI24X-14-DVI-MBBB-27-CB	59459	14 x Dia.	1.500	27.000	25.500	21.000	6.000	0	F1=F+H	See head specifications	DBOMH24/40_A_R/L	0.250	1/4"-18NTP	
ASI28X-14-DVI-MBBB-32-CB	59460		1.750	31.500	30.000	24.500	7.000	0.125				0.250		
ASI32X-14-DVI-MBBB-36-CB	59461		2.000	36.000	34.500	28.000	8.000	0.250				0.312		
ASI40X-14-DVI-MBBB-45-CB	59462		2.500	45.000	43.500	35.000	10.000	0.500				0.375		
ASI48X-14-DVI-MBBB-54-CB	59463		3.000	54.000	52.500	42.000	12.000	0.750				0.375		1/4"-18NTP
ASI64X-14-DVI-MBBB-72-CB	59464		4.000	72.000	70.500	56.000	16.000	1.250				0.375		

Metric	UPC No. 733101- Neutral	Boring Ratio	Carbide Body							Min. Bore B*	Modular Head CBBB	Coolant Bore Dia.	Coolant Attachment Thread	
			D	C	C1	L	C2	H	F1*					
ASM40X-14-DVI-MBBB-0720-CB	59466	14 x Dia.	40	720	682	560	160	0	F1=F+H	See head specifications	DBOMH24/40_A_R/L	6	1/4"-18NTP	
ASM50X-14-DVI-MBBB-0900-CB	59467		50	900	862	700	200	5				6		
ASM60X-14-DVI-MBBB-1080-CB	59468		60	1080	1042	840	240	10				6		
ASM80X-14-DVI-MBBB-1440-CB	59469		80	1440	1402	1120	320	20				8		
ASM100X-14-DVI-MBBB-1800-CB	59470		100	1800	1762	1400	400	30				10		1/4"-18NTP

One high pressure coolant connection kit supplied, see Page D-94 for details.

Solution Tool!™ The NO! Vibration Tunable Boring Bar

UPC No.	Solution Tool! Boring Bar Part Number	UPC No.	Boring Ratio	D	F1	MB	Lenght of Cut	C2	C	Boring Head Part No.	Inserg Gage	Insert Torx Screw	Insert Torx Key
SolutionTool!™	Solution Tool! Steel Boring Bar™			SCLCR-3 Boring			CCMT-32.52 Insert			Inch Size			
73310159428	STI12X-08-QCBB-9-SB-SCLCR-3	50000	8	0.750	0.500	1.125	6.00	3.00	9.00	DBOMH-12/20M-SCLCR-3	CCMT-32.52	TS-4.7-10M1	T-15
73310159342	STI12X-10-QCBB-11-SB-SCLCR-3	50001	10	0.750	0.500	1.125	7.50	3.00	10.50				
73310159360	STI12X-12-QCBB-13-SB-SCLCR-3	50002	12	0.750	0.500	1.125	9.00	3.00	12.00				
73310159340	STI16X-08-QCBB-12-SB-SCLCR-3	50003	8	1.000	0.625	1.375	8.00	4.00	12.00	DBOMH-12/20M-SCLCR-3	CCMT-32.52	TS-4.7-10M1	T-15
73310159429	STI16X-10-QCBB-14-SB-SCLCR-3	50004	10	1.000	0.625	1.375	10.00	4.00	14.00				
73310159361	STI16X-12-QCBB-16-SB-SCLCR-3	50005	12	1.000	0.625	1.375	12.00	4.00	16.00				
73310159341	STI20X-08-QCBB-15-SB-SCLCR-3	50006	8	1.250	0.750	1.625	10.00	5.00	15.00	DBOMH-12/20M-SCLCR-3	CCMT-32.52	TS-4.7-10M1	T-15
73310159471	STI20X-10-QCBB-18-SB-SCLCR-3	50007	10	1.250	0.750	1.625	12.50	5.00	17.50				
73310159362	STI20X-12-QCBB-20-SB-SCLCR-3	50008	12	1.250	0.750	1.625	15.00	5.00	20.00				

UPC No.	Solution Tool! Boring Bar Part Number	UPC No.	Boring Ratio	D	F1	MB	Lenght of Cut	C2	C	Boring Head Part No.	Inserg Gage	Insert Torx Screw	Insert Torx Key
SolutionTool!™	Solution Tool! Steel Boring Bar™			SCLCR-3 Boring			CCMT-32.52 Insert			Inch Size			
73310159428	STI12X-08-QCBB-9-SB-SDUCR-2	50009	8	0.750	0.525	1.175	6.00	3.00	9.00	DBOMH-12/20M-SDUCR2	DCMT-21.51	TS-25.45.6M2	T-8
73310159342	STI12X-10-QCBB-11-SB-SDUCR-2	50010	10	0.750	0.525	1.175	7.50	3.00	10.50				
73310159360	STI12X-12-QCBB-13-SB-SDUCR-2	50011	12	0.750	0.525	1.175	9.00	3.00	12.00				
73310159340	STI16X-08-QCBB-12-SB-SDUCL-3	50012	8	1.000	0.650	1.425	8.00	4.00	12.00	DBOMH-12/20M-SDLCR-3	DCMT-32.52	TS-4.7-10M1	T-15
73310159429	STI16X-10-QCBB-14-SB-SDUCR-3	50013	10	1.000	0.650	1.425	10.00	4.00	14.00				
73310159361	STI16X-12-QCBB-16-SB-SDUCR-3	50014	12	1.000	0.650	1.425	12.00	4.00	16.00				
73310159341	STI20X-08-QCBB-15-SB-SDUCR-3	50015	8	1.250	0.775	1.675	10.00	5.00	15.00	DBOMH-12/20M-SDLCR-3	DCMT-32.52	TS-4.7-10M1	T-15
73310159471	STI20X-10-QCBB-18-SB-SDUCR3	50016	10	1.250	0.775	1.675	12.50	5.00	17.50				
73310159362	STI20X-12-QCBB-20-SB-SDUCR-3	50017	12	1.250	0.775	1.675	15.00	5.00	20.00				

UPC No.	Solution Tool! Boring Bar Part Number	UPC No.	Boring Ratio	D	F1	MB	Lenght of Cut	C2	C	Boring Head Part No.	Inserg Gage	Insert Torx Screw	Insert Torx Key
SolutionTool!™	Solution Tool! Steel Boring Bar™			SCLCR-3 Boring			CCMT-32.52 Insert			Inch Size			
73310159428	STI12X-08-QCBB-9-SB-STUCR-3	50018	8	0.750	0.590	1.305	6.00	3.00	9.00	DBOMH-12/20M-STUCR3	TCMT-32.52	TS-4.7-10M1	T-15
73310159342	STI12X-10-QCBB-11-SB-STUCR-3	50019	10	0.750	0.590	1.305	7.50	3.00	10.50				
73310159360	STI12X-12-QCBB-13--STUCR-3	50020	12	0.750	0.590	1.305	9.00	3.00	12.00				
73310159340	STI16X-08-QCBB-12-SB-STUCR-3	50021	8	1.000	0.715	1.555	8.00	4.00	12.00	DBOMH-12/20M-STUCR3	TCMT-32.52	TS-4.7-10M1	T-15
73310159429	STI16X-10-QCBB-14-SB-STUCR-3	50022	10	1.000	0.715	1.555	10.00	4.00	14.00				
73310159361	STI16X-12-QCBB-16-SB-STUCR-3	50023	12	1.000	0.715	1.555	12.00	4.00	16.00				
73310159341	STI20X-08-QCBB-15-SB-STUCR-3	50024	8	1.250	0.840	1.805	10.00	5.00	15.00	DBOMH-12/20M-STUCR3	TCMT-32.52	TS-4.7-10M1	T-15
73310159471	STI20X-10-QCBB-18-SB-STUCR-3	50025	10	1.250	0.840	1.805	12.50	5.00	17.50				
73310159362	STI20X-12-QCBB-20-SB-STUCR-3	50026	12	1.250	0.840	1.805	15.00	5.00	20.00				

UPC No.	Solution Tool! Boring Bar Part Number	UPC No.	Boring Ratio	D	F1	MB	Lenght of Cut	C2	C	Boring Head Part No.	Inserg Gage	Insert Torx Screw	Insert Torx Key
SolutionTool!™	Solution Tool! Steel Boring Bar™			SCLCR-3 Boring			CCMT-32.52 Insert			Inch Size			
73310159428	STI12X-08-QCBB-9-SB-STUCR-3	50027	8	0.750	0.625	1.375	6.00	3.00	9.00	DBOMH-12/20M-SVUCR-2	VCMT-221	TS-25.45.6M2	T-8
73310159342	STI12X-10-QCBB-11-SB-STUCR-3	50028	10	0.750	0.625	1.375	7.50	3.00	10.50				
73310159360	STI12X-12-QCBB-13--STUCR-3	50029	12	0.750	0.625	1.375	9.00	3.00	12.00				
73310159340	STI16X-08-QCBB-12-SB-STUCR-3	50030	8	1.000	0.750	1.625	8.00	4.00	12.00	DBOMH-12/20M-SVUCR-3	VCMT-332	TS-4.7-10M1	T-15
73310159429	STI16X-10-QCBB-14-SB-STUCR-3	50031	10	1.000	0.750	1.625	10.00	4.00	14.00				
73310159361	STI16X-12-QCBB-16-SB-STUCR-3	50032	12	1.000	0.750	1.625	12.00	4.00	16.00				
73310159341	STI20X-08-QCBB-15-SB-STUCR-3	50033	8	1.250	0.875	1.875	10.00	5.00	15.00	DBOMH-12/20M-SVUCR-3	VCMT-332	TS-4.7-10M1	T-15
73310159471	STI20X-10-QCBB-18-SB-STUCR-3	50034	10	1.250	0.875	1.875	12.50	5.00	17.50				
73310159362	STI20X-12-QCBB-20-SB-STUCR-3	50035	12	1.250	0.875	1.875	15.00	5.00	20.00				

Solution Tool!™ The NO! Vibration Tunable Boring Bar

Solution Tool!™ The NO! Vibration Tunable Boring Bar

ADCLN R/L Solution Tool!™ Thru Coolant Jet-Stream™ Modular Boring Head Style L - Negative 5° End & Side Cutting Edge Angle for negative 80° diamond CN__ inserts

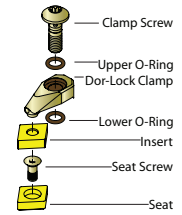
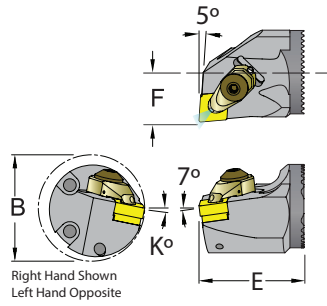
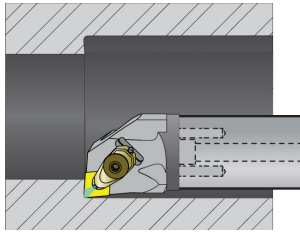

Thru Coolant

Head Description	UPC No. 733101-		B		E		F		K°	Bars Dia.		CNMG Gage Insert		Seat	Seat Screw	Dor-Lock Clamp	Clamp Screw
	R.H.	L.H.	Inch	Metric	Inch	Metric	Inch	Metric		Inch	Metric	Inch	Metric				
DBOMH-24/40M-ADCLNR/L-4	59507	59508	1.780	45.21	1.575	40	1.125	25.580	11°	1.5"/4.0"	40/100	432	120408	DC-432	TS-5.8-10M1	JSLC-HPCTW-4N	JSCS-04
DBOMH-24/40M-ADCLNR/L-5	59509	59510	1.780	45.21	1.575	40	1.125	25.580	11°	1.5"/4.0"	40/100	543	160612	DC-533	TS-5.8-10M1	JSLC-HPC-5	JSCS-04

ADDQN R/L Solution Tool!™ Thru Coolant Jet-Stream™ Modular Boring Head Style Q-Negative 17. 5° End Cutting Edge Angle for 7° positive 55° diamond DN__ inserts

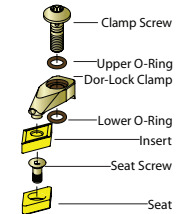
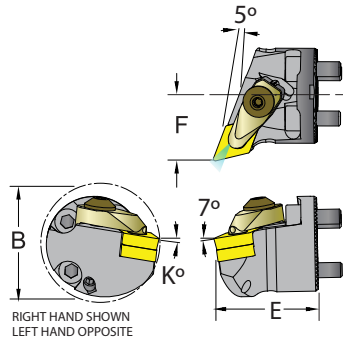
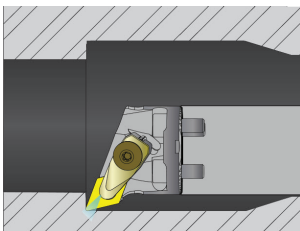

Thru Coolant

Head Description	UPC No. 733101-		B		E		F		K°	Bars Dia.		DNMG Gage Insert		Seat	Seat Screw	Dor-Lock Clamp	Clamp Screw
	R.H.	L.H.	Inch	Metric	Inch	Metric	Inch	Metric		Inch	Metric	Inch	Metric				
DBOMH-24/40M-ADDQNR/L-4	59476	59477	1.88	47.752	1.625	41.275	1.032	26.2128	11°	1.5"/4.0"	40/100	432	150408	DD-432	TS-5.8-10M1	JSLC-HPD4	JSCS-04
DBOMH-24/40M-ADDQNR/L-15	59478	59479	1.88	47.752	1.625	41.275	1.032	26.2128	11°	1.5"/4.0"	40/100	442	150608	DD-422	TS-5.8-10M2	JSLC-HPD4	JSCS-04

Solution Tool!™ The NO! Vibration Tunable Boring Bar

ADDUN R/L Solution Tool!™ Thru Coolant Jet-Stream™ Modular Boring Head Style U - Negative 3° End Cutting Edge Angle for negative 55° diamond DN__ inserts

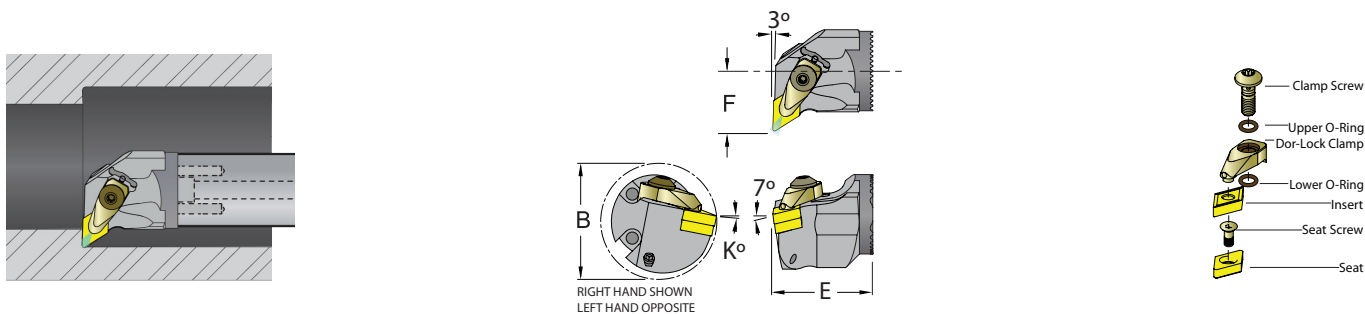

Thru Coolant

Head Description	UPC No. 733101-		B		E		F		K°	Bars Dia.		DNMG Gage Insert		Seat	Seat Screw	Dor-Lock Clamp	Clamp Screw
	R.H.	L.H.	Inch	Metric	Inch	Metric	Inch	Metric		Inch	Metric	Inch	Metric				
	DBOMH-24/40M-ADDUNR/L-4	59387	59388	2.25	57.15	1.575	40.005	1.125		28.58	11	1.5	40				
DBOMH-24/40M-ADDUNR/L-15	59511	59512	2.25	57.15	1.575	40.005	1.125	28.58	11	1.5	40	442	150608	DD-422	TS-5.8-10M2	JSLC-HPD4	JSCS-04

ADTUN R/L Solution Tool!™ Thru Coolant Jet-Stream™ Modular Boring Head Style U - Negative 3° End & Side Cutting Edge Angle for negative 60° triangle TN__ inserts

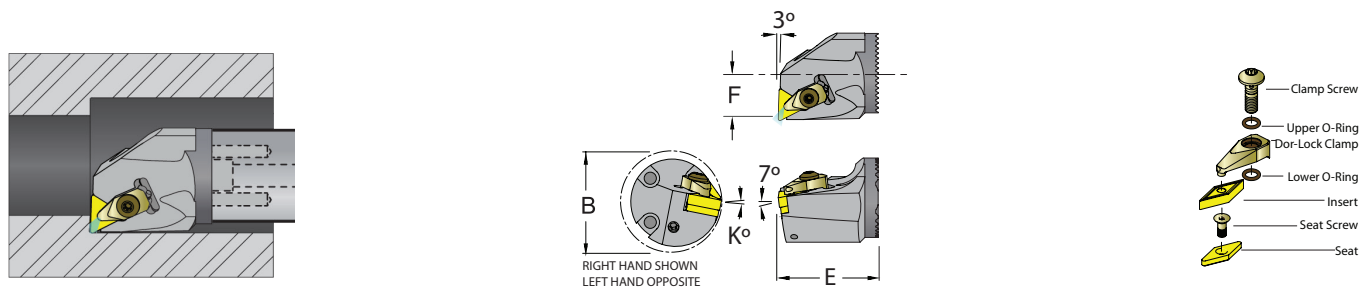

Thru Coolant

Head Description	UPC No. 733101-		B		E		F		K°	Bars Dia.		TNMG Gage Insert		Seat	Seat Screw	Dor-Lock Clamp	Clamp Screw
	R.H.	L.H.	Inch	Metric	Inch	Metric	Inch	Metric		Inch	Metric	Inch	Metric				
	DBOMH-24/40M-ADTUNR/L-3	59515	59516	2.060	52.32	1.575	40	1.125		25.580	11°	1.5"/4.0"	40/100				
DBOMH-24/40M-ADTUNR/L-4	59517	59518	2.060	52.32	1.575	40	1.125	25.580	11°	1.5"/4.0"	40/100	432	220408	DT-432	TS-5.8-10M1	JSLC-HPTW-4R/L	JSCS-04

Solution Tool!™ The NO! Vibration Tunable Boring Bar

ADVUN R/L Solution Tool!™ Thru Coolant Jet-Stream™ Modular Boring Head Style U - Negative 3° End Cutting Edge Angle for negative 35° diamond VN__ inserts

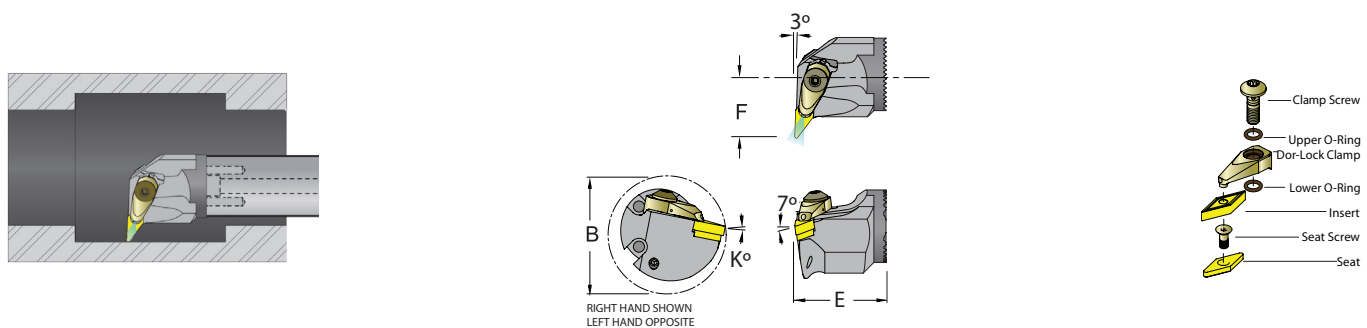

Thru Coolant

Head Description	UPC No. 733101-		B		E		F		K°	Bars Dia.		VNMG Gage Insert		Seat	Seat Screw	Dor-Lock Clamp	Clamp Screw
	R.H.	L.H.	Inch	Metric	Inch	Metric	Inch	Metric		Inch	Metric	Inch	Metric				
	DBOMH-24/40M-ADVUNR/L-3	59521	59522	2.500	63.50	1.575	40	1.125		25.580	11°	1.5"/4.0"	40/100				

ADWLN R/L Solution Tool!™ Thru Coolant Jet-Stream™ Modular Boring Head Style L - Negative 5° End & Side Cutting Edge Angle for negative 80° trigon WN__ inserts

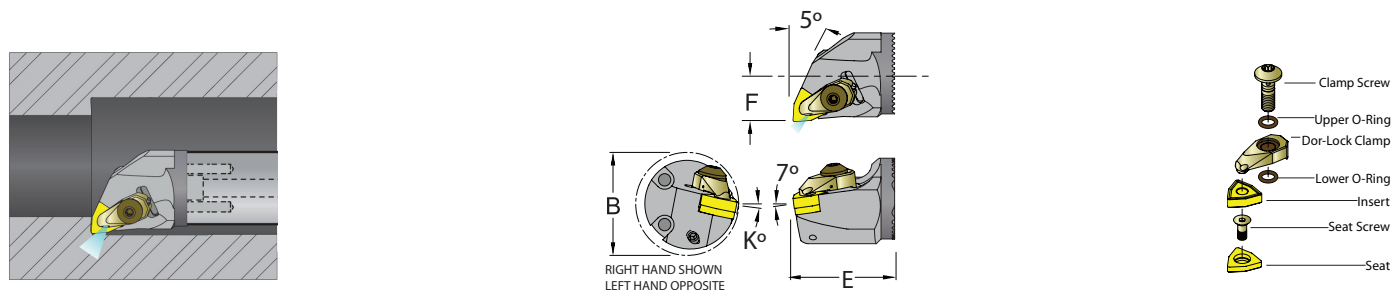

Thru Coolant

Head Description	UPC No. 733101-		B		E		F		K°	Bars Dia.		WNMG Gage Insert		Seat	Seat Screw	Dor-Lock Clamp	Clamp Screw
	R.H.	L.H.	Inch	Metric	Inch	Metric	Inch	Metric		Inch	Metric	Inch	Metric				
	DBOMH-24/40M-ADWLNRL-4	59525	59526	1.900	48.26	1.575	40	1.125		25.580	11°	1.5"/4.0"	40/100				

Solution Tool!™ The NO! Vibration Tunable Boring Bar

ASCLC R/L Solution Tool!™ Thru Coolant Jet-Stream™ Modular Boring Head Style L - Negative 5° End & Side Cutting Edge Angle for 7° positive 80° diamond CC__ inserts

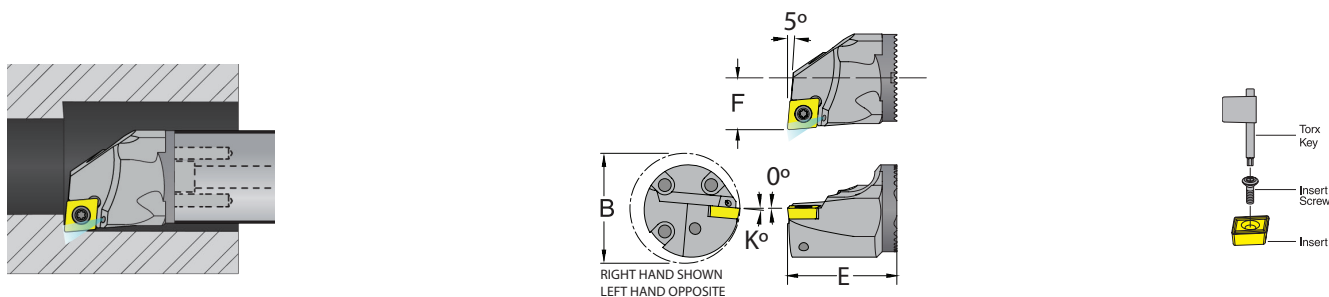

Thru Coolant

Head Description	UPC No. 733101-		B		E		F		K°	Bars Dia.		CCGW Gage Insert		Insert Screw	Torx Key
	R.H.	L.H.	Inch	Metric	Inch	Metric	Inch	Metric		Inch	Metric	Inch	Metric		
DBOMH-24/40M-ASCLNR/L-4	59529	59530	1.780	45.21	1.575	40	1.125	25.580	5°	1.5"/4.0"	40/100	432	120408	TS-5.8-10M1	T-20

ASDQC R/L Solution Tool!™ Thru Coolant Jet-Stream™ Modular Boring Head Style Q - Negative 17.5° End & Side Cutting Edge Angle for 7° positive 55° diamond DC__ inserts

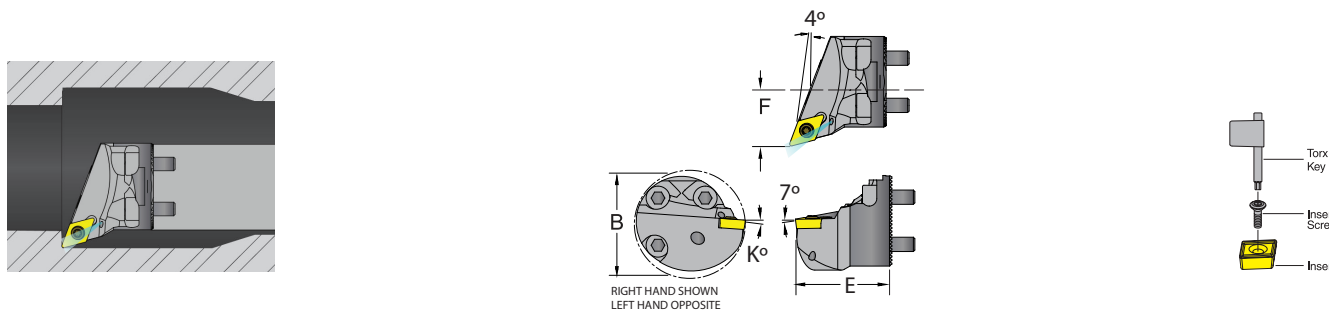

Thru Coolant

Head Description	UPC No. 733101-		B		E		F		K°	Bars Dia.		DCMT Gage Insert		Insert Screw	Torx Key
	R.H.	L.H.	Inch	Metric	Inch	Metric	Inch	Metric		Inch	Metric	Inch	Metric		
DBOMH-24/40M-ASDQNR/L-3	59474	59475	2.125	53.975	1.595	40.513	1.06	26.924	4°	1.5"/4.0"	40/100	32.52	11T308	TS-4.7-8M1	T-15
DBOMH-24/40M-ADSQNR/L-4	59389	59390	2.125	53.975	1.595	40.513	1.06	26.924	4°	1.5"/4.0"	40/100	432	150408	TS-5.8-10M1	T-20

Solution Tool!™ The NO! Vibration Tunable Boring Bar

ASDUC R/L Solution Tool!™ Thru Coolant Jet-Stream™ Modular Boring Head Style U - Negative 3° End Cutting Edge Angle for 7° positive 55° diamond DC__ inserts

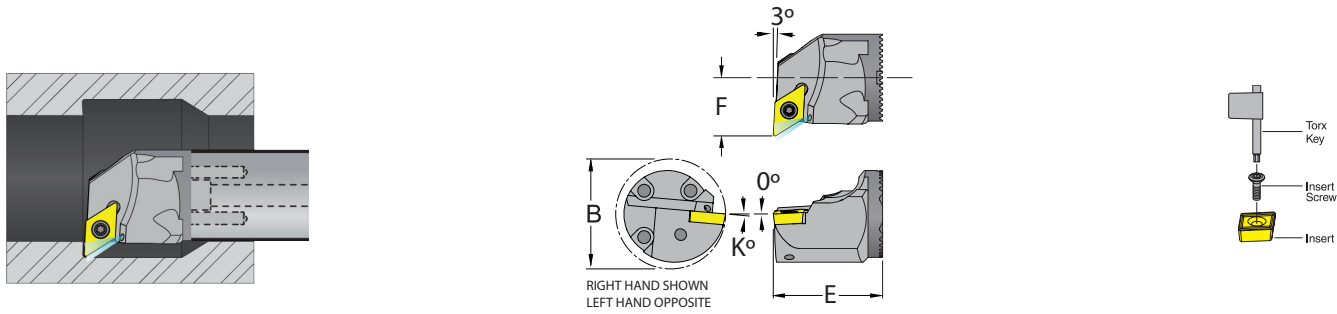

Thru Coolant

Head Description	UPC No. 733101-		B		E		F		K°	Bars Dia.		DCGW Gage Insert		Insert Screw	Torx Key
	R.H.	L.H.	Inch	Metric	Inch	Metric	Inch	Metric		Inch	Metric	Inch	Metric		
	DBOMH-24/40M-ASDUCR/L-3	59533	59534	2.250	57.15	1.575	40	1.125		25.580	4°	1.5"/4.0"	40/100		
DBOMH-24/40M-ASDUCR/L-4	59535	59536	2.250	57.15	1.575	40	1.125	25.580	4°	1.5"/4.0"	40/100	432	150408	TS-5.8-10M1	T-20

ASTUC R/L Solution Tool!™ Thru Coolant Jet-Stream™ Modular Boring Head Style U - Negative 3° End Cutting Edge Angle for 7° positive triangle TC__ inserts

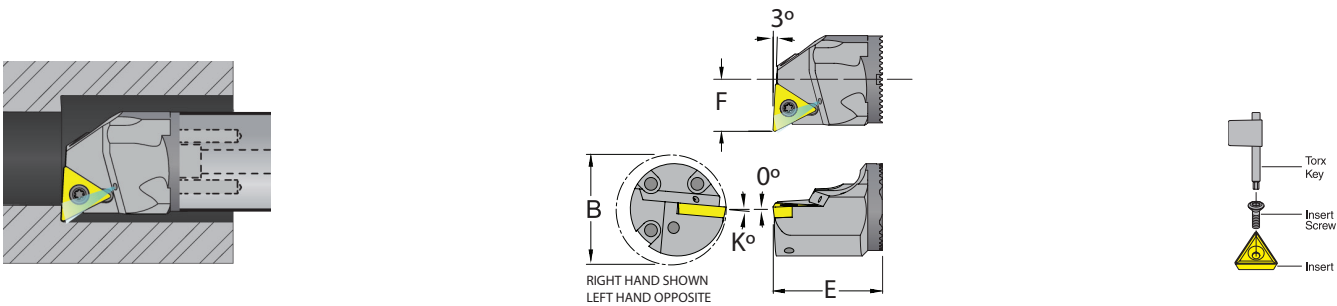

Thru Coolant

Head Description	UPC No. 733101-		B		E		F		K°	Bars Dia.		TCGW Gage Insert		Insert Screw	Torx Key
	R.H.	L.H.	Inch	Metric	Inch	Metric	Inch	Metric		Inch	Metric	Inch	Metric		
	DBOMH-24/40M-ASTUCR/L-3	59539	59540	1.780	57.15	1.575	40	1.125		25.580	5°	1.5"/4.0"	40/100		
DBOMH-24/40M-ASTUCR/L-4	59541	59542	1.780	57.15	1.575	40	1.125	25.580	5°	1.5"/4.0"	40/100	432	220408	TS-5.8-10M1	T-20

Solution Tool!™ The NO! Vibration Tunable Boring Bar

ASVUC R/L Solution Tool!™ Thru Coolant Jet-Stream™ Modular Boring Head Style U - Negative 3° End Cutting Edge Angle for 7° positive 35° diamond VC__ inserts

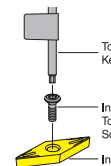
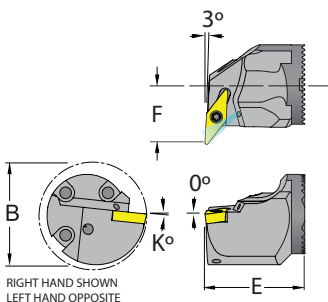
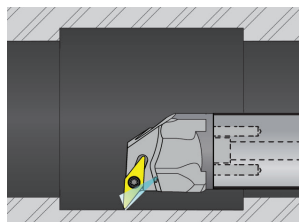

Thru Coolant

Head Description	UPC No. 733101-		B		E		F		K°	Bars Dia.		VCGW Gage Insert		Insert Screw	Torx Key
	R.H.	L.H.	Inch	Metric	Inch	Metric	Inch	Metric		Inch	Metric	Inch	Metric		
	DBOMH-24/40M-ASVUCR/L-3	59545	59546	2.500	63.50	1.575	40	1.125		25.580	6°	1.5"/4.0"	40/100		

ADLN R/L Solution Tool!™ Thru Coolant Jet-Stream™ Threading Modular Head Style N for laydown 16-G60 & 22-N60 inserts

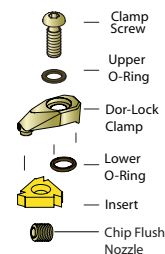
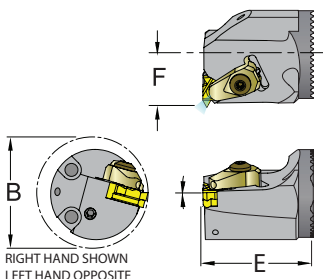
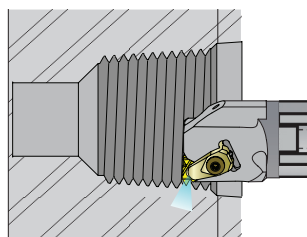

Thru Coolant

Head Description	UPC No. 733101-		B		E		F		Bars Dia.		Laydown Gage Insert	Seat	Seat Screw	Dor-Lock Clamp	Clamp Screw	Chip Flush Nozzle
	R.H.	L.H.	Inch	Metric	Inch	Metric	Inch	Metric	Inch	Metric						
DBOMH-24/40M-ADLNR/L-16	59549	59550	1.870	47.50	1.575	40	1.125	25.580	1.5"/4.0"	40/100	16-G60	GXE-I16	TS-35.6-14M1	JSLC-HP16L-N JSLC-HP16R-N	JSCS-03	JSPN-M6
DBOMH-24/40M-ADLNR/L-22	59553	59554	2.000	50.80	1.575	40	1.125	25.580	1.5"/32"	32/100	22-N60	NXE-I22	TS-45.75-15M1	JSLC-HP22N	JSCS-04	JSPN-M6

*For right hand tool. **For left hand tool.

Solution Tool!™ The NO! Vibration Tunable Boring Bar

ADNE R/L Solution Tool!™ Thru Coolant Jet-Stream™ Threading Modular Head Style E - for DorNotch NG__3 inserts

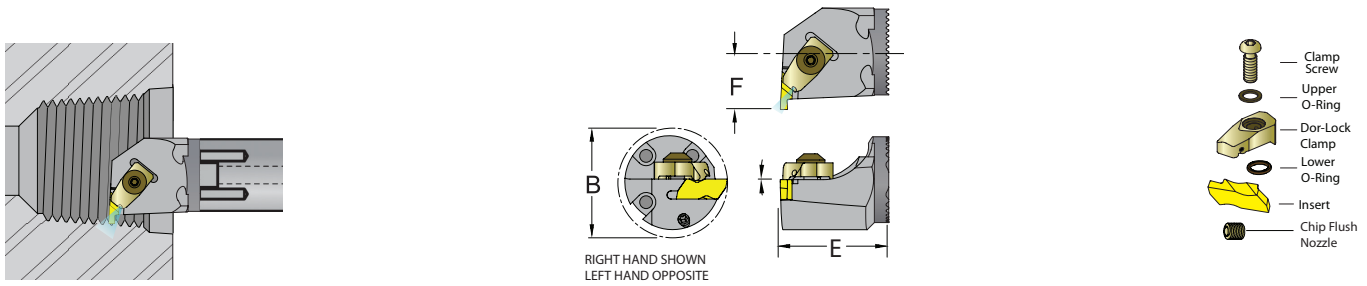

Thru Coolant

Head Description	UPC No. 733101-		B		E		F		Bars Dia.		DorNotch Gage Insert	Dor-Lock Clamp	Clamp Screw	Chip Flush Nozzle
	R.H.	L.H.	Inch	Metric	Inch	Metric	Inch	Metric	Inch	Metric				
DBOMH-24/40M-ADNER/L-3	59557	59558	2.000	50.80	1.575	40	1.125	25.580	1.57/4.0"	40/100	NG-3L* NG-3R**	JSLC-HP73* JSLC-HP72**	JSCS-08	JSPN-M6

*For right hand tool. **For left hand tool.

ADTHO R/L Solution Tool!™ Thru Coolant Jet-Stream™ Threading Modular Head Style Head for triangle TNMC 432__inserts

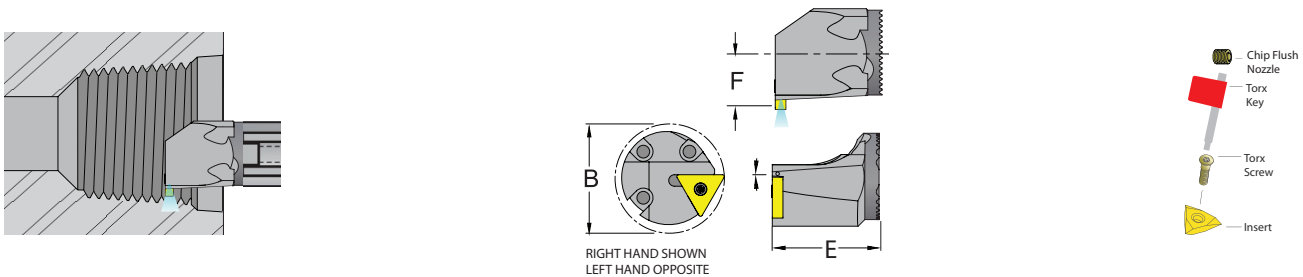

Thru Coolant

Head Description	UPC No. 733101-		B		E		F		Bars Dia.		TNMC Gage Insert		Insert Seat Screw	Tork Key	Chip Flush Nozzle
	R.H.	L.H.	Inch	Metric	Inch	Metric	Inch	Metric	Inch	Metric	Inch	Metric			
DBOMH-24/40M-ADTHOR/L-4	59561	59562	2.250	57.15	1.575	40	1.125	25.580	1.57/4.0"	40/100	432	220408	GTS-2	T-20	JSPN-M6

Note: For machines that have turrets with 1/8 NTP tapped coolant holes, you do not need a ball type coolant nozzle . Ball type coolant nozzles are sold separately.

Solution Tool!™ The NO! Vibration Tunable Boring Bar

Boring Bars and Tolholders-Low Pressure Coolant Connection 3 Pcs. Kit

Working Pressure

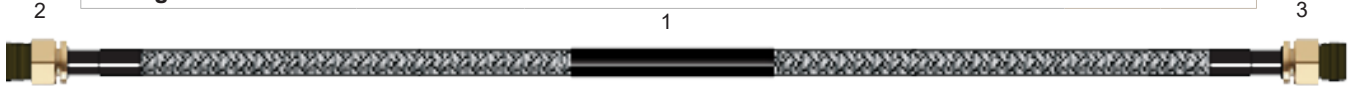

up to 400 psi (30 bar)

Item	Part Number	UPC No 733101-	Description	Bar	PSI
1/8" NPT Low Pressure Quick Release Coolant 3 pcs Kit					
1	JS-T250-1200	53349	1/4" OD, 12" Low High Pressure Long Tubing	30	400
2	JS-MC062-250	53346	1/16" NPT-1/4" Bore, Straight Low Pressure Quick Release Connector		
3	JS-MC125-250	53347	1/8" NPT-1/4" Bore, Straight Low Pressure Quick Release Connector		
1/8" NPT Low Pressure Quick Release Coolant 3 pcs Kit					
1	JS-T250-1200	53349	1/4" OD, 12" Low High Pressure Long Tubing	30	400
2	JS-MC125-250	53347	1/8" NPT-1/4" Bore, Straight Low Pressure Quick Release Connector		
3	JS-MC125-250	53347	1/8" NPT-1/4" Bore, Straight Low Pressure Quick Release Connector		
1/4" NPT Low Pressure Quick Release Coolant 3 pcs Kit					
1	JS-T250-1200	53349	1/4" OD, 12" Low High Pressure Long Tubing	30	400
2	JS-MC125-250	53347	1/8" NPT-1/4" Bore, Straight Low Pressure Quick Release Connector		
3	JS-MC250-250	53348	1/4" NPT-1/4" Bore, Straight Low Pressure Quick Release Connector		

Boring Bars and Tolholders-High Pressure Coolant Connection 5 Pcs. Kit

Working Pressure



over 400 psi (30 bar)

Item	Part Number	UPC No 733101-	Description	Bar	PSI
1/8" NPT High Pressure Quick Release Coolant 5 pcs Kit					
1	DT-HPTU-8X4	60477	8mm High Pressure 8mm Coolant Tubing Only	200	2800
2	DT-HP90C-1/8x6	60479	High Pressure Quick Release Straight Intec		
3	DT-HP90C-1/8x6	60479	High Pressure Quick Release Straight Intec		
4	DT-HP90C-1/8x6	60490	1/8" NPT Straight High Pressure Quick Release Connector		
5	DT-HP90C-1/8x6	60489	1/8" NPT 90° Elbow High Pressure Quick Release Connector		
1/4" NPT High Pressure Quick Release Coolant 5 pcs Kit					
1	DT-HPTU-8X4	60477	8mm High Pressure 8mm Coolant Tubing Only	200	2800
2	DT-HP90C-1/8x6	60479	High Pressure Quick Release Straight Intec		
3	DT-HP90C-1/8x6	60479	High Pressure Quick Release Straight Intec		
4	DT-HPOSC-1/4x6	60478	1/4" NPT Straight High Pressure Quick Release Connector		
5	DT-HP90C-1/8x6	60489	1/8" NPT 90° Elbow High Pressure Quick Release Connector		

Item	Part Number	UPC No 733101-	Description
	TD-HP-WRENCH	60076	High Pressure Disconnecting Wrench

To Disconnect the Hydraulic Coolant Hose Follow 2 Safe & Easy Steps:

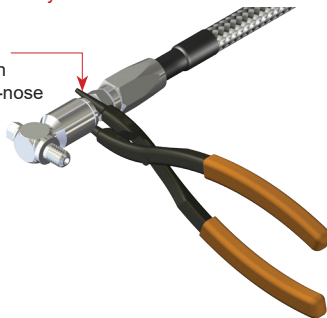

1. Place the thinner section of the wrench-nose between the coolant hose and the connector.

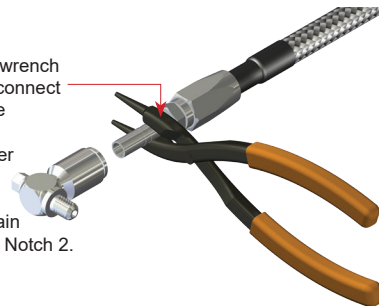

2. Close the wrench and it will disconnect Notch 1 of the coolant hose. Use the thicker section of the wrench-nose and close again to disconnect Notch 2.



Ball-Type Coolant Nozzles Sold Separately

Acetal Material	Brass Material	Ball-Type Coolant Nozzles Size	Acetal Material		Brass Material	
			Desc.	UPC NO. 733101-	Desc.	UPC NO. 733101-
		12mm OD, 1/8NPT ID	JSCNA-12	53354	JSCNB-12	53365
		14mm OD, 1/8NPT ID	JSCNA-14	53355	JSCNB-14	53366
		15mm OD, 1/8NPT ID	JSCNA-15	53356	JSCNB-15	53367
		22mm OD, 1/8NPT ID	JSCNA-22	53357	JSCNB-22	53368
		1/2" OD, 1/8NPT ID	JSCNA-50	53358	JSCNB-50	53369
		5/8" OD, 1/8NPT ID	JSCNA-62	53359	JSCNB-62	53370

Note: For machines that have turrets with 1/8 NPT tapped coolant holes, you do not need a ball type coolant nozzle. Ball type coolant nozzles are sold separately.