

Threading, Grooving & API



Threading , Grooving & API System

Threading and Grooving Recommendation Form	Page E-3
Threading and Grooving System	Page E-4
Threading & Grooving Technical Data	Page-D-5 - E-11
Threading & Grooving Insert Grades	Page E-12
Threading & Grooving Insert Index	Page E-13

On Edge Threading and Grooving Inserts , Toolholders & Bars

On Edge Threading and Grooving Inserts	Page E-14 - E-17
On Edge Threading and Grooving Toolholders	Page E-27 - E-32

Laydown Threading Inserts , Toolholders & Bars

Laydown Threading Inserts	Page E-18 - E-22
Laydown Threading and Grooving Toolholders	Page E-33 - E-37

DorNotch Threading Inserts , Toolholders & Bars

DorNotch Threading and Grooving Inserts	Page E-23 - E-25
DorNotch Threading and Grooving Toolholders	Page E-38 - E-40

API Threading Inserts , Toolholders & Bars

API On Edge Threading and Grooving Toolholders	Page E-41
API On Edge Jet-stream™ Thru Coolant Threading and Grooving Toolholder	Page E-41
API On Edge Jet-stream™ Thru Coolant Threading and Grooving Bar	Page E-41
API Laydown Threading Toolholders	Page E-42
API DorNotch Threading and Grooving Toolholders	Page E-43
API DorNotch Jet-stream™ Thru Coolant Threading Toolholders	Page E-43
API DorNotch Jet-stream™ Thru Coolant Threading Bar	Page E-43
L-API Threading Toolholders	Page E-44
API Chaser Threading Toolholders	Page E-45

Threading & Grooving Spare Parts

Threading & Grooving Spare Parts	Page E-46
----------------------------------	-----------

Threading and Grooving Recommendation Form

When selecting an indexable threading tool & Insert you must check the appropriate box for each area below and fax to 979-282-2951.

1. Operations

O.D. Threading O.D. Grooving I.D. Threading I.D. Grooving O.D. API I.D. API

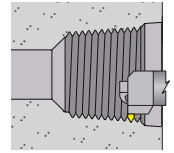
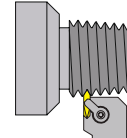
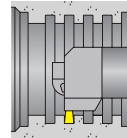
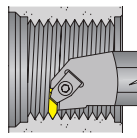
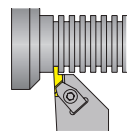
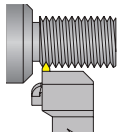

2. Thread Size

inch mm inch mm inch mm inch mm inch mm inch mm

3. Material

Carbon Steel Hardened Steel PH Series Stainless Steel 300 Series Stainless Steel Aluminum Non-Ferrous
 Alloy Steel Martensitic Stainless Steel 400 Series Stainless Steel Cast Iron High Temper Alloy

4. Tool Shank

OnEdge Laydown DorNotch V Bottom L-API API Chaser

5. Tool Size

Square Shank Size: _____ Threading Bar Size: _____

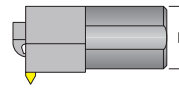
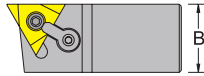

6. Cutting Direction

Square Shank

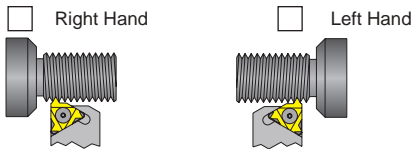

Threading Bar

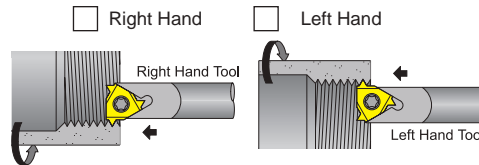

7. Machine Type

Manual Swiss CNC Other

8. Insert Geometry

On Edge Laydown DorNotch



9. Insert Size I.C.

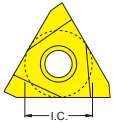

3/8" I.C. 6mm No. 2
 1/2" I.C. 8mm No. 3
 5/8" I.C. 11mm No. 4
 16mm 22mm
 27mm

10. (a) Insert TPI

Inch Diameter _____ Length _____ TPI _____

10. (b) Insert Pitch

Metric Diameter _____ Length _____ Metric Pitch _____

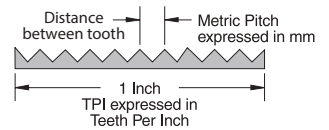

Quote No. _____ P.O. No. _____

Recommended By :	To be Completed by Dorian Tool Engineering Department	Company Name:
	UPC No. 733101- Inch Description Delivery	Contact Name:
Square Shank		Phone No: ()
Threading Bar		Fax No: ()
Insert		Address

On Edge

"THE ECONOMY SYSTEM"

3 Cutting Edge

External



Internal

The most popular threading and grooving system in the industry. The toolholders and boring bars are to be used with threading or grooving inserts, for either external or internal applications, in right or left hand cutting direction.

- Two (2) types of locking systems available:
- "M" - Multi lock system for TNMA style insert
- "S" - Torx screw locking system for TNMC style insert

On edge 60° triangle threading inserts have three (3) cutting edges. The insert is mounted on the side or end of the threading holder or boring bar. The same insert can be used for either OD or ID threading, in right hand or left hand cutting direction.

- "A" style with straight hole for "M" style holder and boring bar
- "C" style with double countersink for "S" style holder and boring bar

The on edge system offers a complete selection of thread, API, and groove form inserts.

Laydown Threading

"THE CLEARANCE SYSTEM"

3 Cutting Edge

External



Internal

The most compact system designed for external or internal threading applications, for right and left hand cutting direction. The great advantage of this system over others, is the ability to thread the smallest bore diameters allowed in single point threading operation.

The three (3) cutting edge insert is locked down in horizontal position over the holder or boring bar, allowing the chip to flow without restriction.

The laydown threading system offers the most complete selection of thread-form insert line in inches (TPI), metric (ISO), and API with single and multi thread form, in full or partial thread profile.

DorNotch Threading

"THE RIGIDITY SYSTEM"

2 Cutting Edge

External



Internal

The unique clamping design of DorNotch, makes it the most rigid threading system. The insert nested on the side of the holder or the end of the boring bar is held extremely secure with a top clamp, forcing the insert down and against the walls of the pocket. This assures the best tool life, a chatter free surface finish, and a precise workpiece quality.

DorNotch threading and grooving holders and boring bars are built with precise quality. They are available in many sizes, making the DorNotch holders and boring bars the perfect choice for heavy duty threading applications, for either OD or ID applications, in right hand or left hand cutting direction.

The DorNotch threading and grooving system offers a large selection of thread, API, and groove form inserts.

Machining Applications		Machining Applications		Machining Applications	
Best	Good	Best	Not Available	Best	Best
External Threading	Grooving	Internal Threading	Grooving	Threading	Int. & Ext. Grooving
			NA		

Insert Cutting Edge				Insert Cutting Edge		Insert Cutting Edge			
Threading		Grooving		Threading		Threading		Grooving	
Positive Rake	Negative Rake	Positive Rake	Negative Rake	Positive Rake		Positive Rake	Negative Rake	Positive Rake	Negative Rake

Threading, Grooving & API Methods

O.D Threading

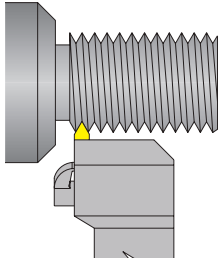

I.D. Threading

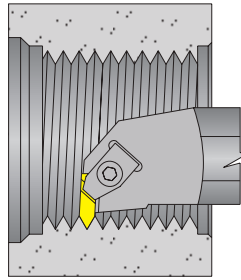

Grooving

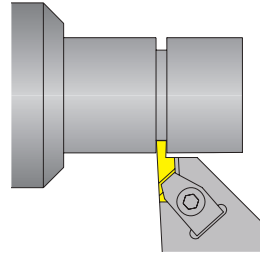

API

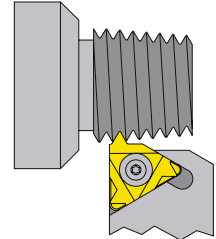

Thread Terminology

ANSI

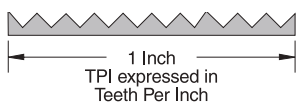

ISO

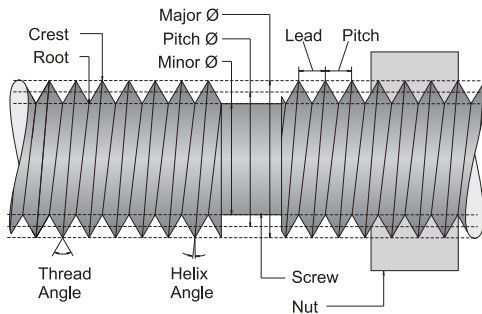
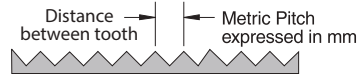

Single Lead Thread

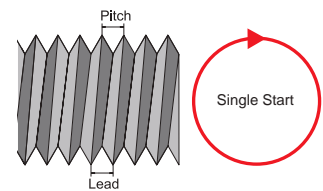

Double Lead Thread

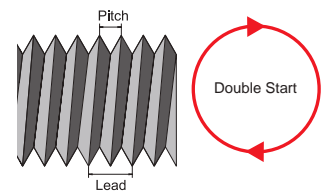

Thread Definitions

Crest - The outer most surface of the thread form which joins the flanks.

Helix angle - The angle between the direction of the threads around a screw and a line running at a right angle to the shank.

Lead - The distance a thread will advance along its axis in one complete revolution.
major diameter - The largest diameter of a straight screw thread.

Minor diameter - The smallest diameter of a screw thread. Also known as the "root diameter."

Pitch - The distance from any point on a thread to the corresponding point on the adjacent thread measured parallel to the axis.

Pitch diameter - The diameter of a thread at an imaginary point where the width of the groove and the width of the thread are equal.

Root - The inner most surface of a thread form.

Thread angle - The angle formed by the two sides of the thread (or their projections) with each other.

Right Hand Thread

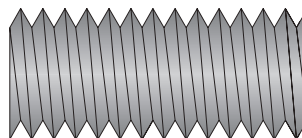

Left Hand Thread

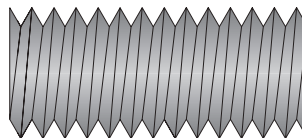

Triple Lead Thread

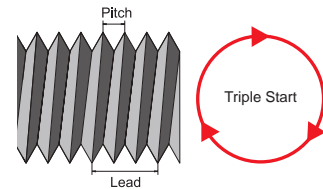

Industry Standard Threads

Thread Type	ISO Metric	American UN	Whitworth	American NPT
Profiles				
Thread Use	General Purpose		Pipe fittings for gas, water and sewer	

Thread Type	Round	Round	BSPT	American NPTF
Profiles				
Thread Use	Pipe fittings for food service applications		Pipe fittings for steam, gas and water	

Thread Type	American Buttress	Metric Buttress	UNJ
Profiles			
Thread Use	Pipe fittings for steam, gas and water		Aerospace applications

Thread Type	30° Trapez ACME	ACME	Stub ACME
Profiles			
Thread Use	Motion transmissions		

Thread Type	API Round	Buttress	Rotary Shoulder
Profiles			
Thread Type	X-Line	Hughes H90	
Profiles			
Thread Use	Oil and gas		

Thread Cutting Methods

In-feed Angle & Cutting Directions (→) Shown below

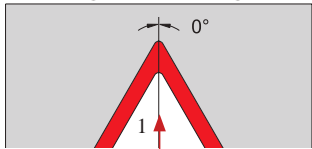
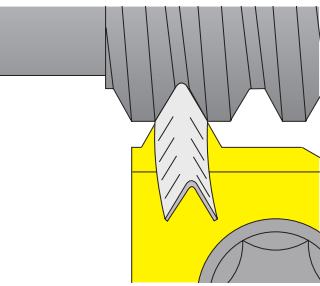
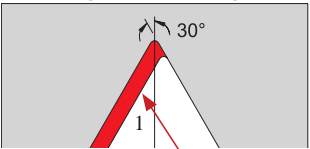
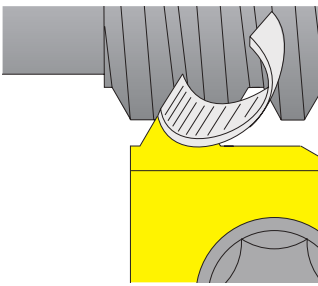
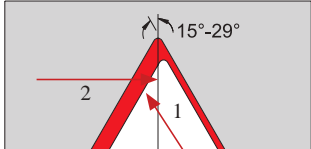
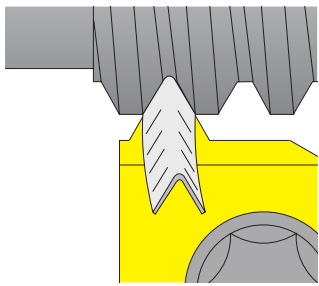
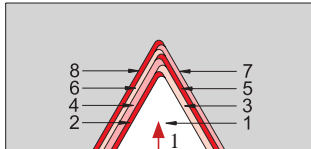
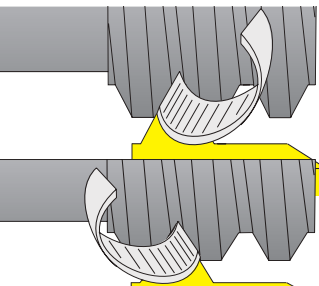
<p>Single Infeed Angle</p>  <p>Radial Infeed (Cut both sides simultaneously)</p>  <p>Pros:</p> <ul style="list-style-type: none"> • Most commonly used • Often only choice in mechanical operations • Edge is protected from chipping since all of the cutting edge is located in the cut <p>Cons:</p> <ul style="list-style-type: none"> • Channel chip is created that may be difficult to control • Burr condition is increased • Tends to chatter 	<p>Single Infeed Angle</p>  <p>Flank Infeed (Cut one side only)</p>  <p>Pros:</p> <ul style="list-style-type: none"> • Leading edge of insert is used to make the cut resulting in better chip flow • Reduced Burring <p>Cons:</p> <ul style="list-style-type: none"> • Trail edge of insert is prone to chipping • Poor choice of soft materials like aluminum, stainless steel or low carbon steel 	<p>Infeed & Crossfeed Angle</p>  <p>Modified Flank (Cut one side only & finish opposite)</p>  <p>Pros:</p> <ul style="list-style-type: none"> • Edge is protected from chipping since all of the cutting edge is located in the cut <p>Cons:</p> <ul style="list-style-type: none"> • Channel chip is created that may be difficult to control • Burr condition is increased • Tends to chatter 	<p>Infeed & Double Crossfeed Angle</p>  <p>Alternating Flank (Multicut)</p>  <p>Pros:</p> <ul style="list-style-type: none"> • Mainly used for large profiles • Increased Tool Life • Insert wears evenly <p>Cons:</p> <ul style="list-style-type: none"> • Difficult to achieve manually • Requires special programs on CNC machines
---	--	---	--

Infeed Values for Threading

Threading Formulas			
a_p = Depth of cut (doc)	Inch/mm	P = Pass number	Inch/mm
a_1 = Infeed 1	Inch/mm	$I_{\#}$ = Infeed per pass	Inch/mm
$a_{\#}$ = Accumulated depth per pass	Inch/mm	Note: # = Infeed pass number 2, 3, 4, etc	
Infeed for Pass 1 25% of Total	$a_1 = \frac{a_p}{4}$	Example: Determine the first pass infeed(a_1) for a thread with a total depth(a_p) of 0.132 inches.	$a_1 = \frac{0.132}{4} = 0.033$ in
Accumulated Infeed for Additional Passes	$a_{\#} = a_1 \times \sqrt{P}$	Example: Determine the accumulated infeed($a_{\#}$) for the fourth pass(P) on a thread with a total depth(a_p) of 0.132 inches and a first pass infeed(a_1) of 0.033 inches.	$a_4 = 0.033 \times \sqrt{4} = 0.066$ in
Infeed per Individual Pass	$I_p = a_{\#} - a_{\#-1}$	Example: Determine the infeed for third pass of a threading operation with an accumulated infeed for the third pass($a_{\#}$) of 0.0572 and an accumulated infeed of 0.0467 for the second pass($a_{\#-1}$).	$I_p = 0.0572 - 0.0467 = 0.0105$
Multi-Tooth Applications	<ul style="list-style-type: none"> • As a rule of thumb, divide the total number of infeed passes required for a single tooth insert by the number of teeth on a multi-tooth insert to find total infeed passes needed. • Find accumulated infeed depths for multiples of the tooth number (For 3 teeth find a_p for passes 1, 3, 6, 9, etc) 		

Recommended Infeed Values for External UN Threads - Steel

No. Of Passes	TPI																				
	4	5	6	7	8	9	10	11	12	13	14	16	18	20	24	28	32	36	40	44	48
1	.0353	.0298	.0248	.0213	.0197	.0175	.0169	.0157	.0152	.0142	.0136	.0125	.0124	.0119	.0118	.0112	.0098	.0087	.0078	.0073	.0065
2	.0146	.0122	.0105	.0088	.0082	.0073	.0070	.0066	.0064	.0057	.0059	.0054	.0053	.0049	.0048	.0046	.0042	.0036	.0032	.0028	.0027
3	.0113	.0094	.0078	.0077	.0063	.0056	.0053	.0048	.0048	.0044	.0043	.0039	.0039	.0039	.0039	.0036	.0031	.0028	.0028	.0022	.0020
4	.0095	.0079	.0067	.0059	.0053	.0047	.0045	.0041	.0042	.0037	.0036	.0034	.0033	.0032	.0031	.0031	.0026	.0024	.0020	.0020	.0019
5	.0084	.0070	.0058	.0050	.0047	.0042	.0039	.0036	.0036	.0033	.0032	.0029	.0029	.0028	.0027						
6	.0076	.0063	.0052	.0045	.0043	.0037	.0036	.0031	.0032	.0030	.0029	.0026	.0026	.0025							
7	.0070	.0058	.0048	.0041	.0039	.0034	.0031	.0028	.0029	.0027	.0026	.0024	.0024	.0023							
8	.0065	.0054	.0045	.0038	.0036	.0032	.0030	.0026	.0027	.0025	.0024	.0022	.0022								
9	.0061	.0051	.0042	.0036	.0034	.0030	.0029	.0025	.0026	.0024	.0023	.0021									
10	.0057	.0048	.0040	.0034	.0032	.0028	.0028	.0024	.0025	.0023	.0022	.0020									
11	.0054	.0045	.0038	.0032	.0031	.0027	.0027	.0023	.0023	.0022	.0021										
12	.0052	.0043	.0036	.0031	.0029	.0026	.0026	.0022	.0022	.0021											
13	.0049	.0042	.0035	.0030	.0027	.0025	.0025	.0021													
14	.0048	.0041	.0034	.0029	.0026	.0024	.0024	.0020													
15	.0046	.0040	.0033	.0028	.0025	.0023															
16	.0044	.0039	.0032	.0027	.0025	.0022															
17	.0043	.0038	.0031	.0026																	
18	.0042	.0037	.0030	.0025																	
19	.0041																				
20	.0039																				

Recommended Infeed Values for Internal UN Threads - Steel

No. Of Passes	TPI																				
	4	5	6	7	8	9	10	11	12	13	14	16	18	20	24	28	32	36	40	44	48
1	.0303	.0255	.0213	.0183	.0169	.0150	.0145	.0132	.0131	.0120	.0117	.0107	.0106	.0102	.0101	.0096	.0084	.0075	.0067	.0061	.0056
2	.0125	.0105	.0090	.0076	.0073	.0062	.0064	.0055	.0054	.0050	.0048	.0043	.0044	.0042	.0042	.0039	.0035	.0031	.0029	.0025	.0023
3	.0096	.0083	.0069	.0058	.0053	.0047	.0046	.0044	.0041	.0038	.0037	.0034	.0033	.00323	.0032	.0033	.0027	.0023	.0021	.0019	.0017
4	.0081	.0068	.0057	.0049	.0047	.0040	.0038	.0035	.0035	.0032	.0031	.0028	.0028	.0027	.0027	.0025	.0023	.0021	.0018	.0018	.0011
5	.0071	.0060	.0050	.0043	.0041	.0035	.0034	.0031	.0031	.0028	.0027	.0025	.0025	.0024	.0023						
6	.0064	.0054	.0045	.0039	.0036	.0032	.0031	.0028	.0028	.0025	.0025	.0029	.0023	.0022							
7	.0059	.0050	.0041	.0036	.0033	.0029	.0028	.0026	.0026	.0023	.0023	.0021	.0021	.0021							
8	.0055	.0046	.0038	.0033	.0030	.0027	.0026	.0024	.0024	.0022	.0021	.0020	.0029								
9	.0052	.0043	.0036	.0031	.0028	.0025	.0024	.0022	.0022	.0021	.0020	.0019									
10	.0049	.0041	.0034	.0029	.0027	.0024	.0023	.0022	.0022	.0020	.0019	.0018									
11	.0046	.0039	.0032	.0028	.0026	.0023	.0022	.0020	.0020	.0019	.0018										
12	.0044	.0037	.0031	.0027	.0025	.0022	.0021	.0019	.0019	.0018											
13	.0042	.0036	.0030	.0026	.0024	.0021	.0020	.0018													
14	.0041	.0035	.0029	.0025	.0023	.0020	.0019	.0017													
15	.0040	.0034	.0028	.0024	.0022	.0019															
16	.0039	.0033	.0027	.0023	.0021	.0019															
17	.0038	.0032	.0026	.0022																	
18	.0037	.0031	.0025	.0021																	
19	.0036																				
20	.0035																				

Note: Information provided in these charts and found using the formulas on the preceding page are to be used as a starting point only and may need to be adjusted to accommodate actual working conditions.

Grooving Methods

Internal/External Grooving

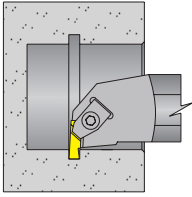

Profiling

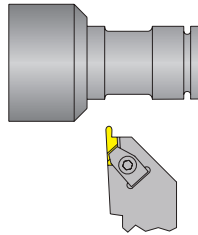

Undercutting

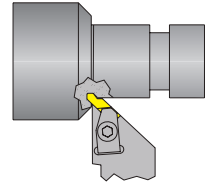

Always make sure that the toolholder is held at a 90° angle to the material being turned.

Insert center height should be kept at the center line of the workpiece to .005 above the centerline

For best results keep the feed rate between .003 and .012 ipr

Dwell tool in bottom of cut no more than three revolutions.

Grooving

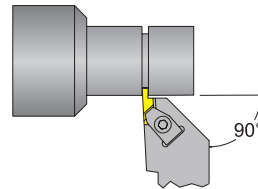

Back Turning

Insert center height should be kept at the center line of the workpiece to .005 above the centerline

For best results keep the feed rate between .003 and .012 ipr

Maximum depth of cut should be kept below .110 for .250 IC inserts and .150 for .375 IC inserts

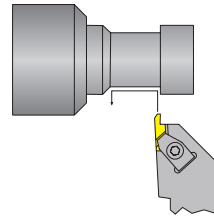

Wide Grooves

Plunge both sides of the groove width first.

Plunge the center area to clean out the remaining material.

If angled walls are required for the groove, perform as a final operation.

For best results keep the feed rate between .003 and .012 ipr

See profiling to finish the groove.

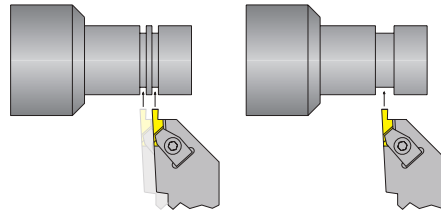

Profiling

Rough the profile as if cutting a wide groove.

Plunge from each end and turn to the center of the profile in order to ensure wall perpendicularity

If using a radius insert, depth of cut should not exceed the insert radius size.

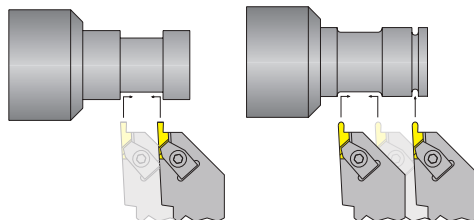

Threading & Grooving Application Data Chart

Material Application	Non Ferrous	Ferrous	Ferrous & Non Ferrous	Insert Rake
Insert Coating	PVD+TiN	PVD+TiN	PVD-TiN+TiAlN+TiN	
Industry standard Insert Grade	(A.N.S.I. - C3-C4, C7-C8) (I.S.O. - K05-K15, K05-, K10-K30)	(A.N.S.I. - C5-C6) (I.S.O. - P15-P35, M20-M35)	(A.N.S.I. - C2-C3, C6-C7) (I.S.O. - K05-K25, K15-K35)	
Dorian Insert Grade	DVK10	DVP656	DASK25B	
	<i>Sharper Edge</i>	<i>Honed Edge</i>	<i>Honed Edge</i>	
Material to be Machined	Recommended Surface Speed per Minute - $\frac{\text{Feet}}{\text{min}}$ - sfm (Vc)			
Low Carbon Steel and free Machining Steel		250 - 450 (76 - 137)	300 - 500 (91 - 152)	Negative
Carbon steel, Alloy Steel and Tool Steel <35 HCR		200 - 400 (61 - 122)	250 - 500 (76 - 152)	Negative
Carbon Steel, Alloy Steel and Tool Steel >35 HCR		150 - 500 (46 - 152)	200 - 400 (61 - 122)	Negative
Martensitic- Ferritic, 400 Series and PH Stainless Steel		150 - 350 (46 - 107)	150 - 400 (46 - 122)	Negative
Stainless Steel Austenitic 200 and 300 Series	200 - 650 (61 - 198)		200 - 500 (61 - 152)	Negative
Gray Cast Iron 135-270 BHN	200 - 750 (61 - 229)		200 - 600 (61 - 183)	Negative
Gray Cast Iron 275-450 BHN	150 - 575 (46 - 175)		150 - 450 (46 - 137)	Negative
Ductile Cast Iron	150 - 650 (46 - 198)		150 - 500 (46 - 152)	Negative
Free Machining Aluminum, Low Silicon Aluminum < 12.2%, Magnesium 50-90 BHN	400 - 1200 (122 - 366)		400 - 1000 (122 - 305)	Positive
High Silicon Aluminum < 12.2%	-		-	Positive
Copper, Brass, Bronze, Zinc, Lead Alloys, Magnesium 90-150 BHN	250 - 1000 (76 - 305)		250 - 800 (76 - 244)	Positive
Carbon and Graphite 270-400 BHN Nylon, Plastics, Rubberes, Phenolics, Resins	400 - 1300 (122 - 397)		400 - 1500 (122 - 458)	Positive
Cobalt Base High Temper Alloys 50-425 BHN	75 - 400 (23 - 122)		75 - 300 (23 - 91)	Positive
Iron Base High Temper Alloys 135-320 BHN	75 - 400 (23 - 122)		75 - 300 (23 - 91)	Positive
Nickle Base High Temper Alloys 140-300 BHN	100 - 250 (31 - 76)		100 - 200 (31 - 61)	Positive
Nickle Base High Temper Alloys 300-475 BHN	100 - 250 (31 - 76)		100 - 200 (31 - 61)	Positive
Titanium Alloys 100-475 BHN	110 - 325 (34 - 99)		110 - 250 (34 - 76)	Positive

Surface Feed Per Minute Formula - sfm

	sfm-Inch	sfm-Metric
D_m = Diameter of Part - DIA	$V_c = \frac{\pi \times D_m \times n}{12}$	$V_c = \frac{\pi \times D_m \times n}{1000}$
n = Spindle Speed - RPM	$n = \frac{V_c \times 12}{\pi \times D_m}$	$n = \frac{V_c \times 1000}{\pi \times D_m}$
V_C = Surface Feed per Minute - sfm		

Trouble Shooting

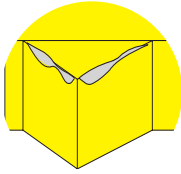
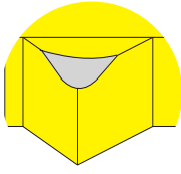
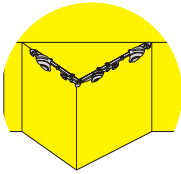
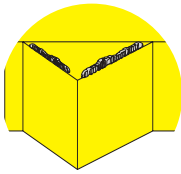
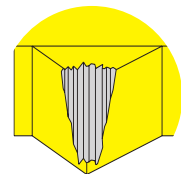
Problem	Cause	Solution
 <p>Edge Wear</p>	<ul style="list-style-type: none"> • Cutting speed too high • Infeed depth too shallow • Insert is above center line 	<ul style="list-style-type: none"> • Increase feeds • Adjust center ceights • Reduce speed • Use insert with more wear resistant grade
 <p>Heat Deformation</p>	<ul style="list-style-type: none"> • Cutting temperature too high • Pressure too high • Not enough coolant 	<ul style="list-style-type: none"> • Reduce speed • Reduce feed • Reduce the largest infeed depth • Increase coolant flow
 <p>Chipping</p>	<ul style="list-style-type: none"> • Excessive load • Infeed depths too shallow 	<ul style="list-style-type: none"> • Change edge preparation • Check rigidity of the insert • Reduce speed • Use insert with a more wear resistance grade
 <p>Built-up Edge</p>	<ul style="list-style-type: none"> • Cutting temperature too low • Low cutting speed • Negative cutting geometry 	<ul style="list-style-type: none"> • Increase feed • Increase speed • Apply coolant at a constant rate
 <p>Insert Breakage</p>	<ul style="list-style-type: none"> • Grade too brittle • Excessive load • Weak insert geometry • Insert too small 	<ul style="list-style-type: none"> • Reduce depth of cut • Reduce speed and feed • Apply coolant at a constant rate • Check ridigity of the insert • Use stronger insert geometry

Threading Problems & Solutions

Torn Thread Finish	Shallow Thread Finish	Poor Surface Quality	Chatter
<ol style="list-style-type: none"> 1. Use full profile insert 2. Check for insert wear 3. Modify infeed 4. Increase coolant flow and pressure 	<ol style="list-style-type: none"> 1. Adjust tool center height 2. Check workpiece diameter 3. Index the insert 	<ol style="list-style-type: none"> 1. Increase cutting speed 2. Adjust tool center height 3. Use alternate infeed angle 	<ol style="list-style-type: none"> 1. Use minimum tool overhang 2. Adjust tool center height 3. Check for deflection 4. Check for insert, toolholder, and material rigidity

Threading and Grooving Insert Grades

Material	Dorian Grade	Coating Specifications	ANSI	ISO	Insert Grade Specifications
					Ferrous Material
<p>P</p> <p>Free Cutting Steel, Low Carbon Steel, Alloy Carbon Steel, Tool Steel, Under 35HRC, Ferretic Stainless Steel 400</p>	DVP656	PVD-TiN	<p>C5-C6</p>	<p>P15-P35</p> <p>M20-M35</p>	<p>Well balanced substrate with cobalt enriched periphery, with a very good thermal resistance and mechanical shock. PVD TiN coating to dissipate friction and protect the cutting edge. First Choice For threading all ferrous material with medium cutting sfm</p>
<p>MNKS</p> <p>Aluminum, Stainless Steel, Cast Iron, Plastic Materials</p>	DVK10	PVD-TiN	<p>C3-C4</p>	<p>N05-N15</p> <p>M10-M30</p> <p>K05-K15</p>	<p>Fine micro-grained substrate with PVD-TiN coating, with high viscosity and with hard cutting edge and wear resistance to abrasion, First Choice for threading all the non ferrous metals at medium to high sfm. Use wet</p>
<p>MNKS</p> <p>Ferrous and Non Ferrous Material</p>	DASK25B	PVD TiN+TiAlN TiN Multi Layer	<p>C6-C7</p> <p>C2-C3</p>	<p>P5-P25</p> <p>M15-M35</p> <p>K15-K25</p> <p>S05-S25</p>	<p>Hard and tough ultra micro substrate, Multi layer hard coating PVD-TiN+TiAlN+TiN with high oxidation and wear resistance properties, enhancing high lubricity to avoid edge built up. First Choice for threading ferrous and non ferrous metals, and High Temper Alloyed Aerospace Materials. Threading operation on all the materials at high sfm. Use wet limit. Used wet or dry.</p>

On Edge Threading and Grooving Inserts

TNMA / TNMC

- NV 60° Thread **Pg. E-16**
- NT ACME Thread **Pg. E-16**
- NT Stub ACME Thread **Pg. E-16**
- NG Grooving **Pg. E-17**

TPMA / TPMC

- NV 60° Thread **D-18**
- NT ACME Thread **D-18**
- NT Stub ACME Thread **D-18**
- NG Grooving **D-19**

On Edge API

API - TNMA / TNMC

- API Buttress Thread **Pg. E-38**
- API Hughes H90 Thread **Pg. E-38**
- API Rotary Shoulder Thread **Pg. E-38**
- API Round Thread **Pg. E-39**
- API VAM Thread **Pg. E-39**
- API X-Line Thread **Pg. E-39**



Laydown Threading Inserts

- 60° Partial Profile Thread **Pg. E-24**
- 60° Full Profile Thread **Pg. E-24**
- UN 60° Full Profile Mini. Thread **Pg. E-24**
- NTP-NPTF 60° Full Profile Mini. Thread **Pg. E-24**
- UN 60° Full Profile Thread **Pg. E-25-D-26**
- UN/UNJ 60° Full Profile Multi Tooth Thread **Pg. E-27**

- 29° ACME Thread **Pg. E-27**
- 29° Stub ACME Thread **Pg. E-28**
- NPT Full Profile Thread **Pg. E-28-D-29**
- NPTF Dryseal Thread **Pg. E-29**

Laydown API

- API Round Thread **Pg. E-40**
- API Buttress Casing Thread **Pg. E-40**
- API Rotary Shoulder Thread **Pg. E-40**
- API Hughes H90 Thread **Pg. E-40**
- API VAM Thread **Pg. E-41**
- API X-Line Thread **Pg. E-41**
- API VO55 Thread **Pg. E-41**
- API Round Multi Tooth Thread **Pg. E-41**
- API Standard Buttress Thread **Pg. E-42**
- API Push Buttress Thread **Pg. E-42**



API- Metric DIN

- API Buttress Thread **Pg. E-43**
- API 30° Round Thread **Pg. E-43**
- API MJ 60° Full Profile Thread **Pg. E-44**
- API PG 80° Full Profile Thread **Pg. E-44**

DorNotch Threading and Grooving Inserts

- NT 60° Partial Profile **Pg. E-32**
- NPT / NPTF 60° Partial Profile **Pg. E-32**
- NTK / NJ 60° Partial Profile **Pg. E-32**
- NA 29° ACME Thread **Pg. E-33**
- NAS 29° Stub ACME Thread **Pg. E-33**

- NU Grooving **Pg. E-33**
- NV Poly-Vee Grooving **Pg. E-33**
- NG Grooving **Pg. E-34**
- NGP Grooving **Pg. E-35**
- NR / NRP Full Radius Grooving **Pg. E-35**

DorNotch API

- API American Buttress Thread **Pg. E-46**
- API Rotary Shoulder Thread **Pg. E-46**
- API Round Thread **Pg. E-46**
- API Buttress Thread **Pg. E-46**



V-Bottom Threading and Grooving Inserts

- V84 / 85 60° Thread **Pg. 53**
- V84 / 85 29° ACME Thread **Pg. 53**
- V84 / 85 29° Stub ACME Thread **Pg. 53**
- V84 NPT (National Pipe Thread) **Pg. 53**
- NG Grooving **Pg. 53**

V-Bottom API

- API V84 Round Thread **Pg.68**
- API V84 Buttress Thread **Pg.68**
- API Hughes H90 Thread **Pg.68**
- API V85 Rotary Shoulder Thread **Pg.68**
- API V84 VAM Thread **Pg.68**
- API V84 X-Line Thread **Pg.68**



L-API Threading Inserts

- L43 / 53 - API Buttress Thread **Pg. E-47**
- L53 - API Hughes Thread H90 **Pg. E-47**
- LDS54 - API Hughes H90 Thread **Pg. E-47**
- L43 / 53 - API Rotary Shoulder **Pg. E-48**
- L43 / 53 - API Round Thread **Pg. E-48**
- LDS43 / 54 - API Round Thread **Pg. E-48**

- LDS54 - Double Sided Straight Topping Thread **Pg. E-49**
- LDS54 - Double Sided Follow Topping Thread **Pg. E-49**
- LPGC32 / 43 - API Round Thread **Pg. E-49**
- L43 - API VAM Thread **Pg. E-49**
- L43 - API X-Line Thread **Pg. E-49**



API Chaser Threading Inserts

- API Buttress Thread **Pg. E-50**
- API Buttress Thread SET **Pg. E-50**
- API Round Thread **Pg. E-50**
- API Round Thread SET **Pg. E-50**
- API Line Pipe Thread **Pg. E-50**



On Edge Toolholder Threading Method

EXTERNAL RIGHT HAND THREAD

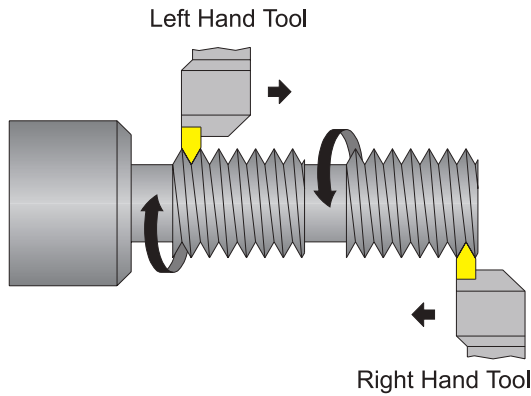

EXTERNAL LEFT HAND THREAD

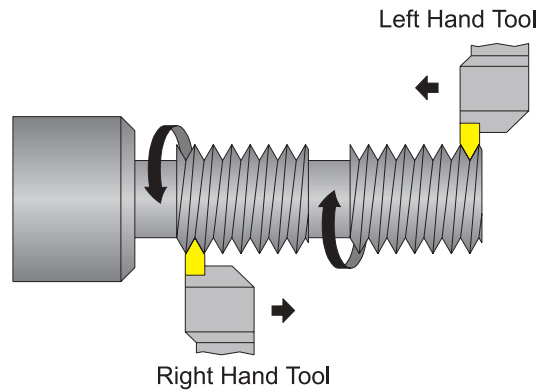

On Edge Threading Bar Threading Method

INTERNAL RIGHT HAND THREAD

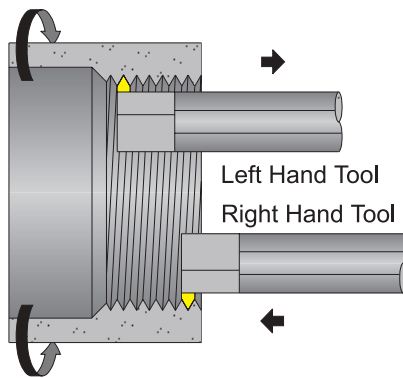

INTERNAL LEFT HAND THREAD

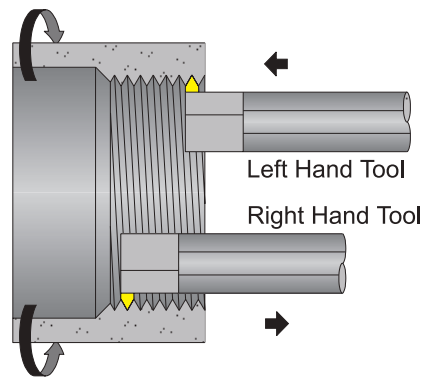

On Edge Gangtool Threading Method

INTERNAL RIGHT HAND THREAD

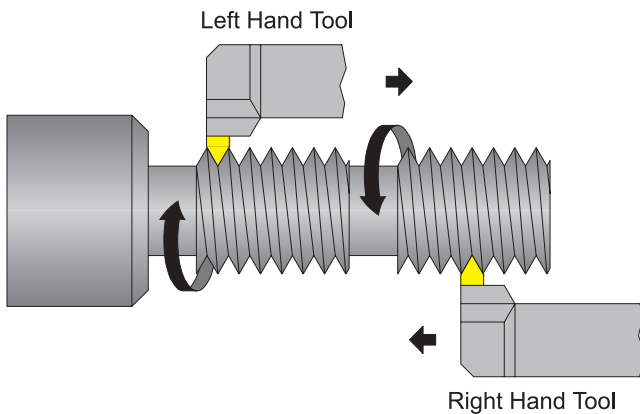

INTERNAL LEFT HAND THREAD

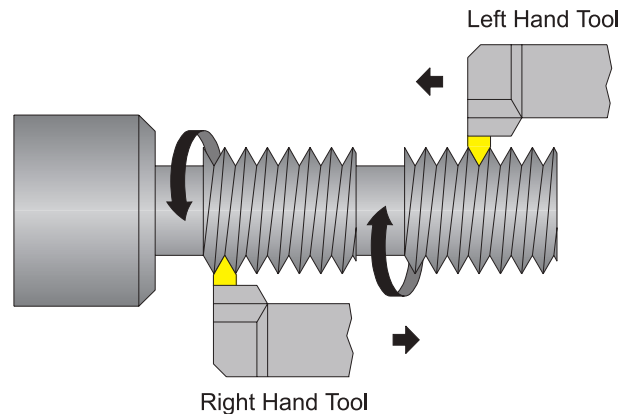

On Edge Threading Insert Identification System

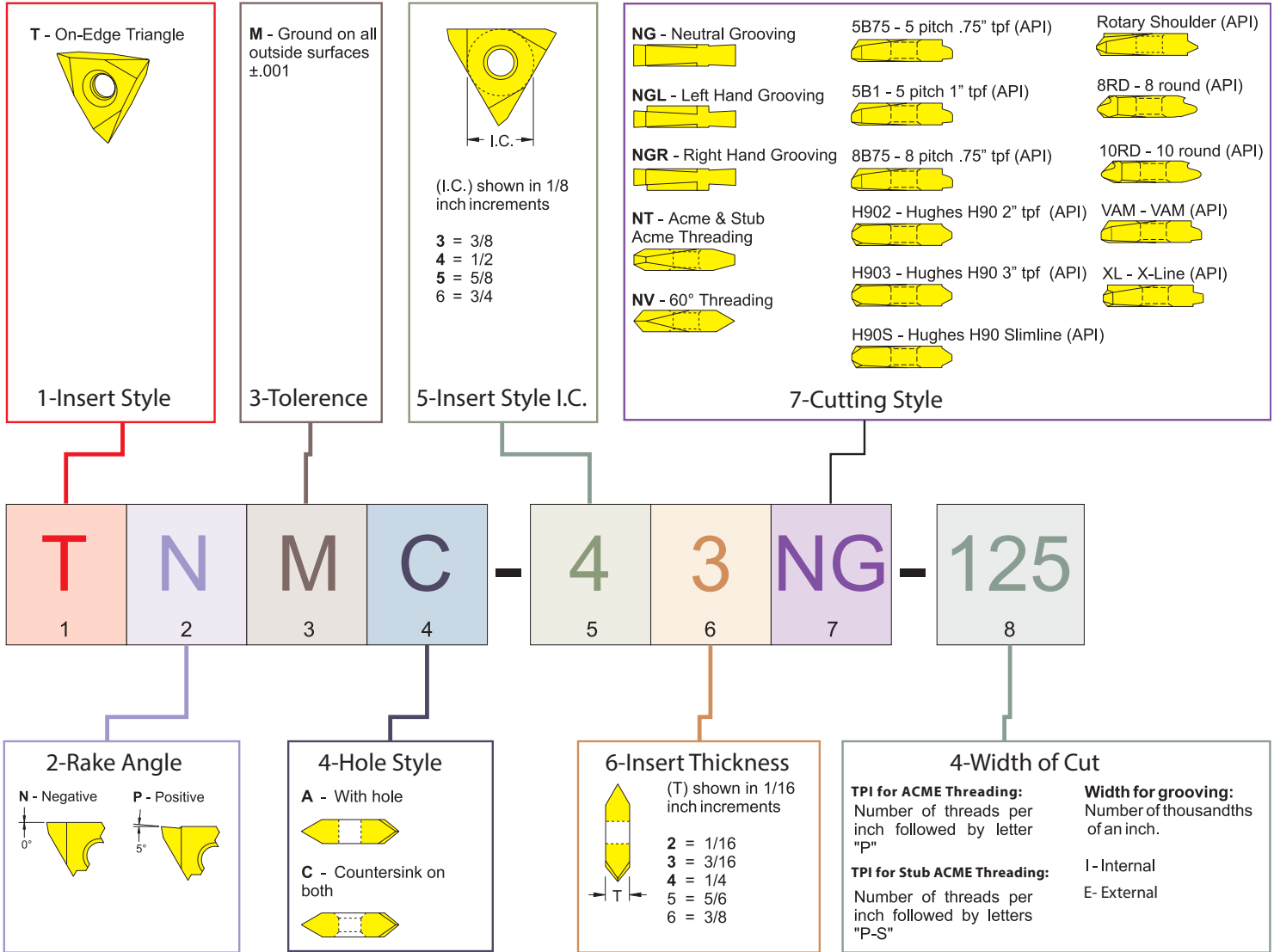

On Edge Threading Insert Grade & Application Chart

<p>Note: Threading information provided is for reference only.</p> <p>Actual Threading data will be determined in the application.</p>	Threading Application	Non Ferrous		Ferrous		Ferrous & Non Ferrous	
	VC	High		Medium		Very High	
	sfm	200"-600"	70-180mm	330"-750"	100-230mm	200"-2600"	61-362mm
	Condition	Wet		Wet		Dry-Wet	
	Industry standard Insert Grade	(A.N.S.I. -C1-C2) (I.S.O. -K15-K30)		(A.N.S.I. -C5-C6) (I.S.O. -P15-P35)		(A.N.S.I. - C3 C4) (I.S.O. - K10-K20)	
Insert Coating	PVD-TiN		PVD-TiN		PVD Multi-Layer		
Insert Grade Specifications	Hard micro-grained substrate with PVD-TiN coating, with high viscosity, hard cutting edge and wear resistance for machining with high sfm.		Well balanced substrate with a very good resistance to thermal and mechanical shock PVD-TiN coating, best finishing applications medium cutting sfm.		Ultra fine and hard micro-grained substrate with hard coating, enhancing sliding wear, load capacity with high lubricity to avoid edge built up. For precision threading operation at high sfm.		
Insert Aptitude	Wet Medium		Wet Toughness		Wet Wear Resistant		
Dorian Insert Grade	DVK10		DVP656		DASK25B		

On Edge TNMA-TNMC

	First Choice	General Purpose	General Purpose	High Performance
Material Application	Non Ferrous	Ferrous	Ferrous & Non Ferrous	
	Stainless Steel, Cast Iron, Aluminum & H.T.A.	Carbon Steel, Alloy Steel & Stainless Steel	Carbon Steel, Alloy Steel & Stainless Steel , Cast Iron, Aluminum & H.T.A.	
Dorian Insert Grade	DVK10	DVP656	DASK25B	



NV 60°	Inch Description				UPC No 733101-				Insert Dimensions				
	TNMA	TNMC	TNMA	TNMC	TNMA	TNMC	TNMA	TNMC	I.C.	Thick	Hole Dia.	Rad.	TPI
Threading Negative Rake	TNMA-32NV	TNMC-32NV	72529	72004	72528	72003	72530	72005	.375	.125	.150	.003 .005	8-36
	TNMA-43NV	TNMC-43NV	72536	72008	72535	72010	72537	72011	.500	.187	.203	.003 .005	5-24
	TNMA-43NV .010R	TNMC-43 NV .010R	72543	72018	72542	72017	72544	72019	.500	.187	.203	.010	4-20
	TNMA-54NV	TNMC-54NV	72557	72032	72556	72031	72558	72033	.625	.250	.250	.008 .010	4-20
	TNMA-54NV .010R	TNMC-54NV .010R	72564	72039	72563	72038	72565	72040	.625	.250	.250	.010	4-20

Please call to check availability of Inserts.

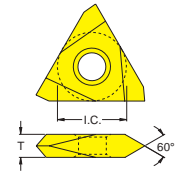

**On Edge
TPMA-TPMC**

	First Choice	General Purpose	General Purpose	High Performance	
Material Application	Non Ferrous		Ferrous	Ferrous & Non Ferrous	
	Stainless Steel, Cast Iron, Aluminum & H.T.A.		Carbon Steel, Alloy Steel & Stainless Steel	Carbon Steel, Alloy Steel & Stainless Steel, Cast Iron, Aluminum & H.T.A.	
Dorian Insert Grade	DVK10		DVP656	DASK25B	

NV 60°	Inch Description		UPC No 733101-				Insert Dimensions						
	TPMA	TPMC	TPMA	TPMC	TPMA	TPMC	TPMA	TPMC	I.C.	Thick	Hole Dia.	Rad.	TPI
Threading 5° Positive Rake	TPMA-32NV	TPMC-32NV	73394	73056	73393	73055	73395	73057	.375	.125	.150	.003 .005	8-36
	TPMA-43NV	TPMC-43NV	73401	73063	73400	73062	73402	73064	.500	.187	.203	.003 .005	5-24

Please call to check availability of Inserts.

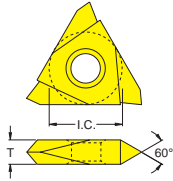

Laydown Toolholder Threading Method

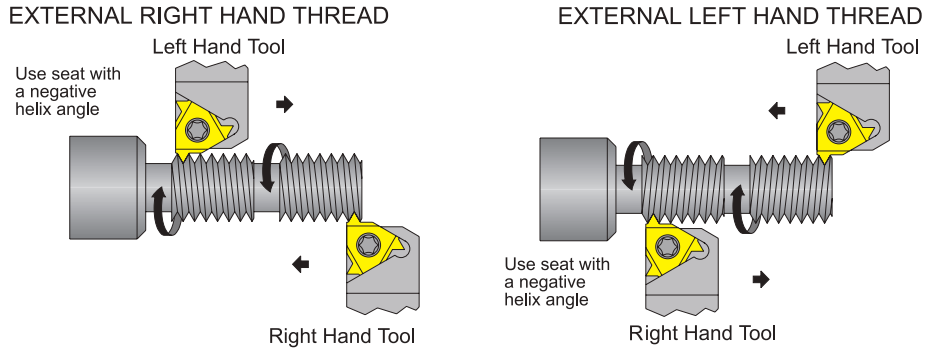

Laydown Threading Bar Threading Method

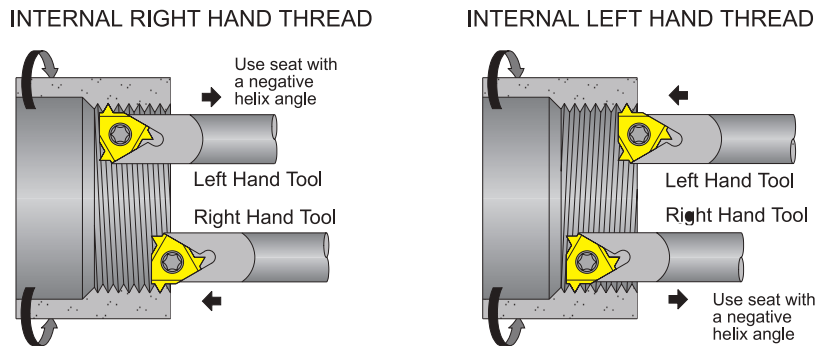

Laydown Threading Shim Seat Options

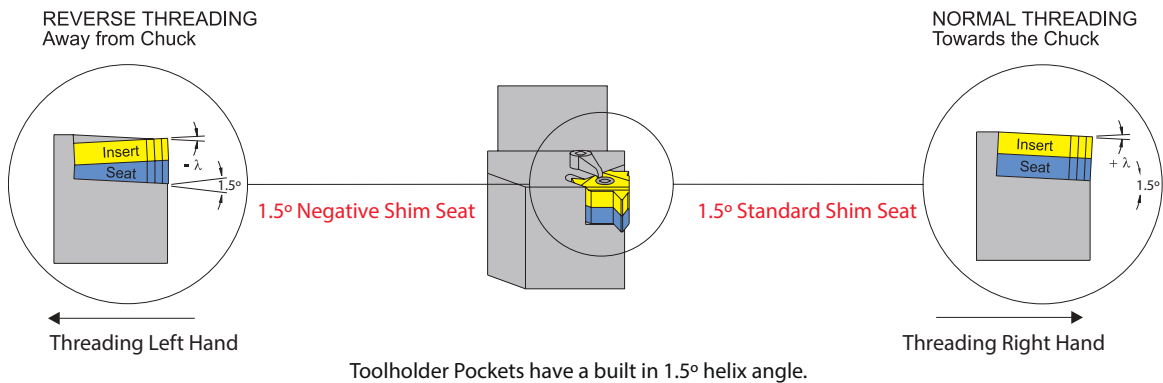

Full Profile vs Partial Profile for Laydown Threading	
<p>Full Profile</p>	<p>Partial Profile</p>
<ul style="list-style-type: none"> • Threads remain concentric since both the major and minor diameters are machined at the same time • Final pass machines the thread crest- No Deburring! • Thread dimensions match industry standard • Fewer passes required- saves time and improves productivity • Stronger insert for longer tool life 	<ul style="list-style-type: none"> • A variety of pitches may be created by a single insert • Provides for creating thread forms that are not industry standard • Requires a separate finishing pass to machine the thread crest and deburr the thread

Single Tooth vs Multi-Tooth for Laydown Threading			
<p>Single Tooth</p>		<p>Multi-Tooth</p>	
Pros	Cons	Pros	Cons
<ul style="list-style-type: none"> • Available in either full or partial inserts for greater variety of thread pitch option • Good chip control 	<ul style="list-style-type: none"> • A large number of passes is required to machine a full depth thread 	<ul style="list-style-type: none"> • Multiple teeth require a smaller number of passes to create a full depth thread • Increased tool life • Better productivity 	<ul style="list-style-type: none"> • Large clearance is needed to accommodate the full row of teeth • Extremely high cutting forces result from the large insert engagement length

Special Considerations for Laydown Threading	
<p>Thread Compatibility Internal and external threads can have different variables, such as depth and radii. This can lead to the incompatibility of the threads.</p>	
<p>Thread Cutting Rake The rake for Dorian's threading external toolholders is 10° and the rake for Dorian's internal threading bars is as follows: Insert Size 11, 16, 22 - 15° Insert Size 27 - 10° This difference in the rake angle for the internal and external threading tools allow for the radial clearance.</p>	
<p>Insert Configuration Inserts and threading tools should always match. The insert for an internal right hand boring bar must be an internal right hand insert.</p>	

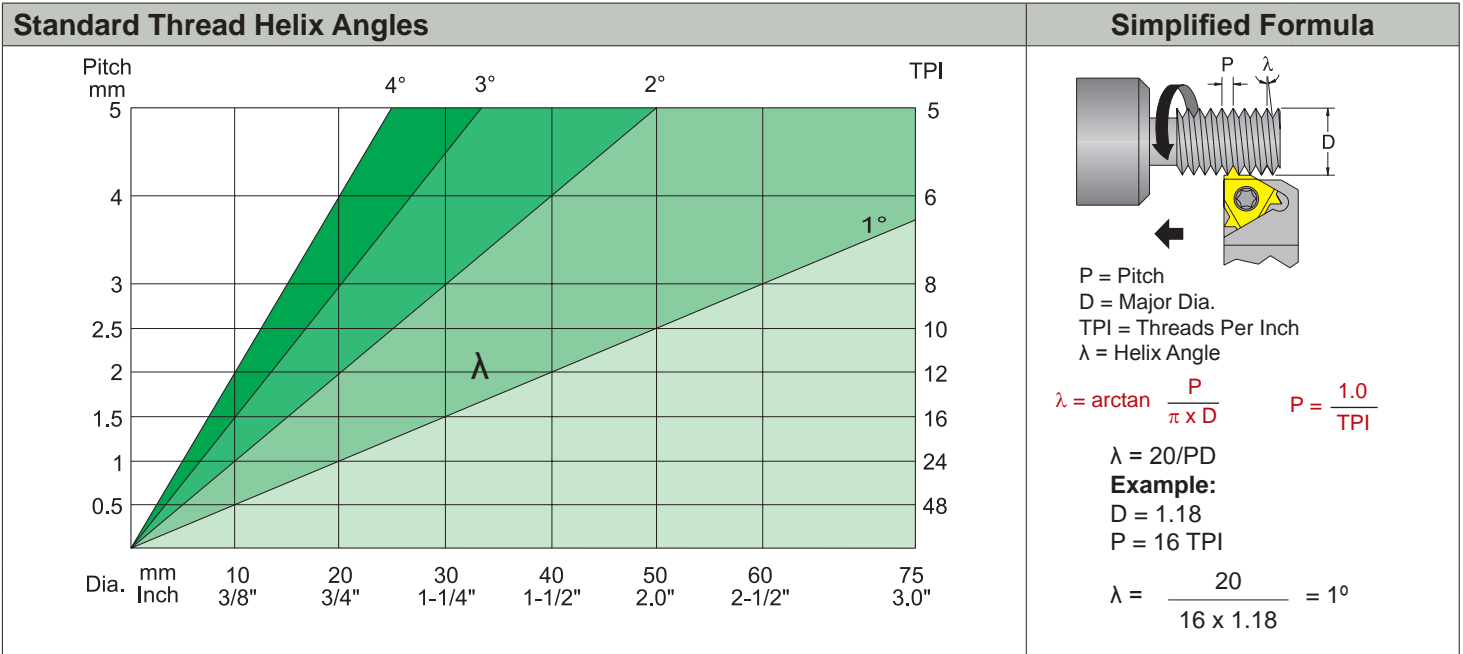

Standard and Slanted Shim Seats for Laydown Threading

Toolholders pockets have a built in 1.5° helix angle. This angle may be adjusted to better match the thread helix angle by simply changing the Shim Seat. Negative helix is usually used when threading RH thread with LH holder or LH thread with RH holder.

Insert Size		Slanted Shim Seat							Supplied		Negative Shim Seat	
		Helix Angle	4.5°		3.5°		2.5°		Standard Shim Seat		Negative Shim Seat	
L mm	I.C. Inch	Toolholders	Inch Description	UPC 733101-	Inch Description	UPC 733101-	Inch Description	UPC 733101-	Inch Description	UPC 733101-	Inch Description	UPC 733101-
16	3/8	EX-RH or IN-LH	GXE-16+4.5	92040	GXE-16+3.5	92050	GXE-16+2.5	92060	GXE/I-16	92070*	GXE-16-1.5	92077
16	3/8	EX-LH or IN-RH	GXI-16+4.5	92041	GXI-16+3.5	92051	GXI-16+2.5	92061			GXI-16-1.5	92078
22	1/2	EX-RH or IN-LH	NXE-22+4.5	92042	NXE-22+3.5	92052	NXE-22+2.5	92062	NXE/I-22	92071*	NXE-22-1.5	92079*
22	1/2	EX-LH or IN-RH	NXI-22+4.5	92043	NXI-22+3.5	92053	NXI-22+2.5	92063			NXI-22-1.5	92080
22U	1/2U	EX-RH or IN-LH	NXE-22U+4.5	92044	NXE-22U+3.5	92054	NXE-22U+2.5	92064	NXE-22U	92072	NXE-22U-1.5	92081
22U	1/2U	EX-LH or IN-RH	NXI-22U+4.5	92045	NXI-22U+3.5	92055	NXI-22U+2.5	92065	NXI-22U	95073	NXI-22U-1.5	92082
27	5/8	EX-RH or IN-LH	VXE-27+4.5	92046	VXE-27+3.5	92056	VXE-27+2.5	92066	VXE/I-27	92074*	VXE-27-1.5	92083*
27	5/8	EX-LH or IN-RH	VXI-27+4.5	92047	VXI-27+3.5	92057	VXI-27+2.5	92067			VXI-27-1.5	92084
27U	5/8U	EX-RH or IN-LH	VXE-27U+4.5	92048	VXE-27U+3.5	92058	VXE-27U+2.5	92068	VXE-27U	92075	VXE-27U-1.5	92085
27U	5/8U	EX-LH or IN-RH	VXI-27U+4.5	92049	VXI-27U+3.5	92059	VXI-27U+2.5	92069	VXI-27U	92076	VXI-27U-1.5	92086

EX = External, IN = Internal
UPC No.

*See crossover chart below for OLD Inch Description and New

Shim Seat Kits for Laydown Threading

Inch Description	UPC 733101-	Contents				
		4.5°	3.5°	2.5°	1.5°	-1.5°
GX16-SSK	92087	GXE-16+4.5	GXE-16+3.5	GXE-16+2.5	GXE-16	GXE-16-1.5
		GXI-16+4.5	GXI-16+3.5	GXI-16+2.5	GXI-16	GXI-16-1.5
NX22-SSK	92088	NXE-22+4.5	NXE-22+3.5	NXE-22+2.5	NXE-22	NXE-22-1.5
		NXI-22+4.5	NXI-22+3.5	NXI-22+2.5	NXI-22	NXI-22-1.5
NX22U-SSK	92089	NXE-22U+4.5	NXE-22U+3.5	NXE-22U+2.5	NXE-22U	NXE-22U-1.5
		NXI-22U+4.5	NXI-22U+3.5	NXI-22U+2.5	NXI-22U	NXI-22U-1.5
VX27-SSK	92090	VXE-27+4.5	-	VXE-27+2.5	-	VXE-27-1.5
		VXI-27+4.5	-	VXI-27+2.5	-	VXI-27-1.5
VX27U-SSK	92091	VXE-27U+4.5	-	VXE-27U+2.5	-	VXE-27U-1.5
		VXI-27U+4.5	-	VXI-27U+2.5	-	VXI-27U-1.5

Crossover Chart for NEW Shim Seat Inch Description

Old Desc.	Old UPC No. 733101-	NEW Desc.	NEW UPC No. 733101-
GX-16-1	90380	GXE/I-16	92070
NX-22-1	90381	NXE/I-22	92071
VX-27-1	90382	VXE/I-27	92074
NX-22-98	90386	NXE-22-1.5	92079
VX-27-98	90397	VXE-27-1.5	92083

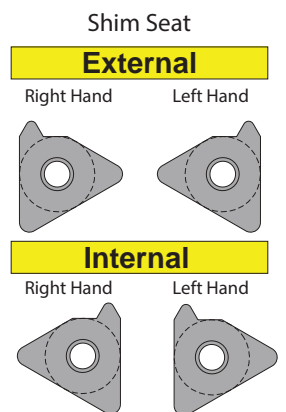

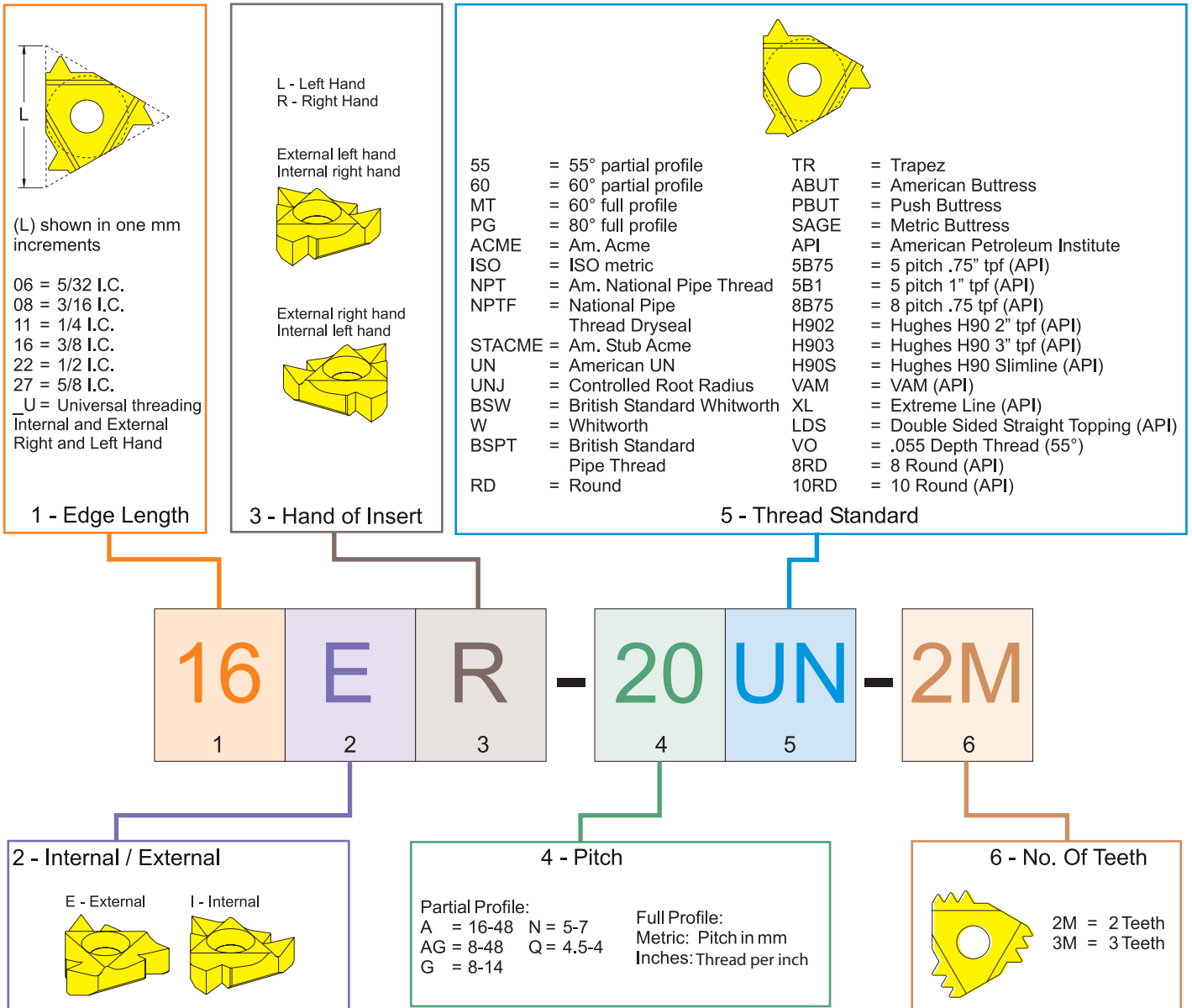

Laydown Threading Insert Grade & Application Chart

<p>Note: Threading information provided is for reference only.</p> <p>Actual Threading data will be determined in the application.</p>	Threading Application	Non Ferrous	Ferrous
	VC	High	Medium
	sfm	200"-600" 70-180mm	330"-750" 100-230mm
	Condition	Wet	Wet
	Industry standard Insert Grade	(A.N.S.I. -C1-C2) (I.S.O. -K15-K30)	(A.N.S.I. -C5-C6) (I.S.O. -P15-P35)
	Insert Coating	PVD-TiN	PVD-TiN
	Insert Grade Specifications	Hard micro-grained substrate with PVD-TiN coating, with high viscosity, hard cutting edge and wear resistance for machining with high sfm.	Well balanced substrate with a very good resistance to thermal and mechanical shock PVD-TiN coating, best finishing applications medium cutting sfm.
Insert Aptitude	Wet Medium	Wet Toughness	
Dorian Insert Grade	DVK10	DVP656	

Laydown

	First Choice	General Purpose	General Purpose	
Material Application	Ferrous & Non Ferrous		Ferrous	
	Carbon Steel, Alloy Steel & Stainless Steel, Cast Iron, Aluminum & H.T.A.		Carbon Steel, Alloy Steel & Stainless Steel	
Dorian Insert Grade		DVK10	DVP656	

60° Partial Profile	Inch Description		UPC No. 733101-				Insert Dimensions				Pitch	
	External Right	External Left	External Right	External Left	External Right	External Left	I.C. Inch	L mm	X mm	Y mm	TPI	mm
External Threading	11ER-A60	11EL-A60	74001	74005	74000	74004	.250	11	0,8	0,9	16-48	0,5-1,5
	16ER-A60	16EL-A60	74009	74013	74008	74012	.375	16	0,8	0,9	16-48	0,5-1,5
	16ER-G60	16EL-G60	74017	74021	74016	74020	.375	16	1,2	1,7	8-14	1,75-3,0
	16ER-AG60	16EL-AG60	74025	74029	74024	74028	.375	16	1,2	1,7	8-48	0,5-3,0
	22ER-N60	22EL-N60	74033	74037	74032	74036	.500	22	1,7	2,5	5-7	3,5-5,0
	27ER-Q60	27EL-Q60	74045	74049	74044	74048	.625	27	2,1	3,1	4-4,5	5,5-6,0

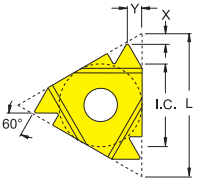

60° Partial Profile	Internal Right		Internal Left		Internal Right		Internal Left		Insert Dimensions			
	Internal Right	Internal Left	Internal Right	Internal Left	Internal Right	Internal Left	I.C. Inch	L mm	X mm	Y mm	TPI	MM
Internal Threading	06IR-A60	06IL-A60	74113	74117	74115	74119	.156	6,9	0,6	0,6	16-48	0,5-1,5
	08IR-A60	08IL-A60	74121	74125	74123	74127	.187	8,7	0,6	0,7	16-48	0,5-1,5
	11IR-A60	11IL-A60	74057	74061	74056	74060	.250	11	0,8	0,9	16-48	0,5-1,5
	16IR-A60	16IL-A60	74065	74069	74064	74068	.375	16	0,8	0,9	16-48	0,5-1,5
	16IR-G60	16IL-G60	74073	74077	74072	74076	.375	16	1,2	1,7	8-14	1,75-3,0
	16IR-AG60	16IL-AG60	74081	74085	74080	74084	.375	16	1,2	1,7	8-48	0,5-3,0
	22IR-N60	22IL-N60	74089	74093	74088	74092	.500	22	1,7	2,5	5-7	3,5-5,0
	27IR-Q60	27IL-Q60	74101	74105	74100	74104	.625	27	2,1	3,1	4-4,5	5,5-6,0

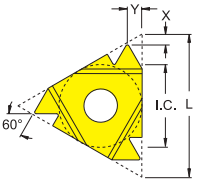

Please call to check availability of Inserts.

DorNotch Toolholder Threading Method

EXTERNAL RIGHT HAND THREAD

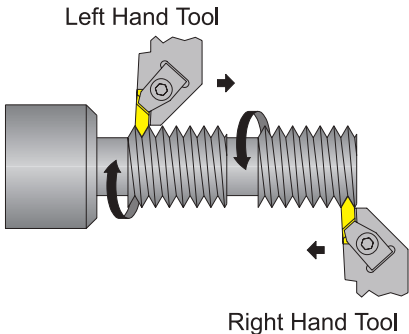

EXTERNAL LEFT HAND THREAD

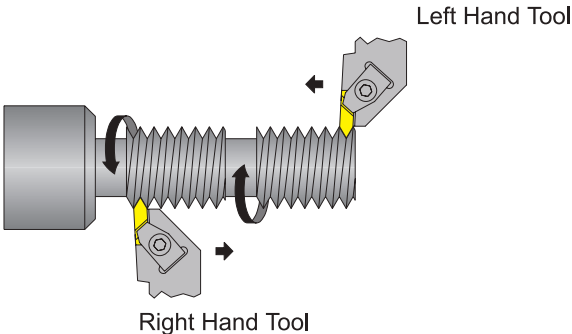

DorNotch Threading Bar Threading Method

INTERNAL RIGHT HAND THREAD

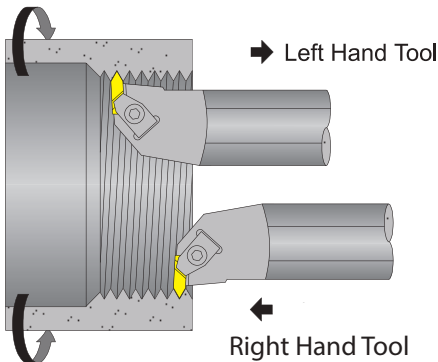

INTERNAL LEFT HAND THREAD

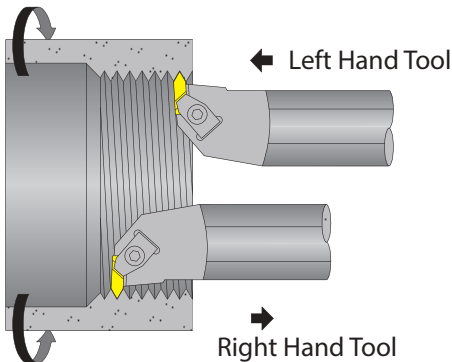

DorNotch Gangtool Threading Method

EXTERNAL RIGHT HAND THREAD

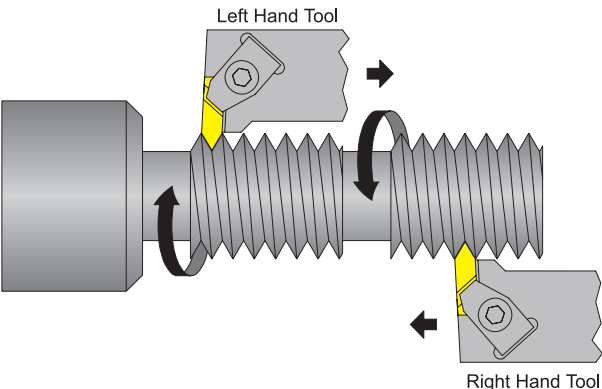

EXTERNAL LEFT HAND THREAD

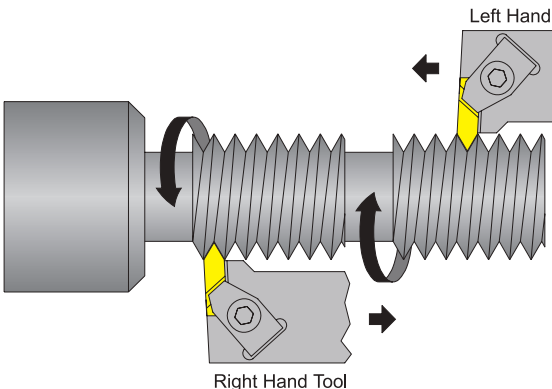

DorNotch Threading Inserts

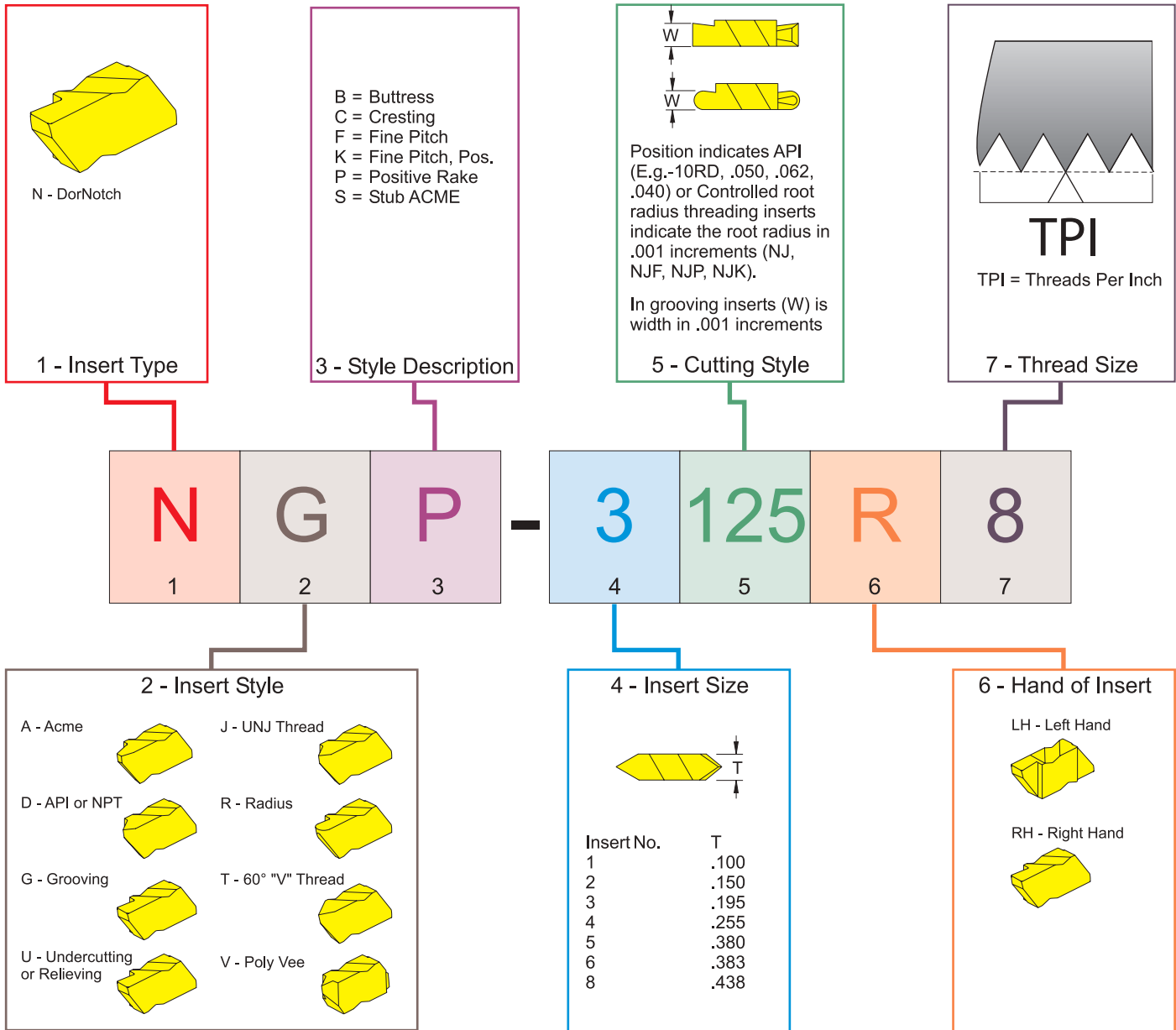

DorNotch Threading Insert Grade & Application Chart

Note: Threading information provided is for reference only. Actual Threading data will be determined in the application.	Threading Application	Non Ferrous	Ferrous	Ferrous & Non Ferrous		
	VC	High	Medium	Very High		
sfm	200"-600"	70-180mm	330"-750"	100-230mm	200"-2600"	61-362mm
Condition	Wet	Wet	Wet	Dry-Wet		
Industry standard Insert Grade	(A.N.S.I. -C1-C2) (I.S.O. -K15-K30)	(A.N.S.I. -C5-C6) (I.S.O. -P15-P35)	(A.N.S.I. -C3 C4) (I.S.O. -K10-K20)			
Insert Coating	PVD-TiN	PVD-TiN	PVD Multi-Layer			
Insert Grade Specifications	Hard micro-grained substrate with PVD-TiN coating, with high viscosity, hard cutting edge and wear resistance for machining with high sfm.	Well balanced substrate with a very good resistance to thermal and mechanical shock PVD-TiN coating, best finishing applications medium cutting sfm.	Ultra fine and hard micro-grained substrate with hard coating, enhancing sliding wear, load capacity with high lubricity to avoid edge built up. For precision threading operation at high sfm.			
Insert Aptitude	Wet Medium	Wet Toughness	Wet Wear Resistant			
Dorian Insert Grade	DVK10	DVP656	DASK25B			

DorNotch V Thread

	First Choice	General Purpose	General Purpose	High Performance
Material Application	Non Ferrous	Ferrous	Ferrous & Non Ferrous	
	Stainless Steel, Cast Iron, Aluminum & H.T.A.	Carbon Steel, Alloy Steel & Stainless Steel	Carbon Steel, Alloy Steel & Stainless Steel, Cast Iron, Aluminum & H.T.A.	
Dorian Insert Grade	DVK10	DVP656	DASK25B	



NT - 60°	Inch Description		UPC No.733101-				Insert Dimensions					Pitch						
	NT Right	NT Left	NT Right	NT Left	NT Right	NT Left	NT Right	NT Left	Gage Dia.	A IN	B IN	E IN	R IN	T IN	EXT. IN	INT. IN	EXT. mm	INT. mm
Partial Profile Negative Rake Angle	NT-2R	NT-2L	82901	82905	82900	82904	82902	82906	.1875	.219	.2661	.075	.003 .005	.150	8-36	7-20	0,70	3
	NT-3R	NT-3L	82909	82913	82908	82912	82910	82914	.3750	.344	.3999	.098	.005 .008	.195	6-20	5-12	1,25	4
	NT-4R	NT-4L	82917	82921	82916	82920	82918	82922	.3750	.453	.6239	.128	.005 .008	.255	4-20	4-12	1,00	4

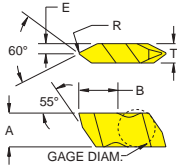

Please call to check availability of Inserts.



API & Oil Field Threading Inserts

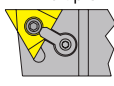
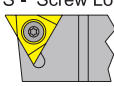
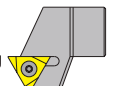
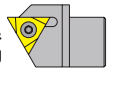

On Edge Threading Toolholder Identification System

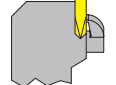
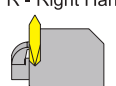
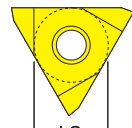
<p>M - Multiple Lock</p>  <p>S - Screw Lock</p>  <p>1 - Holding Method</p>	<p>H - Offset shank for I.D. threading & shallow grooving</p>  <p>V - Offset shank for O.D. threading & shallow grooving</p>  <p>Z - Offset shank for reverse hand threading & shallow grooving</p>  <p>3 - Tool Style</p>	<p>L - Left Hand</p>  <p>R - Right Hand</p>  <p>5 - Hand Of Tool</p>	 <p>(I.C.) shown in 1/8 inch increments</p> <p>3 = 3/8 4 = 1/2 5 = 5/8</p> <p>7 - Insert Size I.C.</p>
---	--	---	--

M **T** **V** **O** **R** **16** - **4** **D**

1 2 3 4 5 6 7 8

2 - Insert shape

T - Triangle



4 - Rake Attitude

N - Negative



O - Neutral



P - Positive



6 - Shank Size

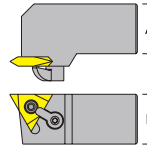



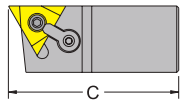

(A) & (B) shown in 1/16 inch increments

8 - Tool Length

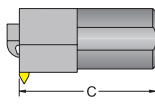

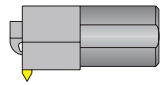
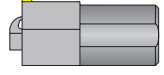
J - 3-1/2" D - 6.0
A - 4.0" E - 7.0
B - 4-1/2" F - 8.0
C - 5.0"

<p>C - Carbide S - Steel</p> <p>1 - Bar Type</p>	 <p>H - 4.0" S - 10.0 J - 4-1/2" T - 12.0 K - 5.0" U - 14.0 M - 6.0" V - 16.0 R - 8.0" Y - 18.0</p> <p>3 - Bar Length</p>	<p>M - Multiple Lock</p>  <p>S - Screw Lock</p>  <p>4 - Holding Method</p>	<p>H - Offset shank for I.D. threading & shallow grooving</p>  <p>6 - Tool Style</p>	<p>L - Left Hand</p>  <p>R - Right Hand</p>  <p>8 - Hand Of Tool</p>
---	---	---	---	---

S **16** **T** - **M** **T** **H** **O** **R** - **4**

1 2 3 4 5 6 7 8 9

2 - Shank Size

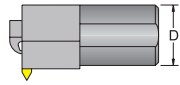

(D) shown in 1/16 inch increments

5 - Insert shape

T - Triangle



7 - Rake Attitude

N - Negative



O - Neutral



P - Positive



9 - Insert Size I.C.

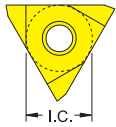

(I.C.) shown in 1/8 inch increments

3 = 3/8 5 = 5/8
4 = 1/2

MTVO-A R/L Threading Toolholder- Style V - O.D. Threading and Shallow Grooving for triangle TNMA inserts

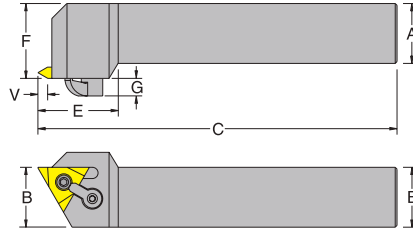
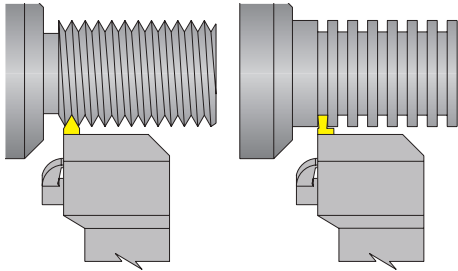

Right Hand Shown, Left Hand Opposite.

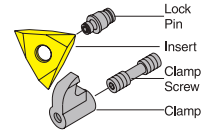

Inch Description	UPC No. 733101-		A	B	C	E	F	G	Max. GRV Depth V	TNMA Gage Insert	Lock Pin	Clamp	Clamp Screw
	R.H.	L.H.											
MTVOR/L08-3A-A	58122	58123	0.500	0.500	4.000	1.000	0.625	0.250	0.150	322	NL-33	CL-6	XNS-36
MTVOR/L08-3B-A	58126	58127	0.500	0.500	4.500	1.000	0.625	0.250	0.150				
MTVOR/L10-3B-A	58130	58131	0.625	0.625	4.500	1.000	0.750	0.250	0.150				
MTVOR/L12-3B-A	58134	-	0.750	0.750	4.500	1.000	0.875	0.250	0.150				
MTVOR/L16-3D-A	58138	58139	1.000	1.000	6.000	1.250	1.250	0.250	0.150				
MTVOR/L12-4B-A	58142	58143	0.750	0.750	4.500	1.250	0.875	0.250	0.230	432	NL-44	CL-6	XNS-36
MTVOR/L16-4D-A	58146	58147	1.000	1.000	6.000	1.250	1.250	0.250	0.230				
MTVOR/L20-4D-A	58150	58151	1.250	1.250	6.000	1.250	1.500	0.250	0.230				
MTVOR/L24-4E-A	58154	-	1.500	1.500	7.000	1.250	1.750	0.250	0.230				
MTVOR/L16-5D-A	58158	58159	1.000	1.000	6.000	1.500	1.250	0.250	0.292	543	NL-56	CL-6	XNS-36
MTVOR/L20-5D-A	58162	58163	1.250	1.250	6.000	1.500	1.500	0.250	0.292				
MTVOR/L20-64D-A	58166	58167	1.250	1.250	6.000	1.750	1.500	0.316	0.360				
MTVOR/L20-66D-A	58170	58171	1.250	1.250	6.000	1.750	1.500	0.316	0.360	663	NL-66L	CL-12	XNS-59

For On Edge inserts see pages D-16 - E-19. For spare part see Page E-70.

MTHO-A R/L Threading Toolholder- Style H - Gang Toolholder for Shallow Grooving or I.D. Threading for triangle TNMA inserts

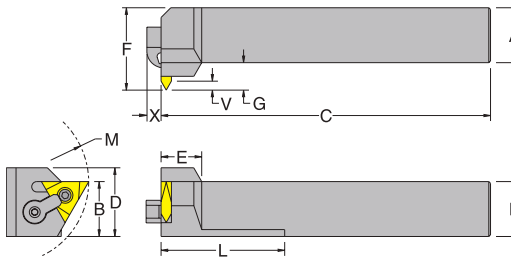
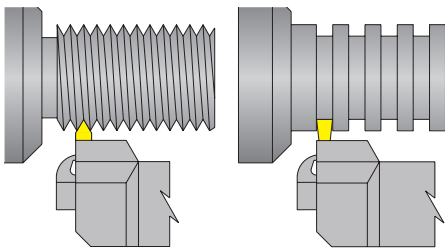

Right Hand Shown, Left Hand Opposite.

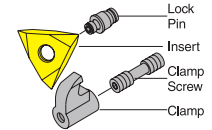

Inch Description	UPC No. 733101-		A	B	C	E	F	G	X	L	Min. Bore M	Max. GRV Depth V		TNMA Gage Insert	Lock Pin	Clamp	Clamp Screw
	R.H.	L.H.										Min. I.D.	O.D.				
MTHOR/L10-3B	58176	58177	0.625	0.625	4.500	0.875	1.000	0.375	0.250	-	2.0	.100	.125	322	NL-33	CL-5	XNS-35
MTHOR/L12-3B	58178	58179	0.750	0.750	4.500	0.875	1.125	0.375	0.250	1.50	3.0	.125	.194	432	NL-44	CL-6	XNS-36
MTHOR/L12-4B	-	58181	0.750	0.750	4.500	0.875	1.250	0.500	0.250	-							
MTHOR/L16-4D	58182	58183	1.000	1.000	6.000	0.875	1.500	0.500	0.250	2.00	3.0	.170	.242	543	NL-56	CL-6	XNS-36
MTHOR/L16-5D	58186	-	1.000	1.000	6.000	1.000	1.500	0.625	0.250	2.50							
MTHOR/L20-5D	58188	58189	1.250	1.250	6.000	1.000	1.750	0.625	0.250	2.50							

For On Edge inserts see pages D-16 - E-19. For spare part see Page E-70.

MTZO R/L Threading Toolholder- Style Z - Reverse Hand Threading for triangle TNMA inserts

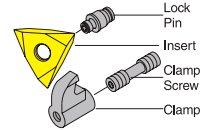
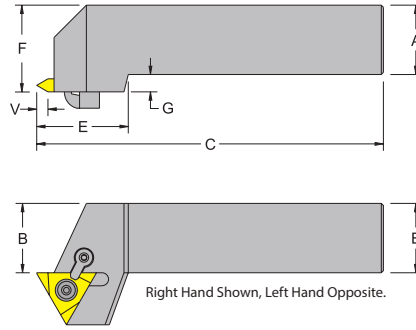
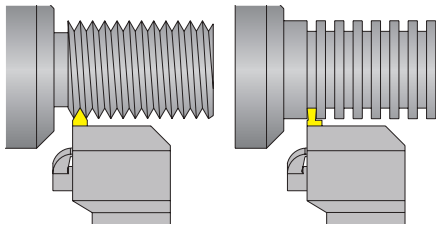

Inch Description	UPC No. 733101-		A	B	C	E	F	G	Max. GRV Depth V	TNMA Gage Insert	Lock Pin	Clamp	Clamp Screw
	R.H.	L.H.											
MTZOR/L12-3B	58260	58261	0.750	0.750	4.500	1.000	1.000	0.250	0.150	322	NL-33	CL-6	XNS-36
MTZOR/L16-4D	58268	58269	1.000	1.000	6.000	1.320	1.250	0.250	0.230	432	NL-44	CL-7	XNS-36
MTZOR/L20-4D	-	58273	1.250	1.250	6.000	1.320	1.500	0.250	0.230				
MTZOR/L20-66D	58284	58285	1.250	1.250	6.000	1.750	1.500	0.250	0.360	663	NL-66L	CL-30	XNS-510
MTZOR/L24-66E	58288	-	1.500	1.500	7.000	1.750	2.000	0.500	0.360				

For On Edge inserts see pages D-16 - E-19. For spare part see Page E-70.

MTVO-CN R/L Threading Toolholder- Style V - O.D. Threading and Shallow Grooving for triangle TNMC inserts

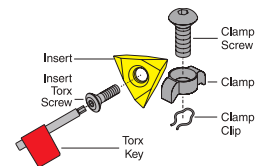
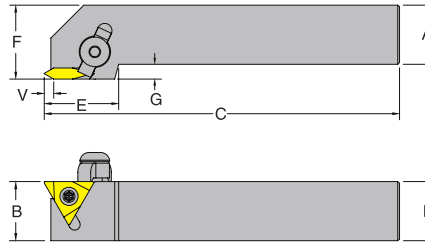
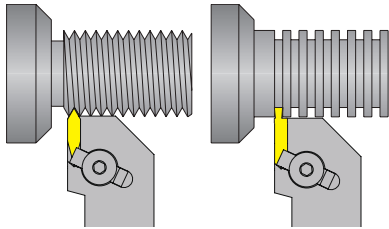

Inch Description	UPC No. 733101-		A	B	C	E	F	G	Max. GRV Depth V	TNMC Gage Insert	Insert Torx Screw	Torx key	Clamp	Clamp Clip	Clamp Screw
	R.H.	L.H.													
MTVOR/L08-3A-CN	58012	58013	0.500	0.500	4.000	1.000	0.625	0.125	0.150	322	GTS-1M	T-10	HC-9	CL-9	CS-96
MTVOR/L08-3B-CN	58016	58017	0.500	0.500	4.500	1.000	0.625	0.125	0.150						
MTVOR/L10-3B-CN	58020	58021	0.625	0.625	4.500	1.000	0.750	0.125	0.150						
MTVOR/L12-3B-CN	58024	58025	0.750	0.750	4.500	1.000	0.875	0.125	0.150						
MTVOR/L16-3D-CN	58028	58029	1.000	1.000	6.000	1.250	1.250	0.250	0.150						
MTVOR/L12-4B-CN	58032	58033	0.750	0.750	4.500	1.250	0.875	0.125	0.230	432	GTS-2	T-20	HC-12	CL-12	CS-126
MTVOR/L16-4D-CN	58036	58037	1.000	1.000	6.000	1.250	1.250	0.250	0.230						
MTVOR/L20-4D-CN	58040	58041	1.250	1.250	6.000	1.250	1.500	0.250	0.230						
MTVOR/L24-4E-CN	58044	58045*	1.500	1.500	7.000	1.375	1.750	0.250	0.230	543	GTS-3	T-20	HC-12	CL-12	CS-126
MTVOR/L16-5D-CN	58048	58049	1.000	1.000	6.000	1.500	1.250	0.250	0.292						
MTVOR/L20-5D-CN	58052	58053	1.250	1.250	6.000	1.500	1.500	0.250	0.292						

* Not standard stock item, call for lead time. For On Edge inserts see pages D-16 - E-19. For spare part see Page E-70.

STVO R/L Threading Toolholder- Style V - O.D. Threading and Shallow Grooving for triangle TNMC inserts

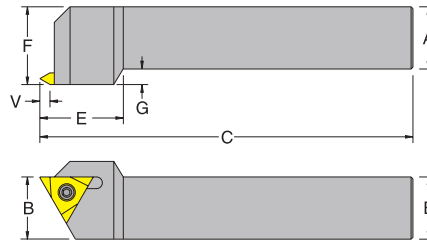
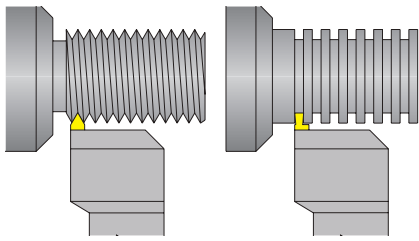

Right Hand Shown, Left Hand Opposite.

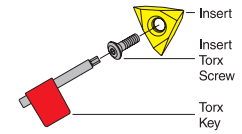

Inch Description	UPC No. 733101-		A	B	C	E	F	G	Max. GRV Depth V	TNMC Gage Insert	Insert Torx Screw	Torx key
	R.H.	L.H.										
STVOR/L08-3A	58070	58071	0.500	0.500	4.000	1.000	0.625	0.125	0.150	322	GTS-1M	T-10
STVOR/L10-3B	58074	58075	0.625	0.625	4.500	1.000	0.750	0.125	0.150			
STVOR/L12-3B	58078	58079	0.750	0.750	4.500	1.000	0.875	0.125	0.150			
STVOR/L16-3D	58082	58083	1.000	1.000	6.000	1.250	1.250	0.250	0.150	432	GTS-2	T-20
STVOR/L12-4B	58086	58087	0.750	0.750	4.500	1.250	0.875	0.125	0.230			
STVOR/L16-4D	58090	58091	1.000	1.000	6.000	1.250	1.250	0.250	0.230			
STVOR/L20-4D	58094	58095	1.250	1.250	6.000	1.250	1.500	0.250	0.230	543	GTS-3	T-20
STVOR/L24-4E	58098	58099	1.500	1.500	7.000	1.250	1.750	0.250	0.230			
STVOR/L16-5D	58102	58103	1.000	1.000	6.000	1.500	1.250	0.250	0.292			
STVOR/L20-5D	58106	58107	1.250	1.250	6.000	1.500	1.500	0.250	0.292	643	GTS-4	T-30
STVOR/L20-64D	58110	58111	1.250	1.250	6.000	1.750	1.500	0.250	0.360			
STVOR/L20-66D	58114	58115	1.250	1.250	6.000	1.750	1.500	0.250	0.360			

For On Edge inserts see pages D-16 - E-19. For spare part see Page E-70.

STHO R/L Threading Toolholder- Style H - Gang Toolholder for Shallow Grooving for I.D. Threading for triangle TNMC inserts

For Both Internal and External Operations

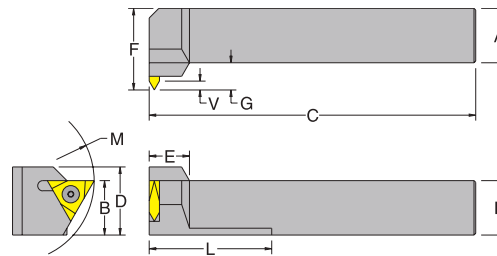
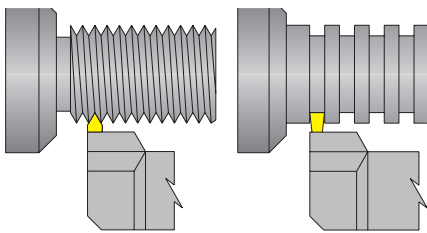

Right Hand Shown, Left Hand Opposite.

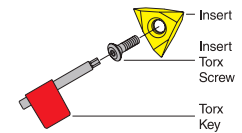

Inch Description	UPC No. 733101-		A	B	C	E	F	G	L	Min. Bore M	Max. GRV Depth V		TNMC Gage Insert	Insert Torx Screw	Torx key
	R.H.	L.H.									Min. I.D.	O.D.			
STHOR/L10-3B	58196	58197	0.625	0.625	4.500	0.875	1.000	0.375	-	2.0	0.100	0.125	322	GTS-1M	T-10
STHOR/L12-3B	58200	58201	0.750	0.750	4.500	0.875	1.125	0.375	1.500						
STHOR/L12-4B	58204	58205	0.750	0.750	4.500	0.875	1.250	0.500	-	3.0	0.125	0.194	432	GTS-2	T-20
STHOR/L16-4D	58208	58209*	1.000	1.000	6.000	0.875	1.500	0.500	2.000						
STHOR/L20-4D	-	58213	1.250	1.250	6.000	0.875	1.750	0.500	2.000						

* Not standard stock item, call for lead time. For On Edge inserts see pages D-16 - E-19. For spare part see Page E-70.

STZO R/L Threading Toolholder-Style Z - Reverse Hand Threading for triangle TNMC inserts

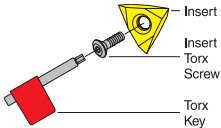
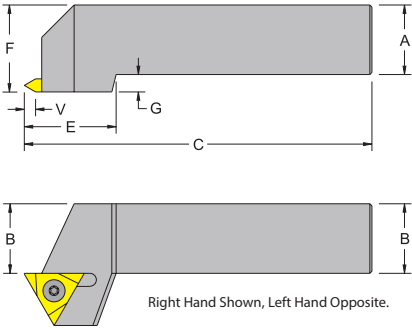
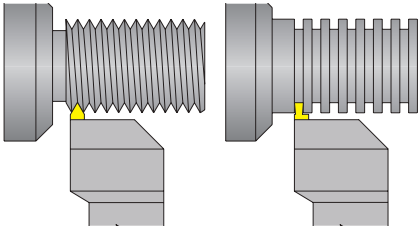

Inch Description	UPC No. 733101-		A	B	C	E	F	G	Max. GRV Depth V	TNMC Gage Insert	Insert Torx Screw	Torx key
	R.H.	L.H.										
STZOR/L12-3B	58230	-	0.750	0.750	4.500	1.000	1.000	0.250	0.150	322	GTS-1M	T-10
STZOR/L16-3D	58234	58235	1.000	1.000	6.000	1.000	1.250	0.250	0.150			
STZOR/L20-4D	58242	-	1.250	1.250	6.000	1.320	1.500	0.250	0.230	432	GTS-2	T-20
STZOR/L16-5D	58246	-	1.000	1.000	6.000	1.500	1.250	0.250	0.292	543	GTS-3	T-20

* Not standard stock item, call for lead time. For On Edge inserts see pages D-16 - E-19. For spare part see Page E-70.

S-MTHO-A R/L Threading Bar- Style H - I.D. Threading and Shallow Grooving for triangle TNMA inserts

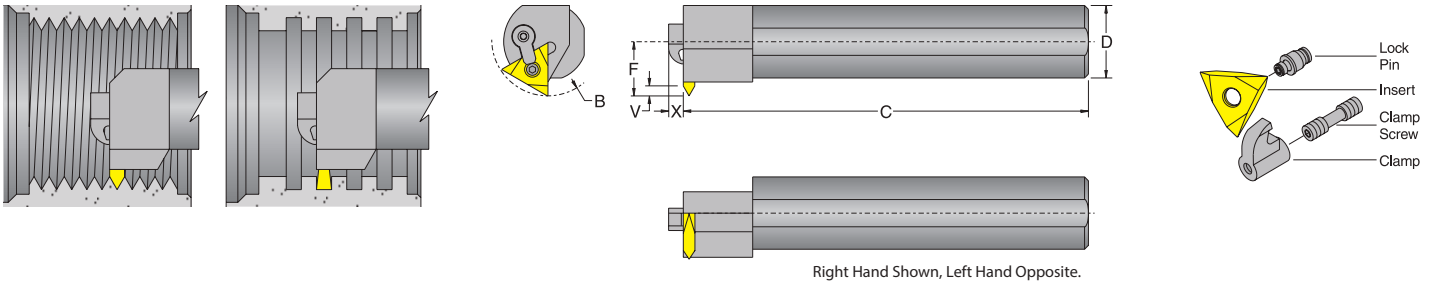

Inch Description	UPC No. 733101-		Min. Bore B	C	D	F	Max. GRV Depth V	X	TNMA Gage Insert	Lock Pin	Clamp	Clamp Screw
	R.H.	L.H.										
S16T-MTHOR/L-3-A	58346	58347	1.388	12.00	1.000	0.687	0.120	0.250	322	NL-33	CL-5	XNS-36
S20U-MTHOR/L-3-A	58350	58351	1.656	14.00	1.250	0.828	0.120	0.250				
S20U-MTHOR/L-4-A	58354	58355	1.812	14.00	1.250	0.875	0.190	0.250				
S24U-MTHOR/L-4-A	58358	58359	2.250	14.00	1.500	1.000	0.190	0.250	432	NL-44	CL-6	XNS-37
S32V-MTHOR/L-4-A	58362	58363	3.000	16.00	2.000	1.328	0.190	0.250				
S32V-MTHOR/L-5-A	58366	58367	3.500	16.00	2.000	1.375	0.250	0.250	543	NL-56	CL-6	XNS-37
S40V-MTHOR/L-5-A	58370	58371	3.750	16.00	2.500	1.687	0.250	0.250				
S48Y-MTHOR/L-5-A	58374	58375	4.000	18.00	3.000	1.891	0.250	0.250				
S40V-MTHOR/L-66-A	58378	58379	4.000	16.00	2.500	1.750	0.312	0.312	663	NL-66L	CL-12	XNS-59
S48Y-MTHOR/L-66-A	-	58383	4.500	18.00	3.000	2.000	0.312	0.312				

For On Edge inserts see pages D-16 - D-19. For spare part see page D-70.

S-MTHO-C R/L Threading Bar- Style H - I.D. Threading and Shallow Grooving for triangle TNMC inserts

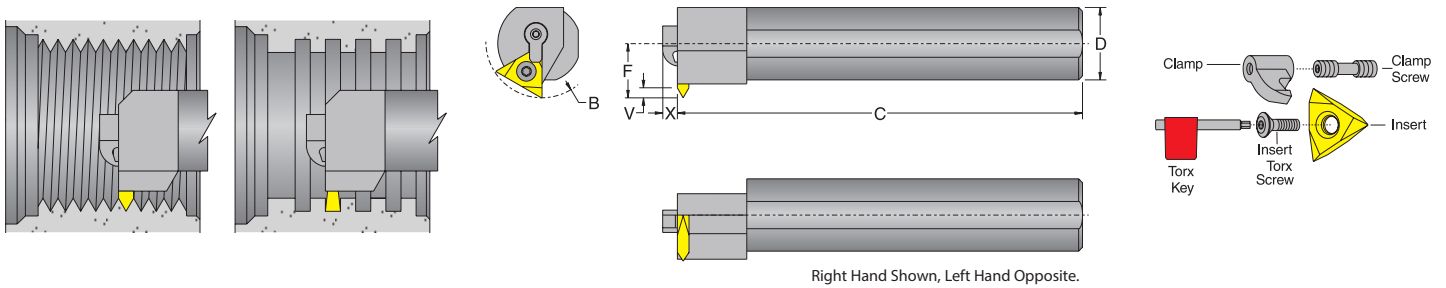

Inch Description	UPC No. 733101-		Min. Bore B	C	D	F	Max. GRV Depth V	X	TNMC Gage Insert	Insert Torx Screw	Torx Key	Clamp	Clamp Screw
	R.H.	L.H.											
S16T-MTHOR/L-3-C	58300	-	1.388	12.00	1.000	0.687	0.120	0.250	322	GTS-1M	T-10	CL-19	XNS-36
S20U-MTHOR/L-3-C	58304	-	1.656	14.00	1.250	0.828	0.120	0.250					
S20U-MTHOR/L-4-C	58308	58309	1.812	14.00	1.250	0.875	0.190	0.250	432	GTS-2	T-20	CL-7	XNS-36
S24U-MTHOR/L-4-C	58312	58313	2.250	14.00	1.500	1.000	0.190	0.250					
S32V-MTHOR/L-4-C	58316	58317	3.000	16.00	2.000	1.328	0.190	0.250					
S32V-MTHOR/L-5-C	58320	58321	3.500	16.00	2.000	1.375	0.250	0.250	543	GTS-3	T-20	CL-20	XNS-47
S40V-MTHOR/L-5-C	58324	-	3.750	16.00	2.500	1.687	0.250	0.250					
S40V-MTHOR/L-66-C	58332	58333	4.000	16.00	2.500	1.750	0.312	0.312	663	GTS-4	T-30	CL-12	XNS-59

For On Edge inserts see pages D-16 - E-19. For spare part see Page E-70.

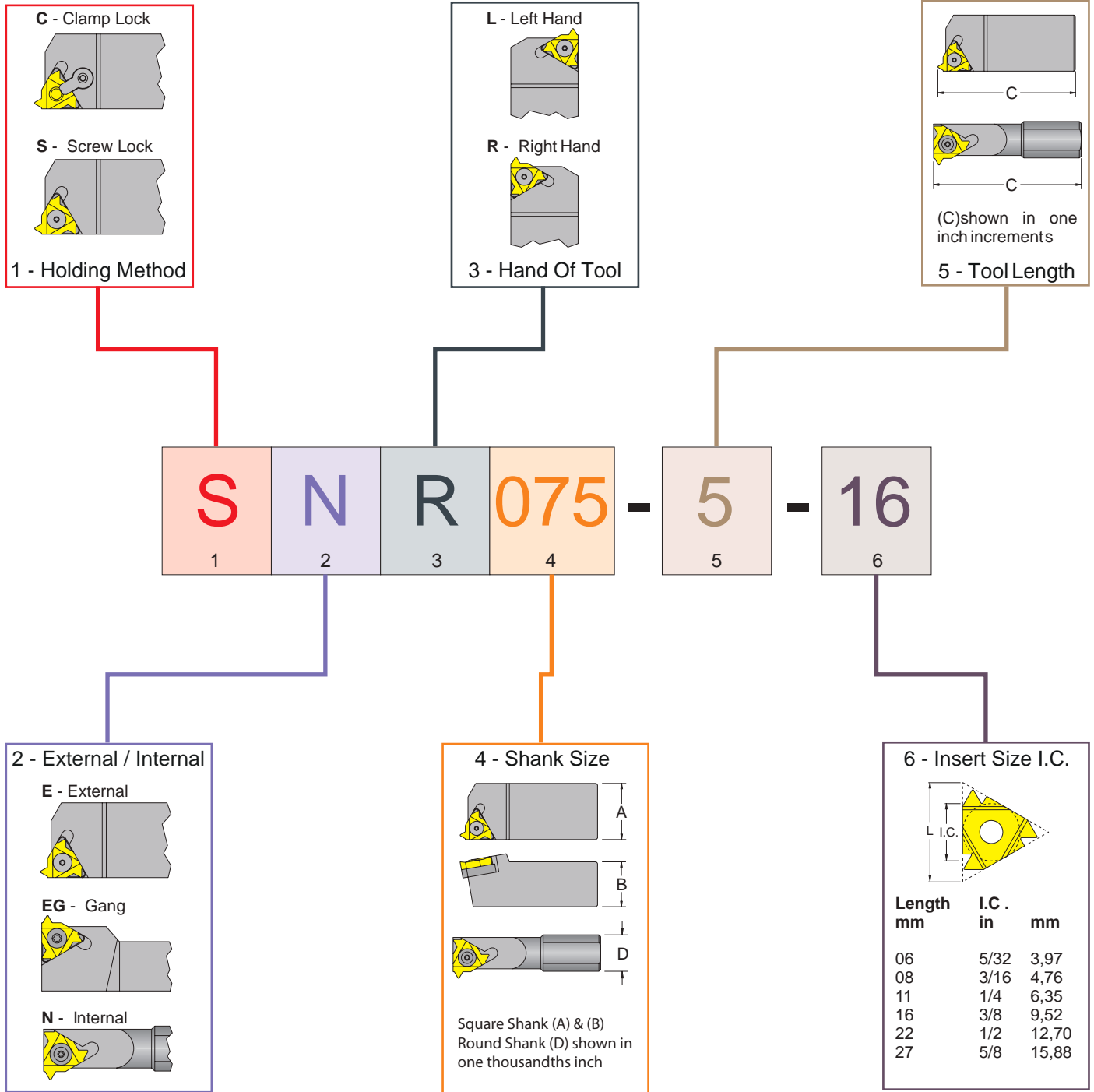

Laydown Threading Toolholders

SE R/L Threading Toolholder- Style E- Laydown for LAYDOWN inserts

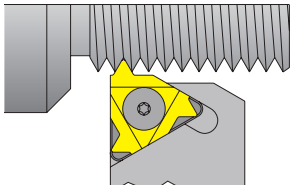

- Geometry of the insert seating:
Helix angle 1-1/2°

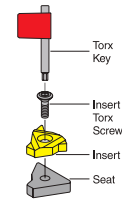
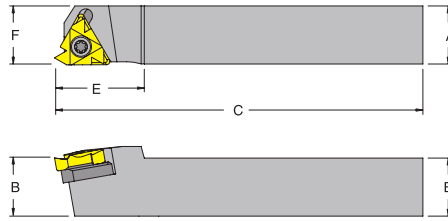

Inch Description	UPC No. 733101- R.H.	L.H.	A	B	C	E	F	Laydown Gage Insert	Shim Seat	Insert Torx Screw	Torx Key
SER/L037-3-11	58420	-	0.375	0.375	3.000	0.875	0.375	11-A60	-	TS-25.4-6M2	T-8
SER/L062-4-16	58428	58429	0.625	0.625	4.000	1.000	0.625	16-G60	GXE-16	TS-35.6-14M1	T-10
SER/L075-5-16	58432	-	0.750	0.750	5.000	1.000	0.750				
SER/L100-5-16	58436	-	1.000	1.000	5.000	1.000	1.000	22-N60	NXE-22	TS-45.75-15M1	T-20
SER/L100-6-22	58440*	-	1.000	1.000	6.000	1.000	1.000				
SER/L125-6-22	58444	58445	1.250	1.250	6.000	1.000	1.250	27-Q60	VXE-27	TS-5.8-22M1	T-25
SER/L100-6-27	58448	58449	1.000	1.000	6.000	1.250	1.000				
SER/L125-6-27	58452	58453	1.250	1.250	6.000	1.250	1.250				

* Not standard stock item, call for lead time. For Laydown inserts see pages D-24 - E-29. For spare part see Page E-70. For Shim Seats see Page E-22.

SE Gang R/L Threading Toolholder- Style EG - Gang Toolholder for Gang Toolposts for LAYDOWN inserts

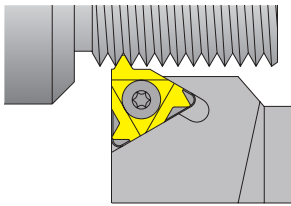

- Geometry of the insert seating:
Helix angle 1-1/2°

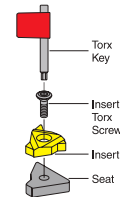
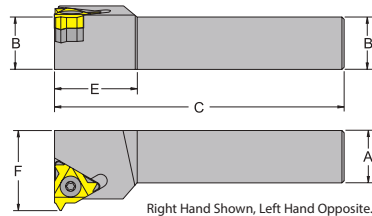

Inch Description	UPC No. 733101- R.H.	L.H.	A	B	C	E	F	Laydown Gage Insert	Shim Seat	Insert Torx crew	Torx Key
SEGR/L037-4-11	58466	58467	0.375	0.375	4.000	0.875	0.625	11-A60	-	TS-25.4-6M2	T-8
SEGR/L050-5-16	58470	-	0.500	0.500	5.000	1.000	0.750	16-G60	GXE-16	TS-35.6-14M1	T-10
SEGR/L062-5-16	58474	58475	0.625	0.625	5.000	1.000	0.875				
SEGR/L075-5-16	58478	58479	0.750	0.750	5.000	1.000	1.000				

For Laydown inserts see pages D-24 - E-29. For spare part see Page E-70. For Shim Seats see Page E-22.

SE R/L Qualified Threading Toolholder- Style - Laydown Offset Head for LAYDOWN inserts

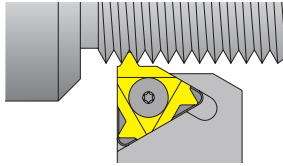

• Geometry of the insert seating:
Helix angle 1-1/2°

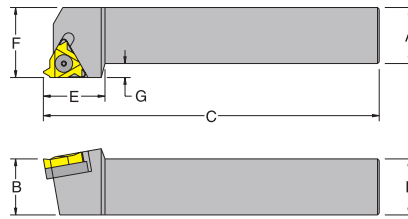

Right Hand Shown, Left Hand Opposite.

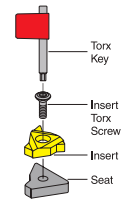

Inch Description	UPC No. 733101-		A	B	C	E	F	G	Laydown Gage Insert	Shim Seat	Insert Torx crew	Torx Key
	R.H.	L.H.										
SER/L050-4-11Q	58488	58489	0.500	0.500	4.000	1.000	0.625	0.125	11-A60	-	TS-25.4-6M2	T-8
SER/L075-5-16Q	58492	58493	0.750	0.750	5.000	1.000	1.000	0.250	16-G60	GXE-16	TS-35.6-14M1	T-10
SER/L100-6-16Q	58496	58497	1.000	1.000	6.000	1.000	1.250	0.250				
SER/L125-6-16Q	58500	-	1.250	1.250	6.000	1.000	1.500	0.250	22-N60	NXE-22	TS-45.75-15M1	T-20
SER/L100-6-22Q	58504	58505	1.000	1.000	6.000	1.000	1.250	0.250				
SER/L125-6-22Q	58508	-	1.250	1.250	6.000	1.000	1.500	0.250	27-Q60	VXE-27	TS-5.8-22M1	T-25
SER/L125-6-27Q	58511*	58512	1.250	1.250	6.000	1.250	1.500	0.250				

* Not standard stock item, call for lead time. For Laydown inserts see pages D-24 - E-29. For spare part see Page E-70. For Shim Seats see Page E-22.

SE R/L Qualified Threading Toolholder- Style - Drop Head for LAYDOWN inserts

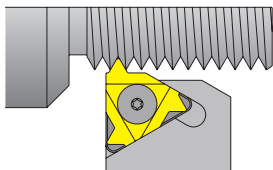

• Geometry of the insert seating:
Helix angle 1-1/2°

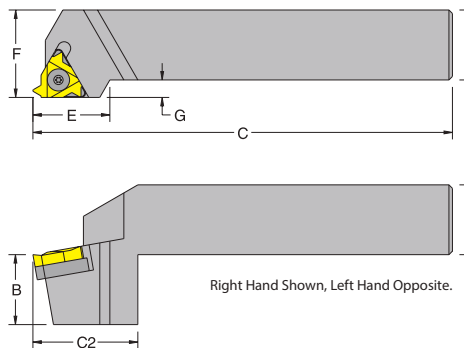

Right Hand Shown, Left Hand Opposite.

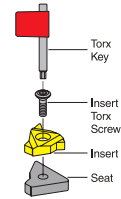

Inch Description	UPC No. 733101-		A	B	C	C2	E	F	G	Laydown Gage Insert	Shim Seat	Insert Torx crew	Torx Key
	R.H.	L.H.											
SER/L075-6-16CQ	-	58523	0.750	0.750	6.000	1.500	0.900	1.000	0.250	16-G60	GXE-16	TS-35.6-14M1	T-10
SER/L100-6-16CQ	58526	58527	1.000	1.000	6.000	1.500	0.900	1.250	0.250				
SER/L125-6-16CQ	58530	-	1.250	1.250	6.000	1.500	0.900	1.500	0.250				

For Laydown inserts see pages D-24 - E-29. For spare part see Page E-70. For Shim Seats see Page E-22.

Laydown Threading Toolholders

SN R/L Threading Bar- Style - Internal Small Shank Laydown Bar for LAYDOWN inserts

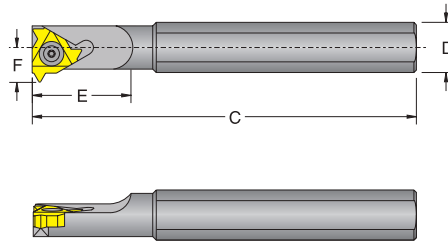
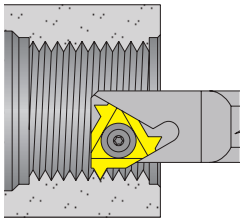

Right Hand Shown, Left Hand Opposite.

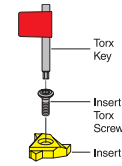

- Minimum threading dia. .500"
- Geometry of the insert seating:
Helix angle 1-1/2°

Inch Description	UPC No. 733101-		Min. Bore B	C	D	E	F	Laydown Gage Insert	Insert Torx crew	Torx Key
	R.H.	L.H.								
SNR/L037-40-11	58600	58601	0.500	4.000	0.375	-	0.250	11-A60	TS-25.4-6M2	T-8
SNR/L050-55-11	58604	58605	0.600	5.500	0.500	1.250	0.315			
SNR/L062-60-16	58608	58609	0.750	6.000	0.625	1.500	0.406	16-G60	TS-35.6-9M1	T-10
SNR/L075-70-16	58612	58613*	0.950	7.000	0.750	2.000	0.492			
SNR/L100-80-16	58616	58617	1.150	8.000	1.000	2.500	0.650			
SNR/L075-70-22	58620	58621*	0.900	7.000	0.750	2.000	0.492	22-N60	TS-45.75-15M1	T-20
SNR/L100-80-22	58624	58625	1.500	8.000	1.000	2.500	0.840			

* Not standard stock item, call for lead time. For Laydown inserts see pages D-24 - E-29. For spare part see Page E-70. For Shim Seats see Page E-22.

SN R/L Threading Bar- Style - Internal Laydown Bar for LAYDOWN inserts

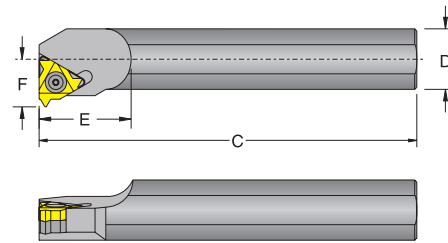
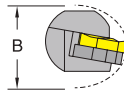
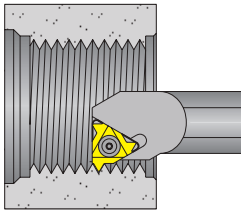

Right Hand Shown, Left Hand Opposite.

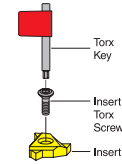

- Minimum threading dia. .950"
- Geometry of the insert seating:
Helix angle 1-1/2°

Inch Description	UPC No. 733101-		Min. Bore B	C	D	E	F	Laydown Gage Insert	Shim Seat	Insert Torx crew	Torx Key
	R.H.	L.H.									
SNR/L075-07-16	58636	58637*	0.950	7.00	0.750	2.000	0.520	16-G60	GXE-16	TS-35.6-14M1	T-10
SNR/L100-08-16	58640	58641*	1.150	8.00	1.000	2.500	0.650				
SNR/L125-10-16	58644	58645	1.400	10.00	1.250	2.500	0.780				
SNR/L150-12-16	58648	58649*	1.700	12.00	1.500	2.500	0.900				
SNR/L175-14-16	58652	58653	2.000	14.00	1.750	2.500	1.030				
SNR/L200-14-16	58656	58657	2.200	14.00	2.000	2.500	1.210				
SNR/L125-10-22	58664	58665	1.500	10.00	1.250	2.500	0.840	22-N60	NXE-22	TS-45.75-15M1	T-20
SNR/L150-12-22	58668	-	1.800	12.00	1.500	2.500	0.970				
SNR/L175-14-22	58672*	-	2.100	14.00	1.750	2.500	1.090				
SNR/L200-14-22	58676	58677	2.300	14.00	2.000	2.500	1.210				
SNR/L250-16-22	58680	58681	2.800	16.00	2.500	2.500	1.460	27-Q60	VXE-27	TS-5.8-22M1	T-25
SNR/L150-12-27	58684	58685	1.900	12.00	1.500	2.500	1.020				
SNR/L175-14-27	-	58689	2.200	14.00	1.750	2.500	1.150				
SNR/L250-16-27	58692	-	2.900	16.00	2.500	3.000	1.520				

* Not standard stock item, call for lead time. For Laydown inserts see pages D-24 - E-29. For spare part see Page E-70. For Shim Seats see Page E-22.

Miniature Laydown Threading Bars Take Over Where Taps Leave Off

- **Small Hole Capacity** - to a minimum of .226 / 6mm.
- **Better finish** - Miniature threading bars result in thread geometry and closer tolerances.
- **Greater productivity through better tool utilization** - For CNC turning centers and manual lathes and a wide range of workpiece materials. Also, creates less machine load than taps.
- **Fully threads a blind hole** - Threads deeper than a tap and never gets stuck.

TYPICAL CNC APPLICATION

- **One Set-up**
- **Two Threads**

Two threads, NPT 1/8"-27, in one operation on a CNC lathe with bar feeder. The whole part is produced in one set-up, therefore, increasing productivity.

Carbide shank threading bars are used when chatter and deflection is expected due to long overhang in deep small bores.

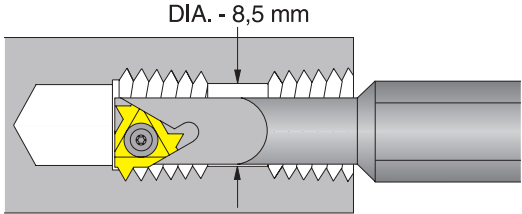

The Miniature and Ultra Miniature Threading

bars are replacing taps with many advantages. The small inserts and the low speed coated grades available make threading to a minimum diameter of .236 in or 6 mm possible.

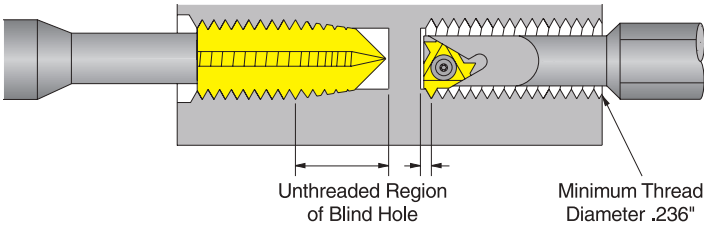

06IR-A60-DVP656-

All these taps, and more, can be replaced cost effectively with only this one insert.

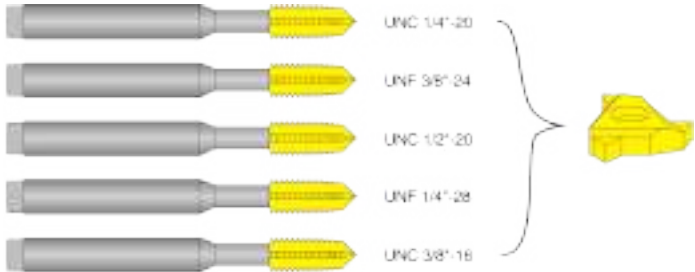

SN R/L Threading Bar- Style - Internal Laydown Miniature Threading Bar for LAYDOWN inserts

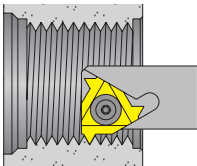

- Alloy steel threading bar
- Carbide threading bar
- Geometry of the insert seating: Helix angle 1-1/2°

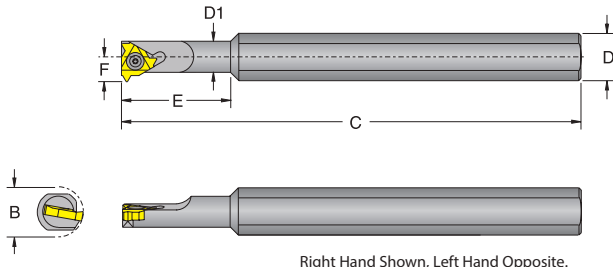

Right Hand Shown, Left Hand Opposite.

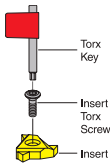

Inch Description	UPC No. 733101-		Min.Bore B	C	D	D1	E	F	Laydown Gage Insert	Insert Torx crew	Torx Key
	R.H.	L.H.									
SNR/L0265-K08	58578	58579	0.307	5.000	0.625	0.265	0.710	0.154	08-A60	TS-08	T-6

For Laydown inserts see pages 31-36. For spare part see page 79.

Square Shanks

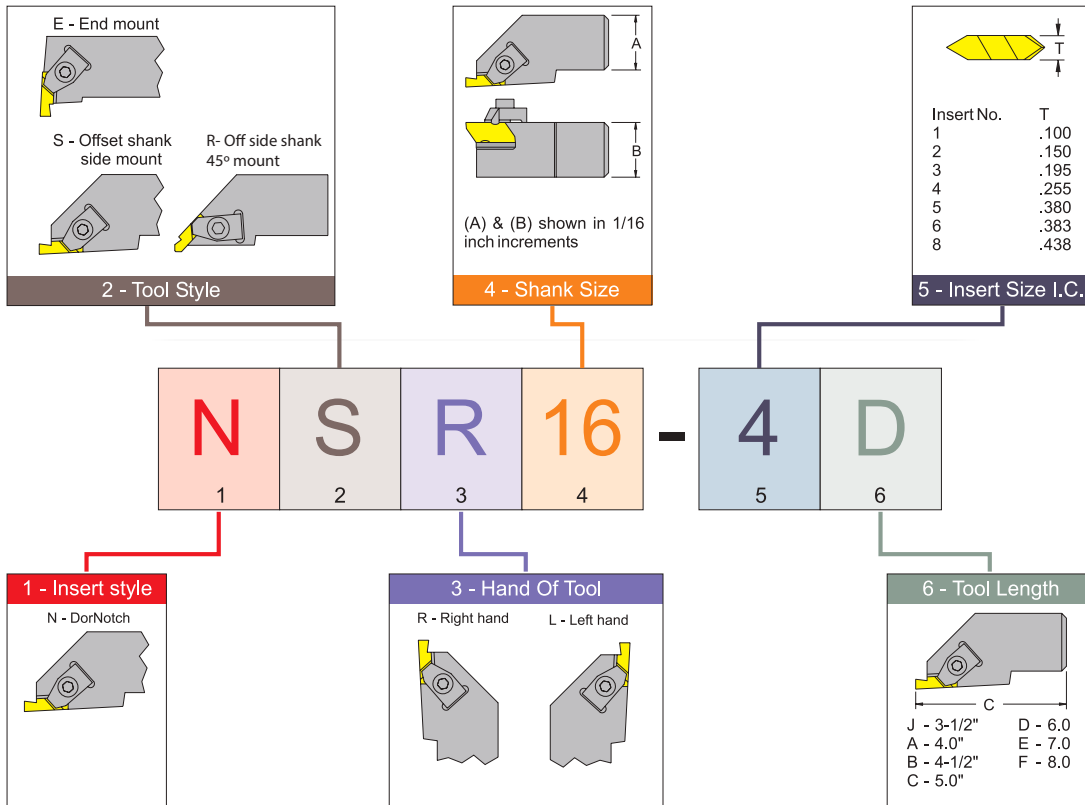

Boring Bars

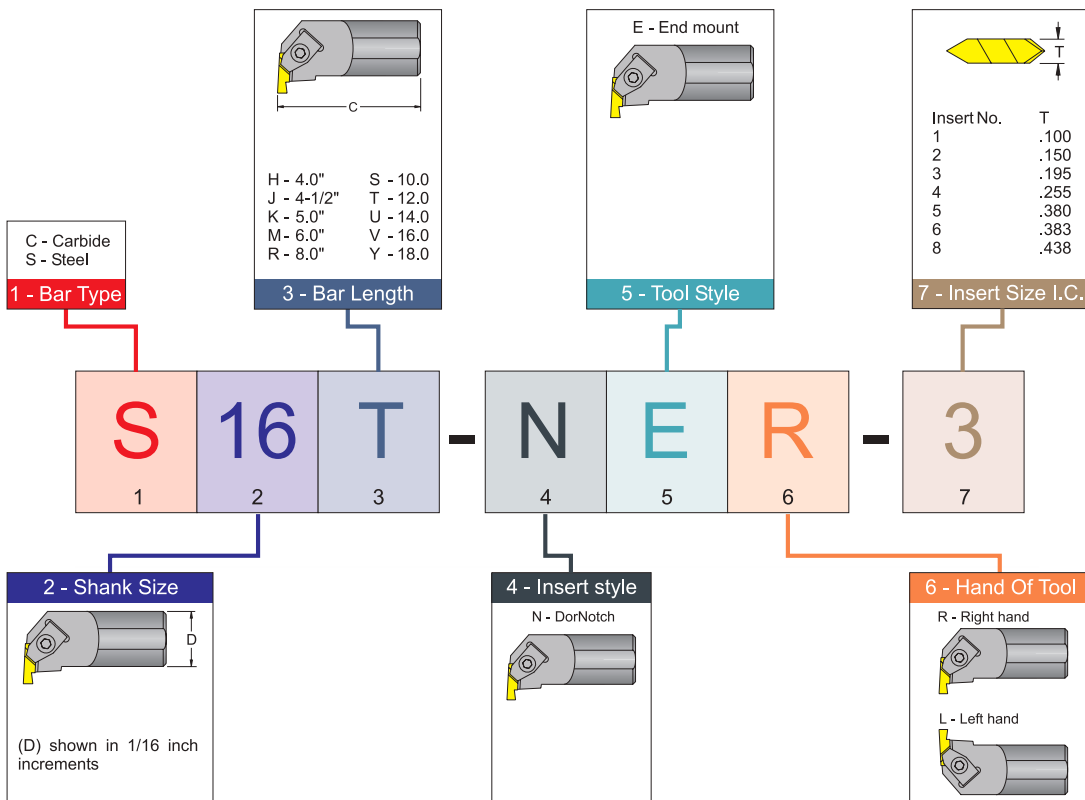

NS R/L Threading & Grooving Toolholder- Style - External DorNotch Toolholder for threading and grooving DorNotch inserts

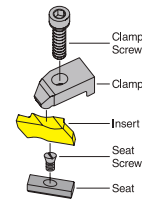
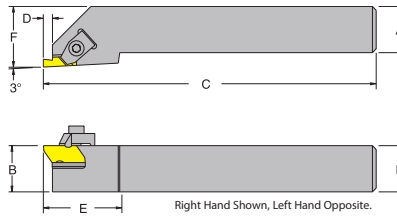
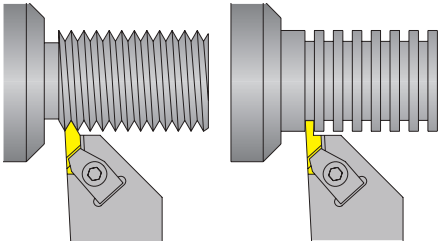

Inch Description	UPC No. 733101-		A	B	C	D	E	F	DorNotch Gage Insert	Seat	Seat Screw	Clamp	Clamp Screw
	R.H.	L.H.											
NSR/L06-2	58770	58771	0.375	0.375	2.500	0.138	0.750	0.562	NG-2R* NG-2L**	-	-	CM-74* CM-75**	S-310
NSR/L08-2J	58774	58775	0.500	0.500	3.500	0.138	0.750	0.750					
NSR/L10-2B	58778	58779	0.625	0.625	4.500	0.138	0.750	0.875					
NSR/L12-2B	58782	58783	0.750	0.750	4.500	0.138	0.750	1.000					
NSR/L16-2C	58786	58787	1.000	1.000	5.000	0.138	0.750	1.250					
NSR/L12-3A	58790	58791	0.750	0.750	4.000	0.210	1.250	1.000	NG-3R* NG-3L**	-	-	CM-72* CM-73**	S-412
NSR/L12-3B	58794	58795	0.750	0.750	4.500	0.210	1.250	1.000					
NSR/L16-3C	58798	58799	1.000	1.000	5.000	0.210	1.250	1.250					
NSR/L16-3D	58802	58803	1.000	1.000	6.000	0.210	1.250	1.250					
NSR/L20-3D	58806	58807	1.250	1.250	6.000	0.210	1.250	1.500					
NSR/L16-4C	58810	58811	1.000	1.000	5.000	0.294	1.380	1.250	NG-4R* NG-4L**	SM-420	SL-344-X	CM-72* CM-73**	S-412
NSR/L16-4D	58814	58815	1.000	1.000	6.000	0.294	1.380	1.250					
NSR/L20-4C	-	58819	1.250	1.250	5.000	0.294	1.380	1.500					
NSR/L20-4D	58822	58823	1.250	1.250	6.000	0.294	1.380	1.500					
NSR/L24-4D	-	58827	1.500	1.500	6.000	0.294	1.380	1.750					

For DorNotch inserts see pages D-32 - E-35. For spare part see Page E-70. *For right hand tools. ** For left hand tools.

NE R/L Threading & Grooving Toolholder- Style - Gang External DorNotch Toolholder for threading and grooving DorNotch inserts

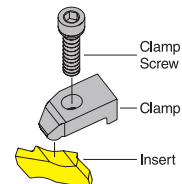
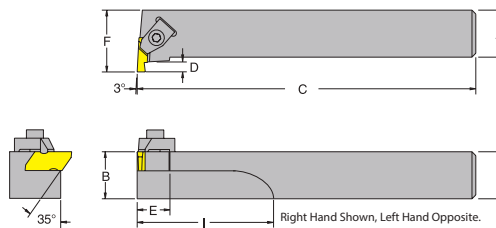
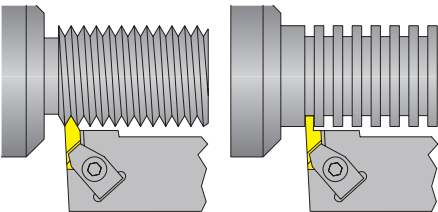

Inch Description	UPC No. 733101-		A	B	C	D	E	F	I	DorNotch Gage Insert	Clamp	Clamp Screw
	R.H.	L.H.										
NER/L06-2	-	58901	0.375	0.375	2.500	0.138	0.500	0.750	1.000	NG-2L* NG-2R**	CM-74* CM-75**	S-310
NER/L08-2J	58904	58905	0.500	0.500	3.500	0.138	0.500	0.750	1.000			
NER/L12-2B	58912	58913	0.750	0.750	4.500	0.138	0.500	1.000	1.000			
NER/L12-3B	58916	-	0.750	0.750	4.500	0.210	0.750	1.125	2.000	NG-3L* NG-3R**	CM-72* CM-73**	S-412
NER/L16-3D	58920	58921	1.000	1.000	6.000	0.210	0.750	1.250	2.000			
NER/L20-3D	58924	-	1.250	1.250	6.000	0.210	0.750	1.500	2.000			
NER/L16-4D	58928	58929	1.000	1.000	6.000	0.294	0.750	1.375	2.000	NG-4L* NG-4R**	CM-72* CM-73**	S-412
NER/L20-4D	58932	58933	1.250	1.250	6.000	0.294	0.750	1.625	2.000			

For DorNotch inserts see pages D-32 - E-35. For spare part see Page E-70. *For right hand tools. ** For left hand tools.

DorNotch Threading Toolholder & Bar

NR R/L Grooving Gang Toolholder- Style - Corner Grooving External DorNotch Toolholder for grooving DorNotch inserts

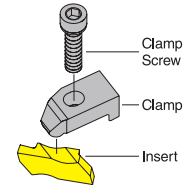
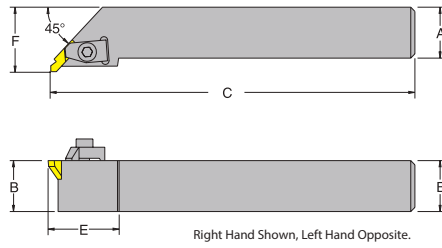
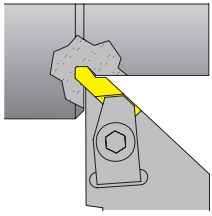

Inch Description	UPC No. 733101-		A	B	C	E	F	DorNotch Gage Insert	Clamp	Clamp Screw
	R.H.	L.H.								
NRR/L12-3B	58942	-	0.750	0.750	4.500	1.250	1.000	*NG-3L **NG-3R	*CM-73 **CM-72	S-412
NRR/L16-3C	-	58945	1.000	1.000	5.000	1.250	1.250			
NRR/L16-3D	58946	-	1.000	1.000	6.000	1.250	1.250			
NRR/L20-3D	58948	58949	1.250	1.250	6.000	1.375	1.500			
NRR/L24-3D	58950	58951	1.500	1.500	6.000	1.375	2.000			

For DorNotch inserts see pages D-32 - E-35. For spare part see Page E-70. *For right hand tools. ** For left hand tools.

S-NE R/L Threading & Grooving Bar - Style - Internal DorNotch Bar for threading and grooving DorNotch inserts

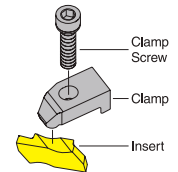
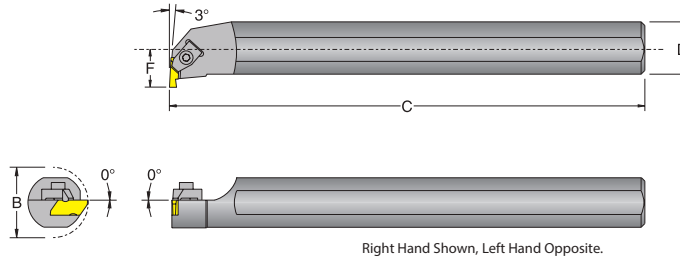
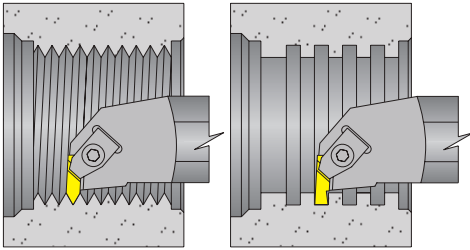

Inch Description	UPC No. 733101-		Min. Bore B	C	D	F	DorNotch Gage Insert	Clamp	Clamp Screw
	R.H.	L.H.							
S10S-NER/L-2	58970	58971	1.000	10.00	0.625	0.500	*NG-2L **NG-2R	*CM-75 **CM-74	S-310
S12S-NER/L-2	58974	58975	1.125	10.00	0.750	0.562			
S16T-NER/L-3	58978	58979	1.375	12.00	1.000	0.688	*NG-3L **NG-3R	*CM-73 **CM-72	S-412
S20U-NER/L-3	58982	58983	1.750	14.00	1.250	0.875			
S24U-NER/L-3	58986	58987	2.000	14.00	1.500	1.000			
S28U-NER/L-3	58990	58991	2.250	14.00	1.750	1.125			
S28U-NER/L-4	58994	58995	2.500	14.00	1.750	1.250			
S32V-NER/L-4	58998	58999	2.750	16.00	2.000	1.375	*NG-4L **NG-4R	*CM-73 **CM-72	S-412

For DorNotch inserts see pages D-32 - E-35. For spare part see Page E-70. *For right hand tools. ** For left hand tools.

MTVO-A - API Threading Toolholder- Style V - O.D. Threading and Shallow Grooving for triangle TNMA inserts

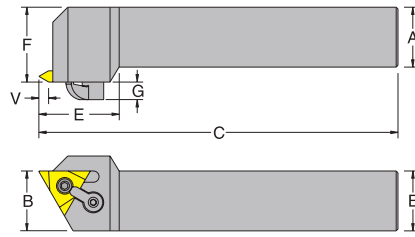
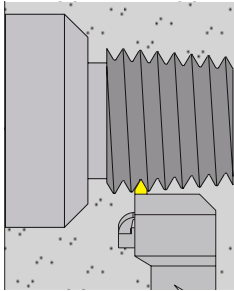

Right Hand Shown, Left Hand Opposite.

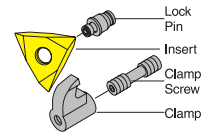

Inch Description	UPC No. 733101-		A	B	C	E	F	G	Max. GRV Depth V	TNMA	Lock	Clamp	Clamp
	R.H.									Gage insert	Pin		Screw
MTVOR16-5D-A	58158		1.000	1.000	6.000	1.500	1.250	0.250	0.292	543	NL-56	CL-6	XNS-36
MTVOR20-5D-A	58162		1.250	1.250	6.000	1.500	1.500	0.250	0.292				

For API On Edge inserts see pages D-38 - E-39. For spare part see Page E-70. For API Jet-Stream™ Thru Coolant Threading Toolholders and Bars see Pages E-52-E-57

MTVO-C - API Threading Toolholder- Style V - O.D. Threading and Shallow Grooving for triangle TNMC inserts

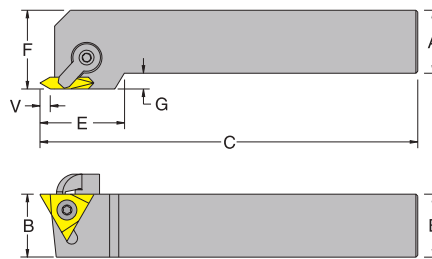
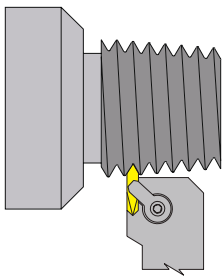

Right Hand Shown, Left Hand Opposite.

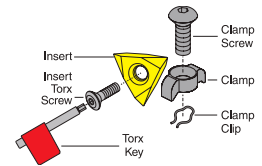

Inch Description	UPC No. 733101-		A	B	C	E	F	G	Max. GRV Depth V	TNMC	Insert	Torx	Clamp	Clamp	Clamp
	R.H.									Gage Insert	Torx Screw	key		Clip	Screw
MTVOR16-5D-C	58048		1.000	1.000	6.000	1.500	1.250	0.292	0.292	543	GTS-3	T-20	HC-12	CLP-12	CS-126
MTVOR20-5D-C	58052		1.250	1.250	6.000	1.500	1.500	0.292	0.292						

* Not standard stock item, call for lead time. For API On Edge inserts see pages D-38 - E-39. For spare part see Page E-70. For API Jet-Stream™ Thru Coolant Threading Toolholders and Bars see Pages E-52-E-57

S-MTHO-A - API Threading Bar- Style H - I.D. Threading and Shallow Grooving for triangle TNMA inserts

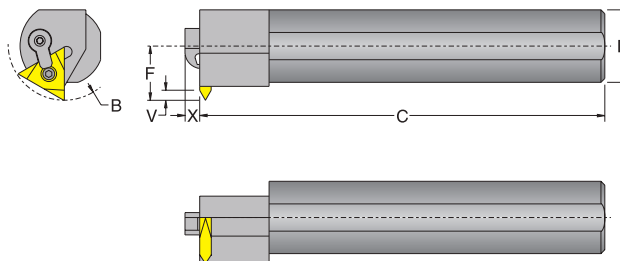
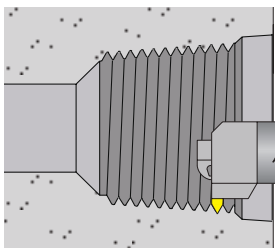

Right Hand Shown, Left Hand Opposite.

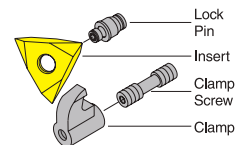

Inch Description	UPC No. 733101-		Min. Bore B	C	D	F	Max. GRV Depth V	X	TNMA	Lock	Clamp	Clamp
	R.H.								Gage Insert	Pin		Screw
S32V-MTHOR-5-A	58366		3.500	16.00	2.000	1.375	0.250	0.250	543	NL-56	CL-6	XNS-37
S40V-MTHOR-5-A	58370		3.750	16.00	2.500	1.687	0.250	0.250				

For API On Edge inserts see pages D-38 - E-39. For spare part see Page E-70. For API Jet-Stream™ Thru Coolant Threading Toolholders and Bars see Pages E-52-E-57

API Laydown Threading Toolholders

SE - API Threading Toolholder- Style - Laydown for LAYDOWN inserts

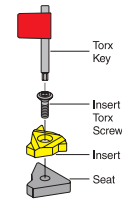
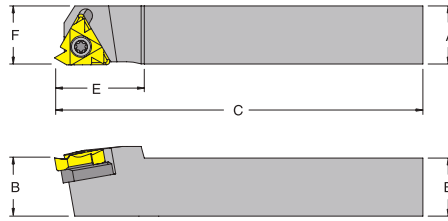
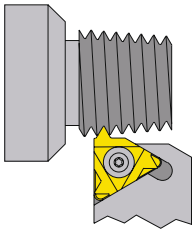

• Geometry of the insert seating:
Helix angle 1-1/2°

Inch Description	UPC No. 733101-R.H.	A	B	C	E	F	Laydown Gage Insert	Shim Seat	Insert Torx crew	Torx Key
SER100-5-16	58436	1.000	1.000	5.000	1.100	1.000	16-G60	GXE-16	TS-35.6-14M1	T-10
SER100-6-22	*58440	1.000	1.000	6.000	1.100	1.000	22-N60	NXE-22	TS-45.75-15M1	T-20

* Not standard stock item, call for lead time. For API Laydown inserts see pages D-40 - E-44. For spare part see Page E-70. For Shim Seats see Page E-22.
For API Jet-Stream™ Thru Coolant Threading Toolholders and Bars see Pages E-52-E-57

SE - API Threading Toolholder- Style External API Laydown Toolholder for LAYDOWN inserts

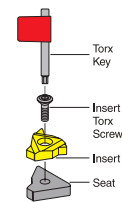
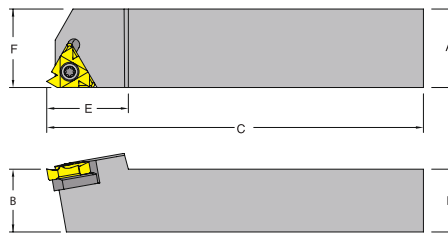
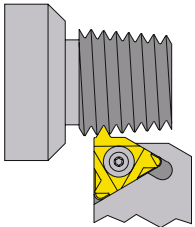

• Geometry of the insert seating:
Helix angle 1-1/2°

Inch Description	UPC No. 733101-R.H.	A	B	C	E	F	Laydown Gage Insert	Shim Seat	Insert Torx crew	Torx Key
SER100-T22API	*58720	1.250	1.000	6.00	1.300	1.250	22-N60	NXE-22	TS-45.75-15M1	T-20

* Not standard stock item, call for lead time. For API Laydown inserts see pages D-40 - E-44. For spare part see Page E-70. For Shim Seats see Page E-22.
For API Jet-Stream™ Thru Coolant Threading Toolholders and Bars see Pages E-52-E-57

NS - API Threading & Grooving Toolholder- Style - External DorNotch Toolholder for threading and grooving DorNotch inserts

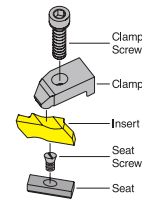
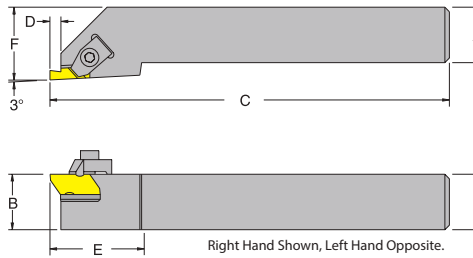
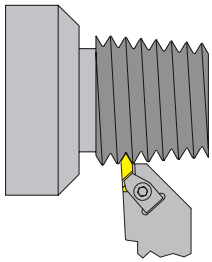

Inch Description	UPC No. 733101-R.H.	A	B	C	D	E	F	DorNotch Gage Insert	Seat	Seat Screw	Clamp	Clamp Screw
NSR/L16-3D	58802	1.000	1.000	6.000	0.210	1.250	1.250	*NG-3R	-	-	*CM-72	S-412
NSR/L20-3D	58806	1.250	1.250	6.000	0.210	1.250	1.500					
NSR/L16-4D	58814	1.000	1.000	6.000	0.294	1.380	1.250	*NG-4R	SM-420	SL-344	*CM-72	S-412
NSR/L20-4D	58822	1.250	1.250	6.000	0.294	1.380	1.500	*NG-4R	SM-420	SL-344	*CM-72	S-412

For API DorNotch inserts see pages D-46. For spare part see Page E-70. *For right hand tools. For API Jet-Stream™ Thru Coolant Threading Toolholders and Bars see Pages E-52-E-57

S-NE - API Threading & Grooving Bar - Style - Internal DorNotch Bar for threading and grooving DorNotch inserts

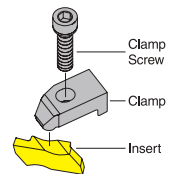
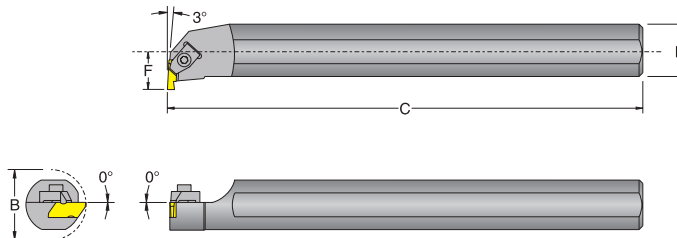
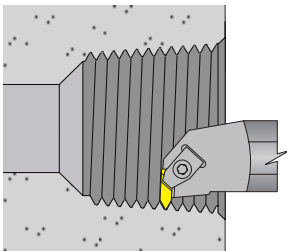

Inch Description	UPC No. 733101-R.H.	Min. Bore B	C	E	F	DorNotch Gage Insert	Clamp	Clamp Screw
S24U-NER/L-3	58986	2.000	14.00	1.500	1.000	*NG-3L	*CM-73	S-412
S32V-NER/L-4	58998	2.750	16.00	2.000	1.375	*NG-4L	*CM-73	S-412

For API DorNotch inserts see pages D-46 . For spare part see Page E-70. *For right hand tools. For API Jet-Stream™ Thru Coolant Threading Toolholders and Bars see Pages E-52-E-57

L- API & Chaser Threading Toolholders

MTVNR- L - API Threading Toolholder

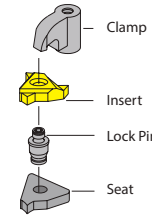
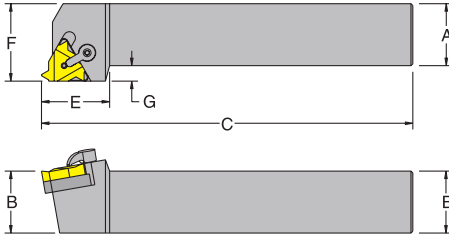
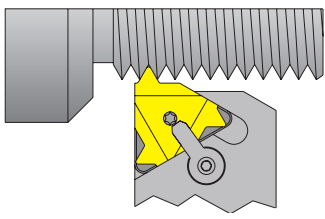

Inch Description	UPC No. 733101- R.H.	A	B	C	E	F	Laydown Gage Insert	Seat	Lock Pin	Clamp	Clamp Screw
MTVNR-20-L53D	58293	1.25	1.25	6.00	1.53	1.500	L53	LS53	NL58	CL12	XNS510

For L-API inserts see pages D-47 - E-49. For spare part see Page E-70. For API Jet-Stream™ Thru Coolant Threading Toolholders and Bars see Pages E-52-E-57

S_MTVNR- L - API Threading Bar

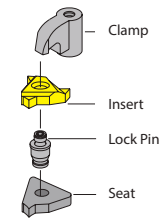
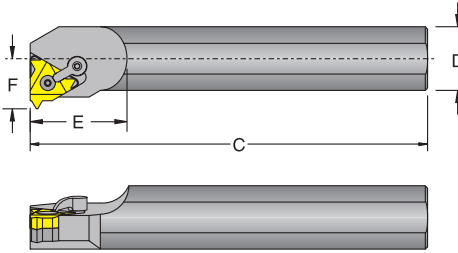
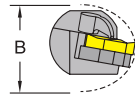
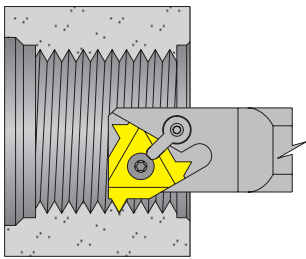

Inch Description	UPC No. 733101- R.H.	Min. Bore B	C	D	E	F	L - API Gage Insert	Seat	Lock Pin	Clamp	Clamp Screw
S32U MTVNR-L43	58287	2.000	14.00	2.00	3.75	1.00	L43	LS43	NL46	CL9	XNS59
S32U MTVNR-L53	58389	2.000	14.00	2.00	3.75	1.00	NL-57	-	NL56	CL12	XNS510

For L-API inserts see pages D-47 - E-49. For spare part see Page E-70. For API Jet-Stream™ Thru Coolant Threading Toolholders and Bars see Pages E-52-E-57

CLVOR - API Chaser Threading Toolholder

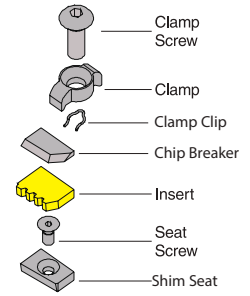
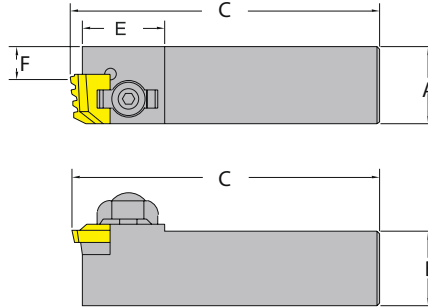
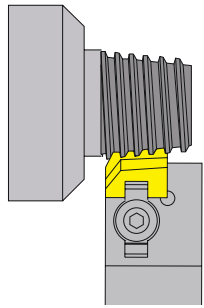

Inch Description	UPC No. 733101-		A	B	C	E	F	API Chaser Gage Insert	Shim Seat	Lock Screw	Chip Breaker	Clamp	Clamp Screw
	R.H.												
CLVOR-20 4T E	59003		1.25	1.25	7.00	1.25	.550	4 TOOTH**	CHSS-4TER	TS10-4	CB-4TER	HC-12	CS-126

*Accepts 3 and 4 tooth RD, NPT, and 3 tooth Buttress. **Accepts 4 tooth Buttress ONLY. For API Chaser inserts see pages D-50. For spare part see Page E-70.
 For API Jet-Stream™ Thru Coolant Threading Toolholders and Bars see Pages E-52-E-57

Threading & Grooving Spare Parts

Finger Clamp		Desc.	UPC No. 733101-	B	C	D	E	G	Thread	PKG.
	CL-5	90680	.280	.52	.350	.102	-	-	10-32	10
	CL-6	90681	.310	.58	.440	.187	.094	-	10-32	
	CL-7	90682	.310	.64	.310	.082	-	-	10-32	
	CL-9	90683	.430	.75	.660	.344	.125	-	5/16-24	
	CL-12	90684	.430	.88	.660	.344	.125	-	5/16-24	
	CL-19	90685	.310	.55	.310	.062	-	-	10-32	
	CL-20	90686	.375	.73	.380	.125	-	-	1/4-28	
	CL-24	90687	.491	1.0	.785	.453	.136	-	3/8-24	
	CL-30	90688	.430	1.0	.660	.344	.125	-	5/16-24	
	Negative Lock Pins		Desc.	UPC No. 733101-	Insert I.C.	Nominal Length	Thread	Hex Wrench Size	PKG.	
	NL-23	90472	.250	.328	8-32	1/16	10			
	NL-33	90473	.375	.344	10-32	5/64				
	NL-33L	90474	.375	.406	10-32	5/64				
	NL-34	90475	.375	.453	10-32	5/64				
	NL-34L	90476	.375	.516	10-32	5/64				
	NL-43	90477	.500	.420	10-32	5/64				
	NL-44	90478	.500	.516	1/4-28	3/32				
	NL-46	90479	.500	.672	1/4-28	3/32				
	NL-46L	90480	.500	.730	1/4-28	3/32				
	NL-56	90481	.625	.703	5/16-24	1/8				
	NL-57	90482	.625	.810	5/16-24	1/8				
	NL-58	90483	.625	.859	5/16-24	1/8				
	NL-58L	90484	.625	.890	5/16-24	1/8				
	NL-66	90485	.750	.703	3/8-24	9/64				
	NL-66L	90486	.750	.828	3/8-24	9/64				
NL-68	90487	.750	.859	3/8-24	9/64					
NL-68L	90488	.750	.953	3/8-24	9/64					
NL-808	90489	1.00	.940	7-16-20	5/32					
NL-810	90490	1.00	1.17	7-16-20	5/32					

Torx Keys		Desc.	UPC No. 733101-	Desc.	UPC No. 733101-
	T-6	92001		T-15	92006
	T-7	92002		T-20	92007
	T-8	92003		T-25	92008
	T-9	92004		T-30	92009
	T-10	92005			

Finger Clamp Screws		Desc.	UPC No. 733101-	A	B	C	Thread Size	Hex Wrench Size	PKG.
	XNS-26	90900	0.750	.31	.31	8-32	5/64	10	
	XNS-35	90901	0.625	.22	.22	10-32	3/32		
	XNS-36	90902	0.750	.25	.25	10-32	3/32		
	XNS-37	90903	0.840	.31	.31	10-32	3/32		
	XNS-38	90904	1.000	.37	.37	10-32	3/32		
	XNS-46	90905	0.750	.31	.31	1/4-28	1/8		
	XNS-47	90906	0.875	.28	.28	1/4-28	1/8		
	XNS-48	90907	1.000	.37	.37	1/4-28	1/8		
	XNS-58	90910	1.000	.50	.28	5/16-24	5/32		
	XNS-59	90911	1.125	.47	.41	5/16-24	5/32		
	XNS-510	90908	1.250	.50	.50	5/16-24	5/32		
	XNS-512	90909	1.500	.62	.62	5/16-24	5/32		
	XNS-610	90912	1.250	.50	.50	3/8-24	3/16		

Threading OnEdge Insert Torx Screw		Desc.	UPC No. 733101-	I.C.	Torx key	PKG.
	GTS-1M	90964		.375	T-10	10
	GTS-2	90966		.500	T-20	
	GTS-3	90967		.625	T-20	
	GTS-4	90968		.720	T-30	
Boring Insert Torx Screw		Desc.	UPC No. 733101-	I.C.	Torx key	PKG.
	TS-06	91306		.1562	T-6	10
	TS-08	91308		.1875	T-6	
	TS-25-45-6M2	90972		.2500	T-7	
	TS-35.6-9M1	90973		.3750	T-10	
	TS-35.6-14M1	91303		.3750	T-10	
	TS-45.75-15M1	91319		.5000	T-20	
	TS-1032-5M1	90960		.5000	T-20	
TS-5.8-22M1	91302		.6250	T-25		

Bridge Clamp Screws		Desc.	UPC No. 733101-	length	Thread	Hex Wrench Size	PKG.
	CS-126	90925	.860	1/4-28	5/32	10	
	CS-96	90923	.840	10-32	1/8		

Bridge Clamp Screw Clip		Desc.	UPC No. 733101-	length	PKG.
	CLP-12	90930	.422	10	
	CLP-9	90928	.312		

Chaser Bridge Clamp		Desc.	UPC No. 733101-	L	D	H	PKG.
	HC-12	90919	.812	.500	.266	10	
	HC-9	90917	.625	.375	.203		

Chaser Shim Seat		Desc.	UPC No. 733101-	L	D	T	PKG.
	CHSS-3TER	88581	.630	.492	.125	10	
	CHSS-4TER	88582	.870	.510	.187		
	CHSS-3.4TIR	88583	.620	.510	.187		
	CHSS-7.0TIR	88584	1.000	.488	.125		

Chaser Lock Screw		Desc.	UPC No. 733101-	PKG.
	TS10-4	90957		10

Chaser Chip Breaker		Desc.	UPC No. 733101-	L	D	T	PKG.
	CHCB-3TER	88576	.630	.460	.125	10	
	CHCB-4TER	88577	.800	.500	.125		
	CHCB-7TER	88581	1.00	.510	.125		
	CHCB-3TIR	88578	.630	.460	.125		
	CHCB-4TIR	88579	.800	.500	.125		
	CHCB-7TIR	88580	1.20	.510	.125		

V-Bottom Clamp		Desc.	UPC No. 733101-	PKG.
	JSLC-HPV84-5	63880		1

V-Bottom Clamp Screw		Desc.	UPC No. 733101-	PKG.
	CS-M0616	63885		10